



A Joint Venture of Andhra Pradesh Gas Distribution Corporation Ltd. and
Hindustan Petroleum Corporation Ltd

VOLUME II OF II

OPEN DOMESTIC COMPETITIVE BIDDING

BID DOCUMENT

FOR

**COMPOSITE WORKS IN VARIOUS CNG STATIONS AT
EAST & WEST GODAVARI DISTRICTS OF ANDHRA PRADESH**

(TENDER NO: GGPL/KKD/C&P/CW/2523/VS)

TENDER NO: GGPL/KKD/C&P/CW/2523/VS



VOLUME – II OF II

TECHNICAL SPECIFICATIONS

CONTENTS

LIST OF SPECIFICATION/STANDARDS

- PART-I : Civil, Structural and Architectural Work**
- PART-II : Electrical and illumination Work**
- PART-III : Mechanical Work**
- PART-IV : Instrumentation Work**
- PART- V : Typical CNG station/De-compression unit layout Drawings**

TENDER NO: GGPL/KKD/C&P/CW/2523/VS



PART-I

TECHNICAL SPECIFICATION FOR CIVIL, STRUCTURAL AND ARCHITECTURAL WORK

1. CIVIL, STRUCTURAL AND ARCHITECTURAL WORKS

1.1. GENERAL

The scope of work to be performed under this contract shall include complete civil, architectural and steel structural works as per plans, equipment layout, drawings & technical specifications for the 'CNG Stations & De-compression unit installations.

1.2. SCOPE OF SUPPLY

Contractor shall procure & supply to site all the materials including cement, reinforcing steel, steel sections, plates, pipes, MS Y Angle Posts, Concertina coil, RBT fencing wire, Chain link fencing, chequered plate, Colour coated steel sheets, False ceiling, mesh and other accessories, other masonry materials, bitumen/asphalt, admixtures & bonding agents, sealants, kerb stones, paver block, sand, boulder, etc., and any other construction material / item required to complete the civil & structural works.

All costs towards testing/inspection of materials/goods shall be borne by the Contractor.

1.3. SITE WORK

Complete construction work including supply of labour, construction materials, construction equipment, survey, tools & tackles, dismantling & modification / strengthening, supervision, testing etc. required to complete all the structures, foundations, roads, drains, pavements, finishes, supply, fabrication, erection of steel structures, Canopy, hoarding, Loading unloading platform, LCV Platform, cat ladder, welded wire mesh fencing and gates etc, painting, including site grading/earthwork in cutting & filling etc. as specified and required to complete the civil & road works in all respect.

All enabling works e.g. construction water tank, casting/fabrication yard, electricity, site stores & office, safety and security measures, coordination with other contractors working at site etc. shall be Contractor's responsibility.

1.4. SCOPE OF WORK

The scope of work shall be broadly, but not limited to, the following:

- a. Site grading of the plot by removing 150 mm top soil, , stacking it properly and reusing it for planting purpose, including plot development by filling good quality earth as required.
- b. Earth filling in embankments for external roads wherever required with providing of RCC Culverts/ Pipe Culvert.
- c. Clearing the site, removal of bushes and trees etc as per site requirement.
- d. Construction of a 3 m high boundary wall with brick masonry, PCC Coping, MS Y Angle Posts and Concertina coil with RBT fencing etc as per drawing.

-
- e. RCC cable trenches: complete civil works for cable trench including providing inserts, conduits (GI, PVC or HDPE etc.) and PVC coated MS Chequered cover plate / Pre cast concrete covers as per requirement.
 - f. Construction of single and double S.S.tube trench as per drawing.
 - g. Construction of compressor foundation as per drawing.
 - h. Construction of Green belt etc as per drawing.
 - i. Construction of Dispenser foundation, canopy foundation etc. as per relevant drawings.
 - j. Construction of fore court, approach roads etc. as per drawing.
 - k. Construction of cable pit, drain pits etc as per requirement.
 - l. Construction of Septic Tank along with Soak Pit and connections.
 - m. Storm water drainage system in RCC/brick drains with complete civil works as per requirement.
 - n. Laying of Hume pipes for drainage as per drawing and requirement of site.
 - o. Construction of Utility/Office building - Control room, Office room, Store Room, UPS and Battery Room, Electrical Room etc as per relevant architectural drawings.
 - p. Construction of Bore well as per supplier specification and direction of Engineer in charge.
 - q. 80 mm thick PCC paver block over sand cushion over ground/on a PCC base (Grade M-10) at locations as specified.
 - r. Laying PCC kerb stones 125mm x 300 mm over 75 thk PCC base (Grade M- 10) as specified.
 - s. Grouting of all base plates/frames of equipment foundations and structural bases.
 - t. Providing of all inserts, conduits, pre-cast covers, fixing of free issue items into permanent works etc.
 - u. Providing of approved quality sand for back filling as per requirement.
 - v. Clearing all construction debris and handing over completed work site.
 - w. Any other work not specifically mentioned but required to make the station functional.
 - x. Making as-built details/drawings on one set of construction drawings and return to owner.

2. PREAMBLE TO SCHEDULE OF RATES

The Preamble to Schedule of Items is an integral part of the schedule of quantities and rates and this is to be considered incorporated into the description of items themselves. The Contractor's rate for any item of work in the schedule of item shall, unless stated otherwise be held to include the cost of all materials including wastage, conveyance and delivery, unloading, storing, fabrication, all consumable materials, like MS bolts, washer, electrodes, putty, gases, splices paints, tools and plants, power fuel, consumables, all taxes, royalties, other revenue expenses, temporary facilities like roads etc.

The item shall include all the safety provisions listed below:

-
- The site should be cordoned off on all sides by way of 3 Mt. High corrugated GI sheet fixed on metal pipes/angles, leaving space for only a Gate. This fencing should be fixed such that it is not possible for anyone to enter the site from any other location other than the Gate.
 - The gate should be made in metal with metal sheet cladding. A guard restricting entry of all unauthorized person/material on site should man the gate. The guard shall also maintain a register of all persons visiting site.
 - All persons including all labor, supervisors, visitors etc. on site must wear hand gloves, helmet and safety shoes. The responsibility of this shall rest with the main contractor.
 - All workmen while working on height shall wear safety helmets.
 - All workmen such as welders/ fitters etc. shall wear protective gloves, protective glasses etc. and as per the requirement and demands of the trade.
 - All excavated pits/holes shall be cordoned off with red tape with warning notice.
 - All inflammable material shall be kept in non-inflammable containers that are fixed with screwed on caps at all times. The containers should be marked with danger sign and the name of the material shall be marked on the outside. There should be at least one person who should be responsible for the safe custody of these materials.
 - All areas of work shall have appropriate safety signage depending on the nature of work, prominently displayed to prevent any mishap, particularly signs in fluorescent paint for night vision. These signs should be visible from a reasonable distance for a vehicular traffic at designated speed limits for a given road/ location. All necessary city traffic rules and signage specifications shall be observed with strict adherence.
 - All gadgets must have required safety devices in working conditions as per the manufacturers' recommendations and the law of the country.
 - All the persons on site must be insured against injury and death due to accidents.

-
- The contractor shall not use the site for any activity other than what it is authorised for.
 - Children below the age of 16 shall not be allowed to work on site. The contractor shall prepare a secured crèche adjacent to the site, for the children of labor working on site and there shall be at least one person dedicated to look after the safety and other needs of these children at all time.
 - All persons working at site shall be physically and mentally fit. The contractor shall ensure that no illegal activity takes place on site and that no person with doubtful past shall be engaged on site.
 - The contractor shall be responsible for the safety of all persons at site.
 - Consumption of liquor and smoking shall not be permitted on the site.
 - The site shall be illuminated at night when there is work in progress.
 - The contractor shall maintain a First-aid box at site to take care of any minor injury.
 - The storing of all inflammable/explosive material shall be done as per the laws of the country and best common practice.
 - All temporary electrical connections shall be done with the help of insulated connectors to prevent any sparking etc.
 - Contractor shall keep the Owner and Consultant completely indemnified by ensuring a completely safe working, keeping a third party insurance cover on site.

2.1. SITE CLEARANCE

Complete works for the site clearing so that the site is suitable for construction activity. Brief description of major items shall be as follows:

- a. Dismantling of all existing structures in brick masonry/stone masonry/ RCC /PCC, road, fence, sheds, cladding, sheets etc. so that the site becomes suitable for construction activity.
- b. Disposal of all material to be cleared from the site to any authorised disposal site/ storage yard.

- c. Removal of trees up to and above 30cm girth as per respective SOR items.
- d. Provide all assistance/co-ordination/liaison between any and all government/ semi government agencies connected with the scope mentioned and also with the body owning/maintaining the access road to the site.

Note:

1. Site Clearance including removal of vegetation shall be measured in m^2 .
2. Demolition of RCC/PCC/Brick Masonry and road will be paid in M^3 .
3. Trees shall be counted in numbers for more than 30 cm girth.

2.2. EARTHWORK IN SITE GRADING, EXCAVATION & BACKFILLING FOR PLOT DEVELOPMENT, ETC.

Brief description of major items shall be as follows:

- a. Taking pre-work and finished levels.
- b. Stripping and grubbing the top soil of 150 mm and preparation of sub-grade.
- c. Excavating excess soil and soft rock if any to develop the plot.
- d. Dewatering of excessive water.
- e. Backfilling with serviceable earth in layers of 150 mm thickness in controlled way.
- f. Watering and compaction up to '95% or as per direction of Engineer in charge of its MDD with PM Chanical means.
- g. Disposal of unserviceable and surplus earth/rock to a suitable dumping ground to any lead.
- h. Actual work shall be carried out as per certified construction drawings to be issued to successful tenderer.

Note:

- i. For all these items only net excavated quantity in CuM shall be measured for payment.
- ii. No separate payment for excavation for foundation / sewerage forecourt or Road work/other items where earthwork is included (since cost of earthwork is included in respective items).
- iii. Measurement for rock breaking shall be done by stacking. 35% of stack measurement shall be deducted as voids.

Earthwork shall be done as per approved detailed construction drawings to be issued to the successful tenderer. Offer to be prepared by the tenderer based on the enclosed drawings and on lump sum unit rate (per M^3).

2.3. EARTH WORK IN FILLING

Complete earthwork in filling with borrowed earth is included in the scope. Brief description of major items shall be as follows:

- a. Taking pre-work and finished levels.
- b. De-watering of excessive water.
- c. Strutting and shoring to retain the earth.
- d. Borrowing of approved quality good earth from any lead.
- e. Filling in layers of 150 mm.
- f. Watering and compaction up to '95% or as per direction of Engineer in charge' of its MDD with Mechanical means.

Note:

Payment for item earthwork in filling shall be paid for compacted net volume of filling after deductions of foundations, culverts, etc

2.4. SAND FILLING AND STONE SOLING

Complete works in filling is included in the scope. Brief description of major items shall be as follows:

- a. Taking pre-work and finished levels
- b. Borrowing of approved quality sand/stone from any lead.
- c. Filling in layers of 150 mm.
- d. Providing and laying stone ballast 40-63 mm size in layers of 150 mm with spreading blinding material like murum, bajri, stone grit and compaction with road roller etc. complete the surface as per specifications including cost of material.
- e. Watering and compaction by 10 T rollers.

Note:

- i. Payments to be done on completed work profiles by considering the plan dimensions only. Sand filling and Stone soling shall be done as per approved detailed construction drawings to be issued to the successful tenderer. Offer to be prepared by the tenderer based on the enclosed drawings and on lump sum unit rate (per M³).

2.5. PCC WORK

Providing and laying PCC M 7.5 (1:4:8) / M 10 (1:3:6) / M15 (1:2:4) in all positions, in foundations, substructure, superstructure and under floor, etc. (at locations where the same is not included in respective SOR items, eg RCC in Substructure, Brick work, Concrete pavement etc.) complete in all respects as per scope of work, detailed construction drawings, technical

specifications and direction of Engineer-in-charge.

Following works shall be inclusive in the rate of PCC item:

- a. Earth Work in excavation including back filling (including disposal of surplus earth).
- b. Preparation of bed including cleaning, levelling, compacting/tamping of surface and providing support from bottom and sides.
- c. Providing shuttering and strutting of all types (If necessary).
- d. Providing inserts, pockets, recesses, holdfast etc.
- e. Curing, rendering, finishes to match with adjoining surfaces etc.

Note:

- i. For all these items only net PCC concrete quantity in M^3 shall be measured for payment. PCC below brick work and RCC works is included in the respective item.

The construction of PCC work shall be done as per approved detailed construction drawings to be issued to the successful tenderer. Offer to be prepared by the tenderer based on the enclosed typical drawings and on lump sum unit rate (per M^3) of PCC work done.

2.6. REINFORCED CEMENT CONCRETE - SUB STRUCTURE

Brief description of major items shall be as follows:

- a. Earth Work in excavation including back filling using serviceable surplus/ borrow material, disposal of surplus earth (wherever required), including bailing out water (where ever required), shoring / strutting etc.
- b. 100 mm thk. PCC M-10 in mud mat.
- c. Providing shuttering and strutting of all types.
- d. RCC M25 as per drg. & specification including supply of cement, coarse aggregate, fine aggregate and placement of concrete at all levels and depths, all inclusive & testing of concrete and other materials.
- e. Providing and fixing of all anchor bolt and nuts into permanent works etc.
- f. Providing and fixing of all inserts, conduits, precast covers into permanent works etc.
- g. Provision of chequered plates, gratings into permanent works as per SOR item of Structural works.
- h. Grouting of all base plates/frames of equipment foundations as per requirement.
- i. Application of two coats of hot bitumen on surfaces in contact with soil.

Note:

- i. For all these items only net RCC quantity in M^3 shall be measured for payment.
- ii. Earth work with borrowed earth shall be paid vide respective SOR item.
- iii. Anchor bolts and nuts shall be paid vide respective SOR item.

- iv. Grouting with non shrinkable compound shall be paid vide respective SOR item

2.7. REINFORCED CEMENT CONCRETE - SUPER STRUCTURE

Brief description of major items shall be as follows:

- a. Providing shuttering and strutting of all types
- b. RCC M25 as per drg. & specification including supply of cement, coarse aggregate, fine aggregate and placement of concrete at all levels, all inclusive & testing of concrete and other materials.
- c. Grouting of all base plates/frames of equipment foundations and structural bases as per requirement.
- d. Providing and fixing of all anchor bolt and nuts into permanent works etc.
- e. Providing and fixing of all inserts, conduits, precast covers into permanent works etc.
- f. Provision of chequered plates, gratings into permanent works as per SOR item of Structural works.

Note:

- i. For all these items only net RCC quantity in M³ shall be measured for payment. The RCC quantity of building superstructure is included in the Building Works item.
- ii. Anchor bolts and nuts shall be paid vide respective SOR item.
- iii. Grouting with non shrinkable compound shall be paid vide respective SOR item.

2.8. REINFORCEMENT STEEL

- a. Supplying , fabricating and fixing in position HYSD steel reinforcements / TMT grade Fe-415/Fe- 500 confirming to IS 1786-1985 at all levels and positions.
- b. Straightening, cutting, bending, cranking, binding, welding, provision of necessary chairs and spacers for reinforcement bars as per drawing and construction requirements.
- c. Preparation of bar bending schedule drawings and getting the same approved by site engineers as directed by EIC.

Note:

- i. Rate to include cost of all labour, tools, tackles, equipment, hire charges, supply of all materials such as steel reinforcement, binding wire and other minor construction materials, testing etc. all bye works and sundry works complete in all respects.
- ii. Chairs, laps, spacers, wastage etc. shall be to contractor's account.
- iii. Only net reinforcement bars as per approved BBS / as laid at site shall be considered for payment.

2.9. BRICK WORK IN SUB STRUCTURE / CC BLOCKS (200mm thick)

Complete works in brick masonry sub structure is included in the scope. Brief description of major civil items shall be as follows:

- a. Earthwork in excavation including back filling using serviceable surplus material or approved borrow material and transportation of excess earth beyond plot limits. Preparation of sub-base including de-watering and compaction.
- b. CC block work for sub structure and super structure with not less than M7.5 grade, minimum compressive strength 75 kg/sqcm in 1:4 cement sand mortar (in coarse sand.)
- c. Brick work for SS tubing trench with not less than M-5 grade bricks/ minimum comp. Strength of 50 kg/cm² in 1:6 cement sand mortar (in coarse sand).
- d. 150 mm thk. PCC (M-10) in levelling course.
- e. DPC 50 mm with cement concrete M-15 (1:2:4) as per requirement with water proofing compound and application of bituminous paint
- f. 15 mm thk. plastering in CM (1:4) (in coarse sand) on exposed brick surfaces.
- g. Application of two coats of hot bitumen on surfaces in contact with soil.
- h. Applying Lime wash / Cement based paint / Weather proof paint on plastered faces in sub structure as specified in drawings.
- i. Making weep holes of 150 mm x 150 mm with stone filter pack at 1.0 m intervals in both the directions.

Note:

- i. Only net brick masonry quantity excluding plaster thickness shall be measured in M³ for payment purpose.
- ii. Earth work in backfilling with borrowed earth shall be paid vide respective SOR item. The construction of brick work shall be done as per detailed construction drawings to be issued to the successful tenderer. Offer to be prepared by the tenderer based on work described above.

2.10. BRICK WORK IN SUPER STRUCTURE /CC BLOCKS

Complete works in brick masonry super structure is included in the scope. Brief description of major civil items shall be as follows:

- a. CC block work for sub structure and superstructure with not less than M7.5 grade , minimum compressive strength 75 kg/scm in 1:4 cement sand mortar (in coarse sand).
- b. Brick work for ss tubing trench with not less than M-5 grade bricks/minimum comp. strength of 50 kg/scm in 1:6 cement sand mortar (in coarse sand).
- c. 15 mm thk plastering in CM (1:4) (in course sand) on exposed brick surfaces.

- d. All niches, offsets, pockets etc shall be considered part of the work.
- e. Providing shuttering / supports etc. as per requirement.
- f. Applying Lime wash / Cement based paint / Weather proof paint / oil bound distemper /Acrylic paint on plastered faces in super structure as specified in drawings.

Note:

- i. Only net brick masonry quantity excluding plaster thickness shall be measured for payment purpose.

The construction of brick work shall be done as per detailed construction drawings to be issued to the successful tenderer. Offer to be prepared by the tenderer based on work described above and payment will be made on rate (per M³) of brickwork done.

2.11. BRICK MASONRY/CC BLOCKS(200mm thick) BOUNDARY WALL IN SUPER STRUCTURE

Complete works of brick masonry wall in superstructure including RCC, PCC, DPC, Coping with MS Y Angle Posts and Concertina coil with RBT fencing etc as per drawing. Brief description of major civil items shall be as follows:

- a. CC block work for sub structure and superstructure with not less than M7.5 grad, minimum compressive strength 75 kg/scm in 1:4 cement sand mortar (in coarse sand).
- b. RCC M-25 Including steel reinforcement for coping.
- c. Drip course 25 mm wide over coping.
- d. 15 mm thk plastering in CM (1:4) (in coarse sand) on exposed brick surfaces.
- e. Painting of exposed wall surface with three coats of Acrylic emulsion paint as approved by Engineer-in-charge.
- f. Expansion joints shall be provided as per drawing.
- g. Approx 600 mm High MS Y angle Posts including painting as per specification with 9 straight lengths of RBT fence with 2.6 mm dia spring core wire and short barbs of 11 mm width and circular Concertina coil of 600 mm dia with 50 turns per coil expandable between 6-8m and approx. weight of 8 Kg per coil.

Note:

Only net Boundary wall length including Pillars shall be measured in 'M' for payment purpose. The construction of masonry boundary wall shall be done as per detailed construction drawings to be issued to the successful tenderer.

2.12. SOAK PIT AND SEPTIC TANK

Complete works for the making and proper functioning of soak pit and septic tank is included in the scope:

Brief description of major items shall be as follows:

- a. Earth work in excavation, back filling, and disposal of surplus earth. b. P.C.C. M-15 (1:2:4).
- c. Brick work of M-5 grade in 1:5 cement mortar.

- d. Plaster 12 mm thick 1:3 in coarse sand, finished with floating coat of neat cement inside and rough plaster outside.
- e. Brick bat filling in soak pit.
- f. Honey comb brick work in soak pit.
- g. RCC M-25 including reinforcement, shuttering etc in top slab.
- h. Making all types of connections for sewerage collection and disposal.
- i. Providing and fixing cast iron vent pipe up to required height as per drawing.

Note:

Soak pit and septic tank shall be provided inclusive of all related works, as per approved detailed drawings to be issued to the successful tenderer. Offer to be prepared by the tenderer based on the enclosed drawings and on lump sum unit rate (per installation).

2.13. PAVER BLOCK (80 mm THK) PAVEMENTS IN SPECIFIED AREAS

Brief description of major works to be considered in this item is as follows:

- a. Earthwork in excavation including back filling upto required level (including using borrow earth and disposal of surplus earth).
- b. Filling in layers of 150 mm thickness in controlled way.
- c. Watering and compaction up to 95% of modified dry proctor density of soil with Mechanical means.
- d. Providing and laying / fixing 80 mm thick M-30 Paver Blocks over 75 mm thk. sand cushion over well compacted sub grade / PCC as specified.
- e. Filling joints between the blocks with fine River sand.
- f. Making slopes, finishing edges, leaving pockets for pedestals & sleepers.
- g. Actual work shall be carried out as per certified construction drawings to be issued to successful tenderer.

Note:

- i. Complete civil works for Paver Block Pavement including, earth work in excavation, preparation of base i.e., compacted sub grade, 100mm thk. sand filling and compaction, etc. are included in the works & payment shall be made under Paver Block Pavement item. Only net laid quantity shall be considered for payment purpose.
- ii. PCC under the Paver Block Pavement wherever specified shall be paid under separate PCC item.

2.14. RCC KERB STONE IN SPECIFIED AREAS

Brief description of major works to be considered in this item is as follows:

- a. Earth Work in excavation including back filling up to required level (including using borrow earth and disposal of surplus earth).
- b. Supplying and fixing M-25 Kerb Stone Blocks 125 mm x 300 mm over 75 mm thk. PCC - M 10 grade.

- c. Filling joints between the blocks with cement mortar (1:3) (in coarse sand).
- d. Actual work shall be carried out as per certified construction drawings to be issued to successful tenderer.

Note:

Complete civil works for Kerb Stone including, earth work in excavation, preparation of base i.e., compacted sub grade, 75 mm thk. PCC, etc. are included in the works & payment shall be made in RM. under Kerb Stone item.

2.15. BUILDING WORKS

Complete civil and architectural works for the buildings is included in the scope:

Utility/Office building - Control room, Office room, Store Room, UPS and Battery Room, Electrical Room etc

Brief description of major civil and architectural under the item is as follows:

- i. Site grading of the plot by removing 150 mm top soil stacking it properly and reusing it for planting purpose, including plot development by filling good quality earth as required in the new areas to be developed.
- ii. The building shall be RCC framed structure with cladding and partitions of masonry walls.
- iii. Construction of all sub-structures and superstructures.
- iv. Anti-termite treatment to be applied to the building foundations, plinth and under flooring inside the building and under Apron.
- v. DPC 40 mm with cement concrete 1:2:4 as per requirement with water proofing compound of CICO/ PIDILITE/ SIKA and application of bituminous paint.
- vi. All underground concrete/ masonry structure in contact with earth shall be given two coats of hot bitumen application.
- vii. All structural concrete for RCC elements shall have a minimum strength of 25 MPa at 28 days. Grade of concrete in R.C.C. works shall be M-25.
- viii. Masonry shall be in cement mortar 1:4 (in coarse sand) and with CC blocks of strength not less than 7.5 MPa.
- ix. Plastering on masonry structures shall be of thickness 15 mm on either faces, and 6 mm on concrete faces. The cement mortar shall not be leaner than 1:4 in coarse sand.
- x. All chhajja/ canopy projections shall have drip mould grooves underneath all along periphery.
- xi. Entrance door/door for office/officer, control room of the building shall be anodized aluminium

/powder coated of approved shade fully / partially glazed , 6 mm thick float glass(ASAHI/MODI/TUFF) panes fixed with necessary gaskets and aluminium beading strip or panelled (double sided) with pre laminated board, double leaf / single leaf doors with floor springs. All windows/ ventilators shall be aluminum glazed min. 6mm thick glass (ASAHI/MODI/TUFF) with anodized aluminum/powder coated hardware with aluminum grill. The windows / ventilators shall be partially/ fully fixed or openable, casement or sliding windows as per requirement and drawing. The fixtures like handles, stoppers ,stays, etc., shall also be anodized aluminium/powder coated and shall be of approved make. All aluminium sections shall be of standard make like Jindal, Hindalco or approved equivalent. Aluminium alloy used in the manufacture of extruded sections shall correspond to IS Designation HE 9 WP of IS 733. Hollow aluminium alloy sections used shall conform to IS Designation HV9 WP of IS 1285. The sections shall be polished and anodized with approved colour. The average thickness of anodic coating shall not be less than 20 microns as per IS: 1868-1982. All work shall be fitted and shop assembled to a first job, and ready for erection. EDPM performed profiles shall be used for inserting into extruded pockets of sections. Glazing beads shall also be of EDPM performed profiles to hold the glass in frame under pressure. Non metallic setting blocks shall be used to centralize the glass in frame. All work shall be adequately braced and reinforced as necessary for strength and rigidity. Stainless steel ball bearings, housed in nylon type nylon rollers, shall be used. All Mechanical connections shall be sealed with silicon sealant. Around all windows, approved quality sealants shall be run down to make sure of total weather/water sealing.

- xii. Windows shall have aluminium grills (Diamond Window Grill from Decogrill or approved equivalent).
- xiii. Toilet doors shall be of high grade PVC (Sintex or approved equivalent) with suitable frames.
- xiv. Flush doors, wherever required, shall have shutters conforming to IS:2202 (Part I) decorative type, core of block board construction with frame of 1st classhard wood and well matched teak 3 ply veneering with vertical grains or cross bands and face veneers on both faces of shutters, 35mm thick including IS marked stainless steel butt hinges with necessary screws. Frames shall be pressed steel single/double rebate door frames conforming to IS: 4351 manufactured from commercial mild steel sheet of 1.25 mm thickness including hinges jamb, lock jamb, bead, etc.
- xv. Inside walls and ceilings of rooms/ buildings shall be finished with acrylic washable distemper on Birla Putty or JK Putty and outside with weather resistant paint “Weather shield” of ICI or “Apex Ultima” of Asian Paints of approved color on Birla Putty or JK Putty.

Rain water pipes of pvc shall be provided. Only approved make shall be used. RCC channels for cables, pipe trenches etc. shall have provision of MS chequered plate / PVC coated MS Chequered cover plate/ electrical room (as per requirement) and payment for chequered plates shall be paid as per SOR item of Structural works.

-
- xvi. Inserts shall be provided to suit the technological requirements.
- xvii. All exposed flat roofs shall be treated with “Aquashield APP” of STP or “Davco Armour shield” of Chryso over a layer of screed concrete as per suppliers specification.
- xviii. If sloping roof is provided as per design drawing, the same shall be finished with decorative plaster.
- xix. Grade slab in flooring shall be of 150mm thick RCC of M-25 grade, 100 thick P.C.C. (M-10) over a compacted sand layer of 250mm on well-prepared sub base.
- xx. Flooring & skirting in SCADA room, Office/ Control room, Verandah shall be provided with 10mm to 12 mm thick vitrified ceramic tiles (600 x 600) mm of make Asian/Kajaria/Johnson / Somany etc.) on a bed of 20mm thick cement mortar of 1:4 proportion be provided. Skirting height shall be 150mm. Flooring and skirting in Electrical room shall be heavy duty vitrified tiles (600X600) mm.
- Flooring and Dado in UPS / Battery room shall be provided with Acid proof tiles Pavigres of Kajaria (size 300X300mm).
The height of dado in UPS/Battery room shall be 2400 mm with respect to finished floor level. Eye/Face wash, model no.7001 pedestal mounted from Tobit Engineers shall be provided in UPS/Battery room.
- xxi. Flooring & dado of Fire Protection room, store shall be of polished Kota stone.
- xxii. All M.S. doors/window & louvered door for electrical room etc., wooden doors & leafs shall be painted with 3 coats of synthetic enamel paint on pink/zinc chromate primer.
- xxiii. All finishes, painting, locking arrangement, etc. any other works not specifically mentioned but required for completion and handing over of premises, complete in all respects.
- xxiv. Apron 0.90M/1.0 m wide (as per drawing) of PCC M-10 grade and peripheral Storm water drains in Brick around building (as per requirements).
- xxv. Electrical work including lighting inside the building and outside shall be under the scope of this contract. The quantity of fixture etc. shall be covered under Electrical SOR for the terminal.
- xxvi. Mineral fibre false ceiling of “Armstrong” or equivalent make of approved pattern shall be provided in Scada, Telecom and Electrical Rooms, office room, engineers room, discussion room etc. as mentioned in working drawings. The tiles shall be beveled/ tegular tiles of size (600 x 600 x19) mm with 95% humidity resistance, light reflectance >80%, 0.7 NRC, thermal conductivity $k=0.052- 0.057$ w/m0c, class O/class1(BS 476 classification) fire performance or equivalent .Tiles to be laid on 24XL-hot dipped galvanised steel suspension system having rotary stitching on the main runner, 1200mm & 600mm cross tees making regular cut out for light fittings, fire sprinklers, etc., fixing & finishing. Ceiling to be

finished neat and complete so that no irregularities are visible after finish, including providing caps to the cut outs after fitting the fire sprinkler nozzles.

- xxvii. One or more 1000 liter overhead Sintex tank with necessary GI incoming and outgoing pipes and fittings along with 0.5 HP pump for pumping water shall be provided for supplying water in toilets / other areas.
- xxviii. Toilets and pantry fixtures shall be provided as follows: EWC no. 20024 of Hindware, Flat back urinal no. 60002 of Hindware, Pedestal type Wash Basin no. 10010 of Hindware, Stainless steel Sink of size 410X410 of Nirali, unless mentioned otherwise in architectural drawings.
- xxix. Toilets to have first quality chromium plated fittings - taps, faucets, stopcocks, etc. of Jagaur/ Parryware/ Cera, liquid soap dispenser, towel rail, deodorant holder, coat hook, china recessed toilet paper holder, anti cockroach chilly trap, etc.
- xxx. Toilets and pantry shall have anti-skid ceramic tiles flooring and ceramic tiles dado upto +1500 mm height from FFL.
- xxxi. Cutouts for exhaust fans to be made at beam bottom in Battery Room and Electrical Room in required numbers.
- xxxii. M.S. Cat ladder to be provided for roof approach.
- xxxiii. M.S. railing, wherever required, shall consist of handrail of 63X32X3.2 mm M.S. hollow section, 16X16 mm M.S. sq. bar balusters @ 250mm c/c and 2 nos. 25X6 mm M.S. plate running horizontally at equal distances.
- xxxiv. Water supply piping with GI pipe complete with all fittings and jointing, pipe work, bronze valves with overhead tanks with high pressure ball cock, level indicator, level control and all its connections and platform, anti-mosquito over flow grating etc.
- xxxv.** A backlit signage hoarding in approved design including GODAVARI GAS logo of 5.0m x 1.0m prepared in aluminum framework with flexible sub strata and approved colored translucent vinyl to be provided on rooftop.(refer point no.- 2.25) (for payment refer separate SOR item).
- xxxvi. G.I. conduit to be fixed in concrete as per detail drawing shall be supplied and fixed in position.
- xxxvii. Clearing all construction debris and handing over completed work site .
- xxxviii. Making as-built details on one set of construction drawings and return to Owner.
- xxxix. Any other item not covered above but required for proper functioning of the building.

Note:

1. The construction of the building shall be done as per detailed construction drawings to be issued to the successful tenderer. Offer can be prepared by the tenderers based on the enclosed architectural and standard drawings and on lump sum unit rate (per sqm) for complete building work.
2. The payment for completed works shall be made as follows:
 - a. For superstructure all items (above Plinth Beam Level) as listed above shall be payable as per enclosed drawing No.PMC/05/11/STD/CNG/001.
 - b. Centerline measurement for building shall be considered for payment purpose.
 - c. For substructure e.g. foundations, plinth beam etc. and other items such as apron, peripheral drains, steps etc. respective SOR items shall be payable.
3. For electrical wiring, illumination and fixtures refer relevant parts of specification for Electrical Works. All Electrical works shall be paid under respective Electrical Items. However, all required civil works for electrical, instrumentation/ are in contractor's civil scope of work.

2.16. RCC GRADE SLAB IN FORECOURT

Complete civil works and other finishes in the fore court are included in the scope. Brief description of major civil items shall be as follows:

- a. Stone soling (150 mm thick) compacted with road roller and river sand filling in voids.
- b. 100 mm thick PCC M-10 (1:3:6).
- c. Laying of all required conduit, cables, pipes etc. and fixing them securely to the reinforcement bars (payable under separate item).
- d. RCC M25 (to be procured from batching plant/site prepared mix) 150 mm thick laid to slope including reinforcement and inserts, PVC sleeves, expansion joints and brush finish.
- e. Providing & laying 50 mm thick M25 screed over RCC floor with 4 mm dia and 75 X75 mm wire mesh (payable under separate item).
- f. Applications of non-metallic compounds, as per manufacturer's specifications to make the surface hard enough to bear abrasion, improve impermeability & resist weathering. The compound to be used shall be non-metallic hardener of Roff/ Fosroc/ STP/ CICO or equivalent.

lent (payable under separate item).

- g. Providing non-deteriorating board in expansion joints with polysulphide sealant (payable under separate item).
- h. Making of cable and steel tube trench with precast covers with lifting arrangement (payable under separate item but area of trench will be deducted from forecourt).
- i. Making dispenser islands including Granite/Vitrified tile top fixing and all its finishes (payable under separate item).
- j. Concrete paver blocks laid over PCC (payable under separate item).
- k. Fixing of concrete kerb stone blocks. Kerb stone blocks shall have niche with reflective material fixed in it (payable under separate item).
- l. Manhole, gully trap including precast covers.

Note:

- a. Only area of completed forecourt shall be measured for payment.
- b. The construction of fore court shall be done as per approved detailed construction drawings to be issued to the successful tenderer. Offer to be prepared by the tenderer based on the enclosed architectural drawings and on lump sum unit rate (per Sq.M) for complete work.

2.17. CULVERT

Complete works for the construction of culvert is included in the scope. Brief description of major civil work items shall be as follows:-

- a. Excavation of earth and back filling/disposal of the same.
- b. 350 mm thick PCC M-10 (1:3:6).
- c. CC Block of M-7.5 grade in 1:4 cement mortars as per design.
- d. 12 mm thick plaster in 1:3 on exposed brick surface.
- e. Laying of RCC pipe, joining the pipe lengths and encasing the same with 350 thick PCC M-15 (1:2:4).
- f. Diversion of existing drainage (if any) during construction and its restoration to original position after smooth joining of existing with new construction.

Culvert shall be made as per approved detailed construction drawings to be issued to the successful tenderer. Offers can be prepared by the tenderers based on the enclosed drawings

and on lump sum unit rate (per RM) of pipe dia. basis.

Note:

In case a R.C.C. box culvert is provided - the payment shall be made under R.C.C. composite rate.

2.18. EXTERNAL SEWERAGE & STORM WATER PIPING

Complete works for the installation and proper functioning of external sewerage and drainage is included in the scope.

Brief description of major items shall be as follows:

- a. Earth work in excavation and back filling.
- b. PCC M-15 (1:2:4).
- c. Laying pipes (SW, RCC pipe 150 / 300 mm dia).
- d. Connection to Municipal manhole.
- e. Restoration of site and clearing the debris.

External sewerage shall be provided inclusive of all related works, as per approved detailed drawings to be issued to the successful tenderer. Offer to be prepared by the tenderer based on the enclosed drawings and on lump sum unit rate (per RM) pipe laid.

2.19. ROADWORK

Complete works in making of road over well-compacted sub grade (CBR 4.0 - 5.0 in soaked condition) is included in the scope.

Brief description of major items shall be as follows:

- a. Preparation of sub grade including dressing to camber, making good all undulations, re-rolling with power road roller of 8 to 12 tons capacity etc.
- b. Supply, stacking, and laying two layers of 115 mm thick WBM with 90 mm to 45 mm graded stone aggregate stone screening and blending material including screening, sorting, spreading to template and consolidation with power roller of 8 to 10 tons capacity etc. using kankar, murum and red bajri etc.
- c. Supply, stacking and laying one layer of 75 mm thick base course WBM with 63 mm to 45 mm graded stone in the same fashion as above.

-
- d. Supply, stacking and laying one layer of 75 mm thick base course WBM with 53mm to 22.4 mm graded stone in the same fashion as above.
 - e. Providing and applying 75 mm thick Bitumen macadam with tack coat.
 - f. Providing and applying tack coat using hot straight run bitumen of grade 80/100 by spraying with Mechanically operated spray unit fitted with boiler, after cleaning and preparing the WBM surface @ 0.75 Kg/Sqmt.
 - g. Providing two layers of 25 mm thick premix carpet surfacing with 2.25 cum. and 1.12 cum. of stone chipping of 13.2 mm and 11.2 mm size respectively per 100 sqmt and 52 kg and 56 kg of hot bitumen per cum of stone chipping of 13.2 mm and 11.2 m size respectively including a tack coat with hot straight run bitumen including consolidation with road roller of 6 to 9 tons capacity etc. complete with paving asphalt 60/70 with no solvent.

Road making shall be done as per approved detailed construction drawings to be issued to the successful tenderer. Offer to be prepared by the tenderer based on the enclosed drawings and on lump sum unit rate (per SqM) of premix carpet surface laid.

2.20. PRE-CAST SLAB

Brief description of main items shall be as follows:

Heavy duty 600mmx550mmx70mm thick precast Slab in trenches shall be provided and fixed as per instruction of Engineer-in-charge.

2.21. PROVIDING AND LAYING FLOOR HARDENER

Heavy duty non- metallic hardener compound of STP, Roff, Fosroc, CICO of approved manufacture or equivalent laid in panels at all locations over well compacted concrete bed complete with all works, with minimum coverage as per manufacturers' specifications, drawings and as directed by EIC shall be provided and laid. All preparation and laying to be done under specialist supervision and a performance guarantee be furnished for a long term service life.

2.22. GROUTING WITH NON-SHRINKABLE COMPOUND

Brief description of major items shall be as follows:

Ready mix non-shrink cementitious grout of compressive strength 30N/mm² / 45 N/mm² as per SOR shall be provided and laid manually or by pumping at all positions. This shall include shuttering, compacting, edging, repairing, sealing and curing for shutdown repairs, base grouting of rotating equipment and other installation complete. This shall be as per specifications, site sketches/ drawings and direction of the EIC.

Minimum coverage as per manufacturers' recommendations shall be applied in absence of actual field consumption data.

2.23. PROVIDING AND LAYING CAPCELL BOARD

CAPCELL board sealing in expansion joints of 12 mm/25 mm thickness and required depth shall be

provided and laid. All preparation, protection, sealing and sand bed separation will be part of the work.

2.24. SPECIFICATION-PRECAST PANELLED COMPOUND WALL FOR DE-COMPRESSION UNITS

The compound wall shall consist of RCC precast concrete posts of minimum cross sections 140mmX125mm at 1.8 M c/c having two grooves of required size so as to receive precast RCC panels of minimum 50 mm thick. The post shall be reinforced with 4 nos of 10mm dia TMT bars with stirrups. Panels shall be reinforced with minimum 03 nos of longitudinal 8 mm dia TMT steel for panel width 300 mm and distribution 8mm dia bars at 250mm c/c. The RCC for precast posts and panels shall be of M30 grade. The post shall be encased with PCC 1:3:6 in ground for minimum dimensions 600x600x750mm depth.

Note:

Complete civil works for precast panelled compound wall including, earth work in excavation, backfilling, shuttering, RCC, PCC, reinforcement, transportation and erection of posts, panels, etc. are included in the works & payment shall be made in sqm for the laid area above floor level.

LIST OF RECOMMENDED MAKES & MANUFACTURERS

Sl.No	Description	Manufacturers
1	Glazed tiles / Ceramic tiles / Vitrified ceramic tiles	M/s. HR Johnson; M/s. Kajaria Tiles, M/s. Somany Floor & Wall Tiles, Bell-Ceramics, M/s.NITCO, M/s. Murudeshwar Ceramics Ltd.
2	FLOOR HARDENR	CICO, Fosroc,Sika
3	STEEL DOORS, ROLLING SHUTTERS & PRESS STEEL DOOR FRAMES	M/s Shakthi Met-Door, M/s. Madhu Industries, M/s. Deccan Structural Systems Pvt. Ltd., M/s. NCL Seccolor Ltd.,
4	ALUMINIUM DOORS, WINDOWS, CURTAIN WALLS / STRUCTURAL GLAZING USING INDAL / JINDAL / HINDALCO SECTIONS	Indal , Boruka, Hindalco, Jindal M/s. ALFAB Products.

5	GLASS : (Plain/Frosted clear / tinted float glass)	M/s Modigaurd, M/s Saint-Gobain, M/s Asahi, M/s. Hindusthan Safety Glass Works Ltd
6	HARDWARE FITTINGS & FIXTURES:	M/s Shalimar Hardware. M/s Everite, M/s Hardwyn, M/s Earl Bihari, M/s Godrej & Boyce, Secur Industries. M/s EBCO: M/s Godrej & Boyce mfg. Ltd. M/s CROWN
7	EXPANSION JOINT AND TARFELT WATERPROOFING	M/s Shalitek; M/s Tiki Tar industries; M/s STP Ltd. (Ms Shalimar Tar Products); M/s Lloyd Insulation (I) M/s Pidilite M/s IWL
8	INTEGRAL WATER: PROOFING COMPOUND	Accoproof, Cico; Impermo Lafarge, Fosroc, Roffe,Sika,
9	WATERPROOFING TREATMENT	Sika, Fosroc, Roffe, Overseas water proofing corporation, Chowgule Texsa, Pidilite,
10	CEMENT PAINTS, EXTERIOR EMULSION PAINTS, DISTEMPER, ACRYLIC EMULSION PAINTS, ENAMEL PAINTS & FLAT OIL PAINTS	M/s Asian Paints; M/s Berger Paints; M/s Goodlass Nerolac; M/s Jenson Nicholson;
11	FALSE CEILING / PARTITION	India gypsum, Armstrong, Lafarge boral gypsum limited, Luxalon
12	DECORATIVE LAMINATES	Decolam,National, Formica, Greenlam, Century (merino)
13	DOOR CLOSERS, FLOOR SPRING	Everite, Garnish, HARDWYN, DORMA
14	SEALANTS	Ge Silicon, Dow corning, Bostik, Pidlite Industries
15	CONCRETE PAVER BLOCKS	Basant Beton, Cobble stones, Abideep Interlock Pavers, pvt. Ltd., Pave Stone Marketing (P) Ltd., Designers Pavings& Tiles Pvt. Ltd., Bessers Concrete Paver Blocks.
16	SANITARY APPLIANCES	Parryware,Hindustan Sanitary Ware & Industries ltd., Neycer.
17	CP BRASS FITTINGS, WASTE COUPLINGS, BOTTLE TRAPS	Jaquar, Essco, Nova, Gem, Marc, Essess, Jupiter aqua , Grohe.

18	PVC flushing cisterns	Parry ware, Hindware, Neycer
19	Mirror	Saint Gobain, Modigaurd, Atul glass works,
20	Plastic seat and cover	Commander,
21	Stainless Sink	Nirali, Diamond, Jaquar Dayana,Amc, etc.
22	GI Pipes	Tata, Jindal
23	GI Malleable fittings	Unik, Zoloto pec,MJM, Bimal
24	GM gate/ Globe valves	Neta, Sant, New, Leader
25	SW Pipes & Gulley traps	Perfect Kashmira, South India Corporation, TACEL, INDO PIPES
26	HDPE/UPVC Pipes & fittings	Prince, Finolex, Supreme, Kitec, Oriplast, Polyfab,
27	CPVC pipes & fittings	Flowgaurd (ASTRAL), Finolex
28	CI manhole covers	Neco
29	PVC storage tanks	Sintex, Infra, ICP (India) Pvt. Ltd. Century, Polycon
30	CEMENT	ACC, Ambuja Cement. Ultra Tech, Birla super
31	REINFORCEMENT STEEL	SAIL, TATA STEEL, RINL
32	ADMIXTURES	FOSROC,SIKA,ROFF
33	PVC PIPES	SUPREME, INFRA, PRINCE, FINOLEX
34	ANTI TERMITE TREATMENT	PEST CONTROL INDIA LTD, MYSODET LTD., ASHOK PEST CONTROL – HUBLI, PEST CONTROL – PUNE, CHRISLINE MARKETING AGENTS- Bangalore
35	APP modified bitumen water proofing membrane	STP, BITUMAT, SIKA, IWL, PIDILITE TEXSA
36	Wall care putty for base preparation	Birla Wallcare putty, Berger, Johnson and Nicholson, JK white
37	Polysulphide Sealant	Cico, Fosroc, Pidilite, Sika
38	Chain link fencing	Tata

39	PRELAMINATED PARTICLE BOARD	Archidply
40	PRECAST RCC COVER SLAB	NUTEK, Bangalore, For any other make, contractor has to obtain prior approval from /GGPL based on their credentials.
41	CANOPY FALSE CEILING	INTERARCH
42	CANOPY ROOF SHEETING	For any other make, contractor has to obtain prior approval from /GGPL based on their credentials.
43	ACM SHEETING FOR FACIA, SIGNAGES	ALSTONE, For any other make, contractor has to obtain prior approval from /GGPL based on their credentials.
44	RMC CONCRETE PLANT	RMX (Magadi road), SCC READYMIX (Kumblagod, Kengeri Hobli), NEXGEN CONCRETE (Hennur)
45	STRUCTURAL STEEL	SAIL, TATA STEEL, RINL
46	PRECAST CONCRETE PANELS FOR COMPOUND WALL IN DE-COMPRESSION UNI T INSTALLATION	M/S SASICON For any other make, contractor has to obtain prior approval from /GGPL based on their credentials.

TENDER NO: GGPL/KKD/C&P/CW/2523/VS



**QUALITY ASSURANCE &
QUALITY CONTROL**

SITE QUALITY PLAN

CIVIL ENGINEERING DIVISION

TENDER NO: GGPL/KKD/C&P/CW/2523/VS



SL. No	Component/ Operation and Description of test	Sampling plan with basis	Type of check	Instrument	Reference document	Acceptance Norm	Format of Record	Testing agency	Remarks
A: MATERIALS									
1.0	COARSE AGGREGATE								
1.1	Specific Gravity, Density, Voids	Once in 12 weeks or change of source whichever is earlier	Laboratory Test	Weigh balance, Oven, Jar	IS:2386 Part III, IS:456, IS:383			Package Contractor	These test will be carried out while establishing design mix.
1.2	Sieve Analysis	<u>For Industrial Projects:</u> One sample per 200 M ³ (or part thereof) or change of source whichever is earlier. <u>For Building Projects:</u> One sample per 45M ³ (or part thereof)	Field Laboratory Test	Sieve set & weigh balance	IS:383	As per requirement of design mix within the limits specified in relevant IS Codes.	L-04	-do-	Mandatory Site Test
1.3	Petrography examination including visual inspection	To be done once per source	Visual/ Checking	-	IS:2386 Part IV, IS:383 (for acceptance limits)		-	-do-	Test will be carried out while establishing mix design

TENDER NO: GGPL/KKD/C&P/CW/2523/VS

SL. No	Component/ Operation and Description of test	Sampling plan with basis	Type of check	Instrument	Reference document	Acceptance Norm	Format of Record	Testing agency	Remarks
1.4	Deleterious Chemicals	To be done once per source	Lab Test	Balance Sieve & Container	IS:2386 Part III, IS:383 (for acceptance limits)			-do-	Test will be carried out while establishing mix design
1.5	Soundness	To be done once per source	-do-	Sieve Scales & Drying Oven	IS:2386 Part V, IS:383 (for acceptance limits)			-do-	Test will be carried out while establishing mix design
1.6	Acid & Alkali Reactivity	To be done once per source	Lab Test	Weigh balance	IS:2386 Part VII, IS:383			-do-	Test will be carried out while establishing mix design
1.7	Flakiness	To be done once per source	-do-	-	IS:2386 Part-I, IS:2386 Part VII, IS : 383			-do-	-do-

TENDER NO: GGPL/KKD/C&P/CW/2523/VS

SL. No	Component/ Operation and Description of test	Sampling plan with basis	Type of check	Instrument	Reference document	Acceptance Norm	Format of Record	Testing agency	Remarks
1.8	Bulk Density	One Sample per 200 m ³ or part thereof		Oven, Jar & Weigh balance	IS:2386			-do-	-do-
2.0	FINE AGGREGATE								
2.1	Bulkage Moisture	One sample per 20M ³ (or part thereof)	Routine Measurement	Oven, Jar and weigh balance	IS : 2386 Part-III, IS : 383			-do-	Mandatory Site Test. Volume of sand and weight of water shall be adjusted as bulkage & moisture contents.
2.2	Sieve Analysis	<u>For Industrial Projects.</u> One sample per 200 m ³ (or part thereof) or change of source whichever is earlier. <u>For Building Project.</u> One sample per 40 M ³ (or part thereof)	Routine	Sieve Set, Weigh balance	IS : 2386 Part-I, IS : 383	As per requirement of design mix within the limits specified in relevant IS Codes	L - 03	-do-	Mandatory Site Test.
2.3	Particle Size and Shape	To be done once per source and to be repeated if source is changed	Routine	-do-	IS : 2386 Part-I, IS : 383	Particle size shall be maximum 4.75		-do-	To be carried out during mix design.

TENDER NO: GGPL/KKD/C&P/CW/2523/VS



SL. No	Component/ Operation and Description of test	Sampling plan with basis	Type of check	Instrument	Reference document	Acceptance Norm	Format of Record	Testing agency	Remarks
						mm. Grading shall be within the limits of grading zone - III for concrete work and for mortar and grout within the limits of grading zone III & IV.			
2.4	Delete-rious Chemicals	- do-	-do-	Bal-ance, sieve & Container	IS : 2386 Part-III, IS : 383			-do-	To be carried out during mix design.
2.5	Soundness	- do-	-do-	Sieve, Scales & Dry-ing Oven	IS : 2386 Part-V, IS : 383 (for accep-tanc e limit)		-	-do-	To be carried out during mix design.

ANNEXURE - 1 MATERIAL TESTS FOR SITES

SL. No	Component/ Operation and Description of test	Sampling plan with basis	Type of check	Instrument	Reference document	Acceptance Norm	Format of Record	Testing agency	Remarks
2.6	Acid and Alkali Reactivity	To be done once per source and to be repeated if source is changed	-do-	Weigh Balance	IS : 2386 Part-VII, IS : 383		-	-do-	To be carried out during mix design.
2.7	Mortar Making Properties	-do-		Compression testing machine, 7.06 cm cube moulds	IS : 2386 Part-VI, IS : 383		-	-do-	To be carried out during mix design.
2.8	Petrographic Examination including visual inspection	-do-	Visual/ Physical	-	IS : 2386 Part-VI, IS : 383 (for acceptance limit)		-		
2.9	Specific Gravity, Density, Voids	Once in 12 weeks, change of source whichever is earlier	Measurement	Weigh Balance	IS : 2386 Part-III				These tests will be carried out while establishing design mix.
2.10	Check Silt and Clay Content	Every 20M ³ (or part thereof)	Measurement	Jar & Oven	IS : 2386 Part-II, IS : 383	Deleterious material not to exceed 5%	-		Mandatory Site Test

TENDER NO: GGPL/KKD/C&P/CW/2523/VS



SL. No	Component/ Operation and Description of test	Sampling plan with basis	Type of check	Instrument	Reference document	Acceptance Norm	Format of Record	Testing agency	Remarks
3.0	LIME								
3.1	Chemical and Physical Properties	Every 10 MT (or part thereof)	Laboratory Test		IS: 6932 (Part I to X)			- do-	Optional Test if required.
4.0	CEMENT								
4.1	Fineness	For each consignment of 100T (or part thereof).	Laboratory Test		IS : 4031, IS : 269, IS : 1489, IS : 455			Manufacturer/ Package Contractor	Manufacturer's certificate to be furnished.
4.2	Normal consistency	-do-	Laboratory Test	Vicat needle	IS : 4031, IS : 269, IS : 1489, IS : 456			Manufacturer/ Package Contractor	- do-

SL. No	Component/ Operation and Description of test	Sampling plan with basis	Type of check	Instrument	Reference document	Acceptance Norm	Format of Record	Testing agency	Remarks
4.3	Initial and Final setting	-do-	Laboratory Test	Vicat needle	IS : 4031, IS : 269, IS : 1489, IS : 457	Depending on the type of cement and as per relevant IS		Manufacturer/ Package Contractor	- do-
4.4	Soundness, Specific Gravity	-do-	Laboratory Test		IS : 4031, IS : 269, IS : 1489, IS : 458			Manufacturer/ Package Contractor	- do-
4.5	Compressive Strength	Every fortnight for each consignment.	Measurement	Compression Testing Machine	IS : 4031, IS : 269, IS : 1489, IS : 459	Depending on the type of cement and as per relevant IS		Package Contractor	Mandatory Site Test
5.0	CONCRETE								
5.1	Workability, Slump test and compaction factor test	Once a day for each batching/ mixing plant	Measurement		IS : 456, IS : 1199, Client's specification	Degree of workability adopted depending on the type of structure and type of		Package Contractor	Mandatory Site Test

SL. No	Component/ Operation and Description of test	Sampling plan with basis	Type of check	Instrument	Reference document	Acceptance Norm	Format of Record	Testing agency	Remarks
						compaction equipment.			
5.2	Crushing Strength	One set of 6 cubes of 150 cm. Size per 35 Cum. of concrete or part thereof for each grade of concrete per 8 hours of work or portion thereof.	Measurement	Compression Test Machine	IS : 516, IS : 1199, IS : 416 and Client's specification	Shall be as per IS: 456		Package Contractor	Three specimens shall be tested at 7 days and remaining at 28 days. Mandatory Site Test.
5.3	Water Cement Ratio	At random at the time of batching	Measurement	Visual observation	As per approved design mix			Package Contractor	
5.4	Check cement content	-do-	Measurement / by weight batcher		IS : 3025, IS : 456 and approved design mix.			Package Contractor	
6.0	WATER								

TENDER NO: GGPL/KKD/C&P/CW/2523/VS

SL. No	Component/ Operation and Description of test	Sampling plan with basis	Type of check	Instrument	Reference document	Acceptance Norm	Format of Record	Testing agency	Remarks
6.1	Tests for ascertaining limits of solid	Once for each source of supply	-do-	Lab Test	IS : 3026 and Soil investigation record.			Package Contractor	During mix design stage
6.2	Test of pH value	-do-	-do-	PH meter	IS : 456	PH value shall be less than 6.	Site log book		-do-
7.0	BRICK								
7.1	Compressive Strength	<u>For designation 100,</u> Every 50,000 or part thereof. <u>For designation up to 75,</u> Every 100,000 or part thereof.	Compressive strength	Compression Testing Machine	IS: 1077	As per brick designation.			Mandatory Site Test
7.2	Shape, Size, Colour	-do-	Visual & measurement for size		IS: 3495				Mandatory Site Test

SL. No	Component/ Operation and Description of test	Sampling plan with basis	Type of check	Instrument	Reference document	Acceptance Norm	Format of Record	Testing agency	Remarks
7.3	Water absorption and efflorescence	One test for each source of manufacturer and every lot of 200,000.	Routine		IS: 3495	Water absorption: a) after 24 hours not less than 20% by weight b) after 6 hours not less than 10% by weight. c) moderate degree of efflorescence			Mandatory Site Test
8.0	REINFORCEMENT STEEL								
8.1	Tensile Strength	Every 20T or every consignment purchased by Package Contractor	Measurement	Universal Testing Machine	IS: 1599			Manufacturer/ Package Contractor	Manufacturer test certificate must be submitted
8.2	Bend Strength	-do-	-do-		-do-			-do-	-do-

TENDER NO: GGPL/KKD/C&P/CW/2523/VS



SL. No	Component/ Operation and Description of test	Sampling plan with basis	Type of check	Instrument	Reference document	Acceptance Norm	Format of Record	Testing agency	Remarks
8.3	Surface cracks, Rrusts etc.	Random	Visual	Visual					
9.0	TIMBER								
9.1	Moisture Content	Every 1M ³ or part thereof	Measurement	Moisture meter				Package Contractor	Mandatory Test
10.0	FLUSH DOOR SHUTTER								
10.1	End Immersion	N = Total No of Shutters 1 Shutter for N<=65 2 Shutters for 65<N<=180 3 Shutters for 180<N<=300 4 Shutters for 300< N<=500 5 Shutters for N>=501	Destructive Test	At approved test house	IS: 2202			Package Contractor	Mandatory Test
10.2	Knife Test								
10.3	Adhesion Test								
11.0	ALUMINIUM DOORS/ WINDOW FITTINGS								
11.1	Thickness of Anodic Coating	Cost of fittings of every Rs.20,000/- or part thereof	Measurement	At approved test house	IS: 5523			Package Contractor	Mandatory Test

TENDER NO: GGPL/KKD/C&P/CW/2523/VS



SL. No	Component/ Operation and Description of test	Sampling plan with basis	Type of check	Instrument	Reference document	Acceptance Norm	Format of Record	Testing agency	Remarks
14.2	Impact Test	-do-	-do-	-do-	-do-	-do-	-do-	-do-	Optional Test
15.0	MORTICE LOCK								
15.1	Testing of springs	Every 100 locks or part thereof	Measurement	Approved Test House				Package Contractor	Mandatory Test
16.0	BITUMEN								
					IS: 73				
17.0	STORAGE OF MATERIALS								

TENDER NO: GGPL/KKD/C&P/CW/2523/VS



SL. No	Component/ Operation and Description of test	Sampling plan with basis	Type of check	Instrument	Reference document	Acceptance Norm	Format of Record	Testing agency	Remarks
17.1	Cement	100%	Visual		IS: 4082	Covered storage. <input type="checkbox"/> Clear gap of min. 15cm from the floor. <input type="checkbox"/> Space of min. 45cm around the exterior wall. <input type="checkbox"/> Stacking not more than 15 bags high arranged alternately lengthwise and crosswise.			

TENDER NO: GGPL/KKD/C&P/CW/2523/VS



SL. No	Component/ Operation and Description of test	Sampling plan with basis	Type of check	Instrument	Reference document	Acceptance Norm	Format of Record	Testing agency	Remarks
						<input type="checkbox"/> Width of the stack shall not be more than 3 meters			
17.2	Reinforcement	100%	Visual		IS: 4082	Open storage. <input type="checkbox"/> Bars of different classification, sizes and length will be stacked separately.			

TENDER NO: GGPL/KKD/C&P/CW/2523/VS

SL. No	Component/ Operation and Description of test	Sampling plan with basis	Type of check	Instrument	Reference document	Acceptance Norm	Format of Record	Testing agency	Remarks
17.3	Brick	100%	Visual		IS: 4082	Open storage. <input type="checkbox"/> Bricks shall be stacked on dry firm ground. <input type="checkbox"/> Stacks shall be 50 bricks long and 10 bricks high. <input type="checkbox"/> Bricks shall be placed on edge. <input type="checkbox"/> Width of each stack shall be two bricks.			

TENDER NO: GGPL/KKD/C&P/CW/2523/VS



SL. No	Component/ Operation and Description of test	Sampling plan with basis	Type of check	In-stru-ment	Re-fer-ence docu-ment	Accep-tance Norm	Format of Record	Test-ing agency	Remarks
17.4	Aggregates	100%	Visual		IS: 4082	<ul style="list-style-type: none"><input type="checkbox"/> Shall be stored at site on a dry ground/ platform of planks/ old corru-gated iron sheets/ floor of bricks/ thin layer of lean concrete.<input type="checkbox"/> Stacks of fine ag-gregate and coarse aggregate shall kept in sepa-rate stockpiles.			

TENDER NO: GGPL/KKD/C&P/CW/2523/VS



SL. No	Component/ Operation and Description of test	Sampling plan with basis	Type of check	Instrument	Reference document	Acceptance Norm	Format of Record	Testing agency	Remarks
17.5	Other Bought Out Items	100%	Visual		IS: 4082	Covered storage. Materials shall be stored as per manufacturer's specification.			
18.0	PILING								
18.1	PLANT & MACHINERY								

TENDER NO: GGPL/KKD/C&P/CW/2523/VS



SL. No	Component/ Operation and Description of test	Sampling plan with basis	Type of check	In-stru-ment	Re-fer-ence docu-ment	Accep-tance Norm	Format of Record	Test-ing agency	Remarks
	<input type="checkbox"/> Concrete mixer <input type="checkbox"/> Vibrators of adequate capacity <input type="checkbox"/> Power driven rigs of adequate capacity <input type="checkbox"/> Weigh Batches <input type="checkbox"/> Lighting <input type="checkbox"/> Mobile Cranes		Visual/ Physical						
19.0	CONSTRUCTION OF PILE								
19.1	SPT values during boring operation	100%							

TENDER NO: GGPL/KKD/C&P/CW/2523/VS



SL. No	Component/ Operation and Description of test	Sampling plan with basis	Type of check	Instrument	Reference document	Acceptance Norm	Format of Record	Testing agency	Remarks
19.2	Tolerances in position	100%	Measurement	Measuring Tape	IS: 2911 (Part I/ Sec2)	<p>Piles <600mm: 75mm or D/4 whichever is less.</p> <p>Piles >600mm: 75mm or D/10 whichever is more.</p> <p>For single pile: <600mm: 50mm or D/4 whichever is less. >600mm: 100mm.</p>		Piling Contractor	
19.3	Control of alignment	100%	Measurement	Measuring Tape	IS: 2911 (Part I/ Sec2)	<p>Vertical pile: 1.5 % deviation maximum.</p> <p>Raker pile: 4%</p>			

TENDER NO: GGPL/KKD/C&P/CW/2523/VS



SL. No	Component/ Operation and Description of test	Sampling plan with basis	Type of check	In-stru-ment	Re-fer-ence docu-ment	Accep-tance Norm	Format of Record	Test-ing agency	Remarks
19.4	Chipping of pile top	100%				Manual chipping after 3 days of casting. Pneumatic tools after 7 days of casting.			
20.0	BENTONITE SUSPENSION:								
20.1	Liquid limit		Measurement			>300% <400%		Piling Contractor	
20.2	Sand content of Bentonite powder		-do-			Not more than 7%		-do-	
20.3	Density of freshly prepared Bentonite suspension		-do-	Hydrometer	IS:9556	Between 1.034 and 1.10gm/ ml.		-do-	Shall be recorded for initial 10 piles and subsequently at every 10 th pile.
20.4	Marsh viscosity		-do-	Marsh cone		Between 30 and 60 sec		-do-	

TENDER NO: GGPL/KKD/C&P/CW/2523/VS



SL. No	Component/ Operation and Description of test	Sampling plan with basis	Type of check	Instrument	Reference document	Acceptance Norm	Format of Record	Testing agency	Remarks
20.5	PH value of Bentonite suspension		-do-	PH indicator paper strip		Between 9 and 11.5		-do-	
20.6	Density after mixing with deleterious material		-do-	Hydrometer		Maximum. 1.25gm/ ml.		-do-	Shall be recorded for initial 10 piles and subsequently at every 10 th pile.
21.0	PILE TESTING								

TENDER NO: GGPL/KKD/C&P/CW/2523/VS



SL. No	Component/ Operation and Description of test	Sampling plan with basis	Type of check	Instrument	Reference document	Acceptance Norm	Format of Record	Testing agency	Remarks
21.1	Vertical Load Test (for both test & job piles)	Test pile. No of pile to be tested shall be minimum one.	Testing	Dial Gauge (Sensitivity of dial gauge : 0.01 mm)	IS:2911, Part-IV	Safe load shall be minimum of the following: (a)2/3 rd of final load against total displacement of 12 mm. (b) 50% of final load against total displacement of 10% of pile diameter.		Piling contractor	

TENDER NO: GGPL/KKD/C&P/CW/2523/VS



SL. No	Component/ Operation and Description of test	Sampling plan with basis	Type of check	Instrument	Reference document	Acceptance Norm	Format of Record	Testing agency	Remarks
		Working pile. No of piles to be tested shall be minimum 1/2 % of total no of piles.	-do-	-do-	-do-	Maximum settlement shall not exceed 12 mm against test load 150% of working load.		-do-	
21.2	Lateral load test	Optional	Testing	-do-	IS:2911, Part-IV	Safe load shall be minimum of the following: (a) 50% of the final load against total displacement of 12 mm. (b) Final load against total displacement of 5 mm		-do-	

ANNEXURE - 1 MATERIAL TESTS FOR SITES

SL. No	Component/ Operation and Description of test	Sampling plan with basis	Type of check	Instrument	Reference document	Acceptance Norm	Format of Record	Testing agency	Remarks
21.3	Pull out Test	Optional	Testing	-do-	IS:2911, Part-IV	Safe load shall be least of the following: (a) 2/3rd of total load against displacement of 12mm. (b) Half of the load at which load displacement curve breaks		-do-	Initial test shall be carried out up to twice the estimated safe load. Routine test shall be carried out to 150% of the estimated safe load or 12mm total displacement.

ANNEXURE - 2 TESTING EQUIPMENT FOR SITES

S L N O	BROAD CLASS	NOMENCLATURE DESCRIPTION	UTILITY	TEST PROCE- DURE	REFER- ENCE DOCU- MENT	TO BE AVAIL- ABLE AT SITE
1.0	ROUTINE TEST LAB. EQUIPMENT	1.1 Vicat Apparatus	Cement consis- tency & Penetra- tion	Penetration of Std. Needle	IS : 5513	Yes
		1.2 Lechatelier's test Apparatus	Cement shrinkage	Size variation after curing of sample	IS : 5514	Yes
		1.3 Mould (Cement) (70.7x70.7x70.7 mm)	Cement cubes	Cubes made of 1:3 cement : Sand	IS : 10086	Yes
		1.4 Cement Mortar Mould Vibrator	Cube compaction	Vibration for fixed duration	IS : 10078	Yes
		1.5 Concrete Cube mould (150x150x150) mm	Concrete Cubes	-	IS : 10086	Yes
		1.6 Compressive strength Test- ing machine	Concrete Cube Test	Crushing strength of cube	IS : 2505	Yes
		1.7 Concrete slump cone	Workability Check	Drop in cone height of concrete	IS : 7320	Yes
		1.8 Coarse aggregate sieves	Sieve analysis	Sieving	IS : 383	Yes
		1.9 (a) Soil Core cutter (b) Proctor Compac- tion	To test compaction of soil	Core cut out of soil and density measured	IS : 2720	Yes
		1.10 Fine aggregate sieves	Sieve analysis	Sieving	IS : 383	Yes
		1.11 Sieve shaker	Mechanical sieving	-	-	Yes
		1.12 Aggregate impact Test Machine	Impact value of aggre- gate	-	IS : 9377	Yes

TENDER NO: GGPL/KKD/C&P/CW/2523/VS



2.0	DIMENSION- AL & ALLIED MEASUR- ING EQUIP- MENT	2.1 Theodolite & levelling staff	Levelling and centre line marking and verticality measurement	Measurement and recording	-	Yes
		2.2 Measuring Tape	Dimension	-	-	Yes

ANNEXURE - 2 TESTING EQUIPMENT FOR SITES

S L N O	BROAD CLASS	NOMENCLATURE DESCRIPTION	UTILITY	TEST PROCE- DURE	REFER- ENCE DOCU- MENT	TO BE AVAIL- ABLE AT SITE
		2.3 Laser Beam apparatus	Verticality of structures	Centre line alignment	-	Yes
3.0	PROCESS CONTROL ACCESSORIES	3.1 Oven	Material Drying for moisture control	Material to be kept for specific duration	-	Yes
		3.2 Physical balance	Weighing	-	-	Yes
		3.3 Air entrainment meter	To determine % of air in fresh concrete mix	Samples of fresh concrete to be taken and tested in the equipment	IS : 1199	Yes
4.0	SPECIAL TEST EQUIP- MENT	NDT 4.1 Rebound hammer	Strength test of concrete	Rebound of the ball is proportional to the strength of concrete	-	Yes
		4.2 Ultrasonic test for concrete	Test for porosity for concrete	Speed of the ray transmitted through the concrete indicates the extend of porosity	-	Yes
		4.3 Profometer/Micro covermeter	Location & diameter of reinforcement	Variation in density used to detect steel location	-	Yes
		D.T. 4.4 Portable electrically operated concrete core cutter	Strength of In-situ concrete	Core cut out of concrete tested for strength	-	Yes

TENDER NO: GGPL/KKD/C&P/CW/2523/VS



SL. No	Description of Site Activity	Workmanship Checks to be undertaken	Remarks
1	Earth work	(a) Classification of Soil, for payments, if required. (b) Line & level. (c) Disposal lead. (d) Levelling at Disposal Yard. (e) Initial & Final level in Level Book. (f) Rolling/Tamping/Compaction of Fills, as per IS : 2720 (g) Arrangement for de-watering. (h) Shoring & Strutting. (i) Safety (side slopes, ramps, working space around foundation, dumping at safe distance beyond top edge). (j) Excess excavation depth properly filled for foundation works. (k) Foundation bed level, bearing capacity conformance.	

TENDER NO: GGPL/KKD/C&P/CW/2523/VS



SL. No	Description of Site Activity	Workmanship Checks to be undertaken	Remarks
2	Piling Work	<ul style="list-style-type: none">a) Diameter of Pile.b) Depth Driver.c) Sequence of driving in a pile group.d) Set for last 10 blows or as specified.e) Type and size of hammer and its stroke, in case of double acting hammer, No. of blows per minute & stroke.f) Type and condition of packing on the pile head and or dolly in the hammer.g) Driving resistance record through variable strata in case of driven cast-in-situ pile.h) Bore log in case of Bored pile.i) Density of slurry in case of Bentonite slurry pile.j) Date & time of driving.k) Date of concreting & time gap between end of driving & concreting.	

TENDER NO: GGPL/KKD/C&P/CW/2523/VS



SL. No	Description of Site Activity	Workmanship Checks to be undertaken	Remarks
		l) Standing ground water level. m) Ground level at the commencement. n) Length of Pile. o) Length of Permanent casing. p) Set at intervals during last 3 Meters. q) Concrete Mix. r) Details of Reinforcement. s) Volume of Concrete supplied to pile against theoretical volume. t) Water tightness of pile before concreting. u) Eccentricity v) Deviation for Verticality. w) Condition of pile head at cut-off. x) Routine load test results. y) Initial load test results. z) Integrity test results of each pile.	

TENDER NO: GGPL/KKD/C&P/CW/2523/VS



SL. No	Description of Site Activity	Workmanship Checks to be undertaken	Remarks
3	Concret-ing Works	<p>(a) Check quality and size of coarse aggregate with special reference to undersize/oversize materials, disintegrated/self materials, earth and other foreign materials beyond limit, organic impurities.</p> <p>(b) Fineness modulus of sand, silt content, bulkage, foreign materials in sand.</p> <p>(c) Check formwork.</p> <p>(d) Line, level of concrete.</p> <p>(e) Honeycombed surface in concrete.</p> <p>(f) Strength of Concrete.</p> <p>(g) Check Mix Boxes.</p> <p>(h) Mixing of concrete by hand/machine.</p> <p>(i) Use of Vibrator.</p> <p>(j) Slump of concrete.</p>	

TENDER NO: GGPL/KKD/C&P/CW/2523/VS



SL. No	Description of Site Activity	Workmanship Checks to be undertaken	Remarks
4	Formwork	<ul style="list-style-type: none">a) Line, level and dimensions as per drawing.b) Cross bracing of supporting framework.c) Diagonal bracings.d) Ground support rigidity to avoid settlement.e) Plumbness of shores.f) Wedge tightening of shores.g) Thickness of shutter to withstand pressure of wet concrete.h) Leakproofness of shutter (IS : 457)i) Demoulding agent/Oiling of shutter.j) Facility for removal of formwork in proper sequence.k) Avoid premature removal.	

SL. No	Description of Site Activity	Workmanship Checks to be undertaken	Remarks
5	Reinforced Concrete Works	<ul style="list-style-type: none">a) Sieve analysis of coarse aggregate to check oversize, undersize, improperly graded aggregate.b) Check presence of disintegrated/soft or foreign materials in aggregates.c) Quality of sand, Silt content, Bulkage test.d) Quality of Cement and age of Cement (1st in 1st OUT system)e) Quality of water for mixing and curing.f) Slump test.g) Cube Tests.h) Cover Block thickness and integrity (cover not reduced more than 2mm or increased by more than 10mm).i) Whether reinforcement exposed on removal of forms.j) Tensile testing of steel reinforcement, as required.k) Gauge of binding wire and its use at all joints.l) Reinforcement placement as per drawing and top reinforcement to be supported by chairs etc.	

TENDER NO: GGPL/KKD/C&P/CW/2523/VS



SL. No	Description of Site Activity	Workmanship Checks to be undertaken	Remarks
		<ul style="list-style-type: none">m) Spacing of laps and staggering and length of lap.n) Mix design record/requirements.o) Rigidity and evenness of centring & shuttering.p) Finish requirement of surface.q) Throating and moulding requirements as per drawings.r) Line and level requirements as per drawing.s) Expansion joint contraction, joint provisions.t) Fixing of inserts, conduits, bolts to proper alignment.u) Hacking of green concrete for future plastering.v) Adequate curing.w) Corrosion protection requirements of reinforcement.x) Drainage provisions on roof surface (slope & spout)y) Gangway placement for concreting to be independent of reinforcement.z) Rigidity of reinforcement cage to avoid distortion during concreting	

TENDER NO: GGPL/KKD/C&P/CW/2523/VS



SL. No	Description of Site Activity	Workmanship Checks to be undertaken	Remarks
		<p>aa) Compaction requirements of concrete by needle vibrators/Form vibrator etc.</p> <p>bb) Provisions at construction joint - Waterbar - Nozzles etc.</p> <p>cc) Provision of dowel bars 12mm <input type="checkbox"/> 300 long (400mm either side) at Φ C/C on construction joint surface.</p>	

TENDER NO: GGPL/KKD/C&P/CW/2523/VS



SL. No	Description of Site Activity	Workmanship Checks to be undertaken	Remarks
6	Brickwork	<ul style="list-style-type: none">(a) Quality of bricks for strength, dimensional accuracy, efflorescence water absorption and evenness of backing.(b) Sand quality for fineness modulus and Silt content.(c) Cement quality.(d) Mixing of Mortar to structural space.(e) Thickness of joint not exceeding 10mm.(f) Raking of joints in green stage by raking tool (15mm deep)(g) Filling of vertical joints properly.(h) Soaking of bricks.(i) Line and level of brickwork.(j) Plumbness.(k) Brick corners are provided with proper brick closer not by brick bat.(l) Top coarse in plinth, windowsill, below RC slab and parapets are with brick on edge.	

TENDER NO: GGPL/KKD/C&P/CW/2523/VS



SL. No	Description of Site Activity	Workmanship Checks to be undertaken	Remarks
		<ul style="list-style-type: none">(m) Type of scaffolding.(n) Filling of scaffolding potholes.(o) Brick coarses are in level.(p) Proper bonding of main wall with cross wall (No toothing joints)(q) Brickwork taken-up in layers not exceeding 1 Metre.(r) Proper provision of reinforcement in brick-wall.(s) Lateral bonding of brick-wall to steel/concrete columns.(t) Filling-up voids between brick -wall and door/windows shutter.(u) Adequate curing of brickwork.	

TENDER NO: GGPL/KKD/C&P/CW/2523/VS



SL. No	Description of Site Activity	Workmanship Checks to be undertaken	Remarks
7	Stone Masonary Work	(a) Quality of stone. (b) Strength of Mortar. (c) Mix of Mortar. (d) Quality of Sand - Silt content & fineness modulus. (e) Whether joints fully filled with Mortar. (f) Whether required number of bond stones provided (Marking of bond stone during construction needed for easy identification). (g) Extent of spalls in hearting. (h) Line, Level, Thickness. (i) Joint thickness (whether excessive thick)	

TENDER NO: GGPL/KKD/C&P/CW/2523/VS



SL. No	Description of Site Activity	Workmanship Checks to be undertaken	Remarks
8	Flooring Work		
8.1	Cement Concrete Floor	(a) Aggregates, Sand - refer PCC Works. (b) Strength. (c) Thickness. (d) Hardener type and mix. (e) Panel size. (f) Curing arrangement. (g) Polishing requirement.	

TENDER NO: GGPL/KKD/C&P/CW/2523/VS



SL. No	Description of Site Activity	Workmanship Checks to be undertaken	Remarks
8.2	Cast in situ Mosaic Floor	a) Aggregates, Sand - refer PCC Works. b) Strength. c) Thickness. d) Hardener type and mix. e) Panel size. f) Curing arrangement. g) Polishing requirement.	

TENDER NO: GGPL/KKD/C&P/CW/2523/VS



SL. No	Description of Site Activity	Workmanship Checks to be undertaken	Remarks
8.3	Terrazzo Tile Floor	(a) Quality of Lime. (b) Strength test of tile. (c) Abrasion test of tile. (d) Thickness of Joint & Colour matching. (e) Polishing by 80, 120, 320 Grade Carborandum. (f) Any hollow sound when tapped. (g) Curing arrangement.	
8.4	Glazed Tile Floor	(a) Size of Tile (b) Thickness of Tile (\pm 0.5 mm) (c) No glazed surface at edges. (d) Free from crazing.	

TENDER NO: GGPL/KKD/C&P/CW/2523/VS



SL. No	Description of Site Activity	Workmanship Checks to be undertaken	Remarks
9	Woodwork	<ul style="list-style-type: none">a) Specified timber is used.b) Grade of Wood.c) Free from cracks, dead knots etc. as per grade specification.d) Seasoning done or not.e) Moisture content by moisture meter.f) Lines, level and smoothness of finish & planning.g) Glue utilised in joints or not and whether bamboo pin (min. 10mm dia.) used in joint.h) Tolerance of finished size.i) Use of preservative against masonry surface.j) Size of Holdfasts as per Specification.k) Thickness and dimension of shutter in door panels.l) Thickness of glass panels and quality of glass.m) Whether Putty provided between glass-pane and sash bar & glass pane and beading (No rattling sound when tapped).	

TENDER NO: GGPL/KKD/C&P/CW/2523/VS



SL. No	Description of Site Activity	Workmanship Checks to be undertaken	Remarks
		<ul style="list-style-type: none">n) Whether healing in flush door is of specified type solid core, hollow, particle board etc.o) Quality of Ply and Glue in flush door (Not Urea formaldehyde).p) Destruction test of flush door (End emersion, Knife test etc.)q) Fitting quality and number as per Specification.r) Surfacing of steel fittings as per specification (bright, black Japan, black enamelled, oxidised) and plate thickness.s) Anodising thickness of aluminium fittings.t) Type of brass fittings (Extruded/Cast) with plate thickness.u) Check whether top & bottom surface of shutter properly painted or note.v) Painting of shutter to be done after checking of Knots etc.w) Provision of Chits and Sand blocks.x) Quality of Mesh in meshed shutter (No. of mesh/Sq.inch.) and folding of mesh at the edges before fixing.	

SL. No	Description of Site Activity	Workmanship Checks to be undertaken	Remarks
10.	Steel doors /Windows /grills	a) Size of frame and corner welding of frames (Flush butt welded as per specification) b) Proper fixing of Hinge. c) Primer Coating. d) Provision of Tie Rod at bottom of Door frame for proper size maintenance during fixing. e) Line, Level & Plumb. f) Quality of friction hinges. g) Quantity of Putty (□ 185 Gm. Per Meter length) and painting of Putty within 2 weeks. h) Number of glazing Clips (4 to 6). i) Provision of metal beadings as per specification. j) Material of striking plate in windows (brass or not as per specification) k) Welding of grill before fixing glazing without deformation of frame. l) Length of screws for fixing grills to windows frames.	

TENDER NO: GGPL/KKD/C&P/CW/2523/VS

SL. No	Description of Site Activity	Workmanship Checks to be undertaken	Remarks
11.	Painting work	(a) Name of Manufacturer, Specification, Batch Number, Colour, Date of Manufacture, ISI Marking on Paint Contai (b) Cracks, voids, pores on masonry surface properly filled. (c) Nail-holes, cracks on wood surface properly filled. (d) Steel surface preparation, sand blasting, derusting etc. as per Specification. (e) Soundness and adherence of Old Paint. (f) Paint quality (No. adulteration by thinner) and quality of Primer. (g) Application of each coat of Paint for uniformity, paint drop, dabs, brush-marks, waves and variation of colour. (h) Difficult to reach areas like edges, corners, nuts, bolts etc. are properly painted. (i) Spilled Paints on floors & walls properly cleaned. (j) Painting of fan hooks and exposed surfaces of inserts as per Specification.	

TENDER NO: GGPL/KKD/C&P/CW/2523/VS

SL. No	Description of Site Activity	Workmanship Checks to be undertaken	Remarks
12	Roofing Works	(a) Slope of roof. (b) Quality of Lime, Waterproofing materials etc. as per Specification. (c) Size & quality of brick ballast. (d) Weight & quality of bitumen felt. (e) Over-lapping of bitumen felts. (f) Test by ponding with water. (g) Formation of ridges & valleys. (h) Drip course provision. (i) Embedding of felt at vertical wall. (j) Hollering at the vertical turning point below felt. (k) Grouting of rainwater pipe. (l) Proper termination of Tarfelt near RWP.	

TENDER NO: GGPL/KKD/C&P/CW/2523/VS



SL. No	Description of Site Activity	Workmanship Checks to be undertaken	Remarks
13	Water Supply & Sanitary works	<ul style="list-style-type: none">(a) Quality of G.I. Pipe with original colour paint for class of pipe and IS Mark on surface of pipe.(b) Joining of pipe with white lead and jute yarn on threads.(c) Pipes are approachable for future maintenance.(d) Provision of union at each Stop Cock.(e) Supporting pipes with clamps suitably embedded & jammed in wall(f) Quality/Weight of water-tap, Stop Cocks, Ball Valves and Water Supply fittings as per Specification and ISI Mark.(g) Provision of Vent. Pipe above Overhead Tank to avoid Airlock.(h) Leading over-flow pipe from Tank upto roof drain spout.(i) Mosquitoproof cemplings at over flow pipe of Tank & Cisterns.(j) Quantity of lead provided at Spigot & Socket joints of pipes.(k) Internal surface of HCI Pipes to have painting with Dr. Angus Smith Solution.(l) Hydraulic testing of Water Supply system.	

SL. No	Description of Site Activity	Workmanship Checks to be undertaken	Remarks
		<p>(m) Proper quality HCI Pipes used (Dimension, Weight, Finish, ISI Marks etc.) in Sewage System (C.I. Rain-water pipes) are not used in Sewage System.</p> <p>(n) Flushing test of flushing Cistern.</p> <p>(o) Hume Pipe Class, makes, dimension and test certificate.</p> <p>(p) Stone ware pipe make, dimension, finish, glazing and conforming to Class AA/Class A as per Specification.</p> <p>(q) Quality of Line and level of system.</p> <p>(r) Floor tap water-seal to be minimum as per Specification.</p> <p>(s) Manhole covers, road gully groutings weight, sizes, make & finish.</p> <p>(t) Commercial quality ceramic fittings are not used.</p> <p>(u) Brand name, quality, dimension, colour, ISI marking for sanitary fixtures as per Specification.</p> <p>(v) Static head water test for HCI Pipe in section (4.5 Metres)</p> <p>(w) Test Performance for Water closets (six pieces of toilet papers 150 x 115mm flushed completely 3 times out of 4 trials) Water supply network tested to a pressure of 10 Kg/Cm² before taking over the system.</p>	

TENDER NO: GGPL/KKD/C&P/CW/2523/VS

FORMAT NO.L -01

DETERMINING THE GRADING OF SAND (FINAL AGGREGATE)

Date of Testing:	gms.		WT.RETAINED	PERCENTAGE	Type of aggregate	PERCENTAGE PASSING	REMARKS (GRADING ZONE)
Wt. Of samples:	SI.N O.	RETAINED ON IS SEIVE NO.	WT.RETAINED	WT. RETAINED	CUMULATIVE % WT. RETAINED		
	1	10 mm					
	2	4.74 mm					
	3	2.36 mm					
	4	1.18 mm					
	5	600 microns					
	6	300 microns					
	7	150 microns					
	8	75 microns					

REFERENCE GRADING ZONES OF FINAL AGGREGATE (IS 383)

IS SEIVE DESIGNATION	GRADING ZONE I	GRADING ZONE II	GRADING ZONE III	GRADING ZONE IV
10mm	100	100	100	100
4.75 mm	90-100	90-100	90-100	95-100
2.36 mm	60-95	75-100	85-100	95-100
1.18 mm	30-70	55-90	75-100	90-100
600 microns	15-34	35-59	60-79	80-100
300 microns	5-20	8-30	12-40	15-50
150 microns	0-10	0-10	0-10	0-15

TENDER NO: GGPL/KKD/C&P/CW/2523/VS



FORMAT NO.L-02

METHODS OF DETERMINING THE GRADE OF COARSE AGGREGATE

Date of Testing:					Type of aggregate	PERCENTAGE PASSING	REMARKS (GRADING ZONE)
Wt. Of samples:							
gms.	RETAINED ON IS SEIVE NO.	WT.RETAINED	PERCENTAGE WT. RETAINED	CUMULATIVE % WT. RETAINED			
SI.N O.							
1	40 mm						
2	20 mm						
3	16 mm						
4	12.5 mm						
5	10 mm						
6	4.75 mm						
7	2.36 mm						

GRADING ZONES OF COARSE AGGREGATE (IS 383)

IS SEIVE DESIGNATION	40 mm	20 mm	16 mm	12.5 mm
40 mm	95-100	100	-	-
20 mm	30-70	95-100	100	100
16 mm	-	-	90-100	-
12.5 mm	-	-	-	90-100
10 mm	10-35	25-55	30-70	40-85
4.75 mm	0-5	0-10	0-10	0-10
2.36 mm	-	-	-	-



TENDER NO: GGPL/KKD/C&P/CW/2523/VS

FORMAT NO.L-03

DATE :						
<u>COMPRESSIVE STRENGTH OF CEMENT</u>						
CONCRETE AGENCY :						
LOCATIONS :						
CUBE SIZE :						
DATE OF CAST :						
TYPE OF CEMENT :						
GRADE OF CONCRETE :						
WATER/ CEMENT RATIO :						
ADDITION OF PLASTICIS- ER :						
WEIGHT OF CUBE :						
CUBE TEST				7 DAYS STRENGTH		28 DAYS STRENGTH
SL. NO	MARK	DATE	SLUMP	FAILURE LOAD (KN)	STRENGTH (Kg/Cm²)	FAILURE LOAD (KN) STRENGTH (Kg/Cm²)
1						
2						
3						
4						
5						
6						
PERIOD	SPECIFICATION			ACTUAL (AVERAGE)		
7 DAYS	Kg/Cm ²			Kg/Cm ²		
28 DAYS	Kg/Cm ²			Kg/Cm ²		

TECHNICAL SPECIFICATION

FOR

STEEL STRUCTURAL WORKS SPECIFICATION

FOR FABRICATION, ERECTION AND PAINTING

OF

STEEL STRUCTURES

Contents

GENERAL.....

SECTION-1 FABRICATION OF STEEL STRUCTURES

SECTION 2 ERECTION OF STEEL STRUCTURE.....

SECTION-3 PAINTING OF STEEL STRUCTURES

ANNEXURE-A

ANNEXURE –B.....

ANNEXURE – C

ANNEXURE – D.....

ANNEXURE – E

ANNEXURE - F

1.0 GENERAL

1.1 This specification shall apply to steelwork in Canopy Structures and general structural works for the following Units :

A) Structural unloading platforms , gates and pipe supports in 6 nos. of De-compression unit installations

B) Canopy, Loading platform , gates and pipe supports in 3 nos. of CNG mother stations.

SECTION-1 FABRICATION OF STEEL STRUCTURES

2.0 SCOPE OF WORK

2.1 The scope of work under fabrication includes, but not limited to, the following:

- a) Preparation and submission of material indents, bolt lists and bought-out items list.
- b) Procurement and Supply of Colour coated sheets for structures including packing, loading, transportation, unloading, stacking & storing on skids or supports at site.
- d) Procurement and supply of all consumables like bolts nuts, hooks, Polycoated hook bolts, washers, electrodes, paints, shims, packs, etc., taking into consideration allowance for spares and wastage.
- e) Preparation and submission of fabrication drawings (based on Design drawings) assembly drawings for sheeting, modification / rectification sketches, erection drawings, as-built drawings, bill of materials, bolts lists and shipping documents for approval of purchaser.
- f) Submission of design calculation for non-standard connections, temporary bracings etc. for approval of purchaser.
- g) Cold straightening of section and plates, whenever they are bent and kinked.
- h) Fabrication of all steel structural components covered under design drawings including M S, G I Gratings are generally described under the scope of the project.
- i) Making arrangements for and conducting tests, such as chemical analysis, physical and Mechanical tests on raw materials where specified/as directed by the Purchaser/Consultant. The scope of testing includes conducting tests at shop as well as at site in line with the instruction of Purchaser/Consultant.
- j) Making arrangements for providing all facilities for conducting ultrasonic, X-ray or gamma ray tests of welds, getting the tests conducted by reputed testing laboratories

TENDER NO: GGPL/KKD/C&P/CW/2523/VS

- making available test films / graphs, reports and interpretation. The scope of testing includes conducting tests at shop as well as at site in line with the instruction of Purchaser/Consultant.
- k) Controlled Assembly of steel structural components at shop, wherever required.
 - l) Preparation of steel structural surfaces for painting as provided in the specifications / drawings.
 - m) Application for one primer coat of painting at shop, as specified in the design drawing/specifications.
 - n) Loading, transportation from fabrication workshop to site of erection and unloading of all steel structural components / units / assemblies, Colour coated sheets, FRP sheets and their erection complete with all fittings and fixtures.
 - o) Receipt of free issue items if any from Purchaser's place, handling and unloading at site and fabrication/erection.
 - p) Dismantling wherever required and disposal of debris at a place designated by Purchaser or re-erection of the same as instructed by Purchaser.
 - q) Rectification of damaged structures including fixing, aligning, levelling, bolting and welding etc.
 - r) Preparation of "As-built" drawings.

3.0 PREPARATION OF FABRICATION AND ERECTION DRAWINGS

3.1 Fabrication drawings shall be prepared based on design drawings of steel structures.

3.2 Drawing shall be prepared in metric system as per IS:696-1972 and IS:813-1986. The fabrication drawings shall specify the following details:-

- (a) Type, size and length of welds in case of welded connections,(specifying clearly shop or site weld). Length of weld specified shall be effective length (excluding end crates).
- (b) In case of bolted joints, arrangement of bolts and specification of bolts, nuts etc.(specifying clearly shop and site bolts).
- (c) Specification of electrode/wire flux.
- (d) If required special provision to be mentioned in the drawings for handling of structures during and after fabrication.
- (e) Specification of paint and corresponding surface preparation for painting.
- (f) General arrangement/marketing plan.

TENDER NO: GGPL/KKD/C&P/CW/2523/VS

- (g) Reference to design drawings.
- (h) Material list indicating mark number-wise material requirement giving size, weight, material specification, identification number of each items, number of pieces required etc.
- (i) Layout with all connecting members with blown up joint details wherever required, in order to specify clearly various fabrication and erection requirements as per design drawings.
- (j) Specification of preparation of mating surfaces in case of connection by HSFG bolts.
- (k) Appropriate edge preparation in case of butt/groove welds in accordance with IS:9595-1996, for all plates and sections having thickness greater than 8 mm.
- (l) Erection clearances in order to facilitate smooth erection at site (ref clause no.17.2.2.of IS: 800- 2007).
- (m) Each erection piece shall be clearly identified by an erection mark in these drawings. All loose members shall be given part mark, which shall be 'wired on' the main erection piece for despatch.

- 3.3** Fabrication drawings shall be prepared in such a manner that structures can be dispatched from fabrication shop to erection site with maximum economic transportable size, so as to reduce work involved at site to a minimum.
- 3.4** Bracings shall be connected for 50% of the capacity of the member or the force specified in the design drawing, whichever is more.(for single angle bracing member, consider full area as effective for this purpose).
- 3.5** Standard simple beam connections, unless otherwise stated in the drawings, shall be designed and detailed for 60% beam shear / moment carrying capacity.
- 3.6** Wherever there is risk of nuts becoming loose due to vibration, lock nuts shall be provided, or nuts shall be welded after alignment and tightening.
- 3.7** For all connections by permanent bolts, two nos. of washers shall be used. One washer bearing against the head and the other bearing against the nut.
- 3.8** Detailing of structural steel members subject to dynamic loading shall be such as to ensure smooth transition of load, as well as best behaviour under stress due to fatigue. Welding across tension flange of crane girders is not permitted.
- 3.9** For detailing connection, the allowable stress for materials, welds, bolts etc, shall be as per IS:800- 2007 and IS:816-2007, or as specified in the drawing.

3.10 The contractor shall be responsible for design and detailing all connections. The design of connection shall provide adequate strength for transfer of force in the structural elements, as indicated on design drawings. Detailing shall be such that erection shall be convenient and free from all interfaces, drilling and cutting at site.

4.0 MATERIALS

4.1 Structural Steel

Structural steel and other related materials for construction shall conform to **ANNEXURE-F**.

4.1.2 Due to non-availability of specified materials, suitable substitutions may be provided with the consent of the purchaser. Such substitution shall be incorporated in the "As-built" drawings.

4.1.3 All the items are to be cut as per requirements of the drawing. If joints are to be provided in any item, in order to meet requirements of size and shape, cutting plan showing locations of joints shall be prepared for consideration of purchaser. Joints provided shall be incorporated in "As-built" drawings.

4.1.4 Rolling and cutting tolerances shall be as per IS: 1852:1985.

4.1.5 Only tested materials shall be used unless use of untested materials for certain secondary structural members is permitted by purchaser. If test certificate for the material is not available from the main producer, the following tests shall be carried out at the discretion of the purchaser.

- (a) Chemical Composition
- (b) Mechanical Properties
- (c) Weld ability test

4.1.6 Where steel castings are to be used the same shall conform to IS: 1030:1998

4.2 Bolts and Nuts

4.2.1 Black hexagonal bolts, nuts and lock-nuts shall conform to IS:1363(Part1to3):2002

4.2.2 Precision and semi-precision hexagonal bolts, screws, nuts and lock-nuts shall conform to IS:1364(Part 1 to 6):2002.

4.2.3 High tensile friction grip bolts shall conform to IS:3757:1985 and high strength structural nuts shall conform to IS:6623:2004, and hardened steel washers to IS: 6649:1985.

4.3 Electrodes

4.3.1 Mild steel electrodes and high tensile steel electrodes shall conform to IS:814:2004. Electrode to be used for submerged arc welding shall conform to specification IS:7280:1974.

5.0 STORING OF MATERIALS

5.1 Materials shall be stored and stacked properly ensuring that place is properly drained and is free from dirt. It shall be ensured that no damage is caused due to improper stacking.

6.0 MATERIAL PREPARATION

6.1 Cut edges shall be finished smooth by grinding or machining wherever necessary. Sufficient allowance (3 mm to 5 mm) should be kept in the items in case machining is necessary.

6.2 Cutting may be effected by gas cutting, shearing, cropping or sawing. In gas cutting of high tensile steel, special care is to be taken to leave sufficient metal to be removed by machining so that all metal that has been hardened by flame is removed.

6.3 Sufficient shrinkage allowance (@ 1mm/M) shall be kept wherever heavy welding is involved.

6.4 Straightening and bending shall be done in cold condition as far as practicable.

6.5 If required, straightening and bending may be done by application of heat between 900° C and 1100° C. Cooling down of the heated item shall be done slowly.

7.0 DRILLING AND PUNCHING OF HOLES

7.1 Drilling and punching of holes for bolts shall be done as per IS:800:2007, unless otherwise specified by the purchaser.

7.2 Drifting of holes for bolts during assembly shall not cause enlargement of holes beyond permissible limit or damage the metal.

7.3 Holes for bolted connection should match well to permit easy entry of bolts. Gross mismatch of holes shall be avoided.

7.4 Permissible deviation in holes for mild steel bolts of normal accuracy and high strength bolts are given in the **ANNEXURE-A**.

8.0 ASSEMBLY FOR FABRICATION

8.1 Fabrication of all structural steelwork shall be in accordance with IS:800-2007 and in

TENDER NO: GGPL/KKD/C&P/CW/2523/VS

- conformity with various clauses of this specification, unless otherwise specified in the drawings.
- 8.2** Fabrication of structures shall preferably be taken up as per the sequence of erection.
- 8.3** All erection units shall bear erection mark no. and reference drg no. at a prominent location on the structures for easy identification at site.
- 8.4** Fabricated structures shall conform to tolerance as specified in this standard and in IS:7215-1974. In case of contradiction, tolerances specified in this standard shall prevail.
- 8.5** All the components of structures shall be free from twist, bend, damage etc,
- 8.6** Assembly of structures shall be carried out by using suitable jigs and fixtures in order to obviate distortion during welding.
- 8.7** Cutting of items specially for truss, bracing, bunker, hopper, galleries surge girder, portal etc, shall be done only after checking of sizes as per Layout.
- 8.8** Surface, wherever machining is specified , shall be either planed or milled or ground to ensure maximum contact.
- 8.9** If end-milling or machining is planned after the assembly is over, sufficient allowance (5 mm to 15 mm) shall be kept in the items where milling/machining is to be done.
- 8.10** If pre-bending of the plate is required to avoid welding distortion, it shall be done in cold condition.
- 8.11** If extra joints are required to be provided in column, crane girder etc, approval should be obtained from the purchaser. However, as general guidance following is suggested. Splice joints of column and crane girder shall of full strength butt weld and wherever possible shall be located at zones of minimum or substantially lesser stress.
- 8.12** Splice joints of flange and web should be staggered.
- 8.13** Sufficient trial assembly of fabricated components (despatch elements) shall be carried out in the fabrication works to control the accuracy of workmanship.
- 8.14** Where necessary, washers shall be tapered or otherwise suitably shaped to give the heads of nuts and bolts satisfactory bearing.
- 8.15** The threaded portion of each bolt shall project through the nut at least by two thread.
- 8.16** Tolerance of assembled components of structures is given in **ANNEXURE-B**.
- 8.17** Permissible deviations from designed (true) geometrical form of the despatch elements shall be in accordance with IS: 7215-1974

9.0 WELDING

9.1 The Contractor shall work out welding procedure for Purchaser's approval, considering the following factors :-

- (i) Specification and thickness of steel.
- (ii) Specification of electrode or/and base wire.
- (iii) Welding process (manual arc welding, submerged arc welding).
- (iv) Type of structures to be welded (thickness of components meeting at a joint).
- (v) Pre and post heating requirement.
- (vi) Preparation of fusion faces.
- (vii) Sequence of welding.
- (viii) Weather condition.
- (ix) Use of jigs and fixtures etc.
- (x) Type of non-destructive testing to be carried out.
- (xi) Inspection procedure to be followed
- (xii) Design requirements of the joints.

9.2 Welding of any load bearing structure shall be carried out only by the person who has passed welder's qualification as per IS:7318 (Part-I)-1974.

9.3 All metal arc welding shall be carried out as per IS:9595-1996.

9.4 Submerged arc welding of mild steel and low alloy steel shall be as per IS:4353-1995.

9.5 Electrode shall conform to IS 814: 2004

9.6 Electrodes shall be stored in a dry place. Electrodes whose coatings are damaged due to absorption of moisture or due any other reason shall not be used.

9.7 Low Hydrogen electrodes and flux for submerged welding shall be dried as per manufacturer's recommendation at 250-300 Degree C for one hour in drying oven before use.

9.8 For suitability of wire flux combination, procedure test shall be carried out as per IS:3613-1974 if so required.

TENDER NO: GGPL/KKD/C&P/CW/2523/VS

- 9.9** Welding shall be done by electric arc process. Generally submerged arc, automatic & Semi-automatic welding shall be employed. Only where it is not practicable, manual arc welding may be resorted to. In case of manual arc welding, recommendations of electrode manufacturer is to be strictly followed.
- 9.10** Welding surface shall be smooth, uniform, free from fins, tears notches or any other defect which may adversely affect welding.
- 9.11** For multi-run weld deposit, the next run should be done only after thorough removal of slag and proper cleaning of surface.
- 9.12** Fillet weld shall have the correct profile with smooth transition into parent metal. Dressing of welds, if specified, shall be done by such method which does not cause grooving and other surface defects on the weld or on the parent metal.
- 9.13** All butt welds shall start and end with run-on and run-off plates. All such plates shall be carefully trimmed off by gas cutting after welding is over.
- 9.14** Fillet welds shall not be stopped at corners but shall be returned round them.
- 9.15** If butt weld is to be ground flush with the surface of the member as per drawing, adequate reinforcement shall be built up and then the same shall be chipped off and ground flush. The grinding is to be done in the direction of stress flow till the transverse marks are eliminated.
- 9.16** Welding shall not be done under such weather conditions which might adversely affect the efficiency of the welding.
- 9.17** Manipulators shall be used wherever necessary and shall be designed to facilitate welding and ensure that all welds are easily accessible to the operators.
- 9.18** Stress relieving after welding shall be done if especially called for in the drawing or specification. Ends of structural members and portions of gussets receiving welding at site shall be left unpainted.
- 9.19** Permissible deviation in assembly of weld joints shall be in accordance with **ANNEXURE - C**.
- 10.0 INSPECTION & TESTING**
- 10.1** The purchaser/Inspector shall have free access at all times to those parts of Contractor's or his Sub- Contractor's works which are concerned with the fabrication of steel works and shall be afforded all reasonable facilities at all stages of preparation, fabrication and trial assemblies for satisfying himself that the fabrication is being undertaken in accordance with the provisions of relevant specification.

TENDER NO: GGPL/KKD/C&P/CW/2523/VS

- 10.2** All gauges and templates, tools, apparatus, labour and assistance for checking shall be supplied by the contractor free of charge. The purchaser /Inspector may at his discretion, check the test results obtained at the Contractor's works, by independent test at the Government Test House or elsewhere, and should the material so tested be found to be unsatisfactory, the cost of such test shall be borne by the Contractor.
- 10.3** Contractor shall make all necessary arrangements for stage inspection by purchaser/Inspector during the fabrication at shop and incorporate all on-the-spot instructions / changes conveyed in writing to the Contractor.
- 10.4** Material improperly detailed or wrongly fabricated shall be reported to the Purchaser/Inspector and shall be made good as directed. Minor misfits which can be remedied by moderate use of drift pins, and moderate amount of reaming and slight chipping may be corrected in that manner, if in the opinion of the Purchaser/Inspector the strength or appearance of the structure will not be adversely affected. In the event the Purchaser/Inspector directs otherwise, the items will be rejected and a completely new piece shall be fabricated. The cost of correcting errors shall be to the account of the Contractor.
- 10.5**
- i) The Purchaser/Engineer shall have the power:
 - a) To certify, before any structure is submitted for inspection, that the same is not in accordance with the contract, owing to the adoption of any unsatisfactory method of fabrication.
 - b) To reject any structure as not being in accordance with specifications & drawings.
 - c) To insist that no structure or parts of the structure once rejected is resubmitted for inspection/test, except in cases where the Purchaser / Inspector authorised representative considers the defects as rectifiable.
 - ii) If, on rejection of structure by the Purchaser/Inspector the Contractor fails to make satisfactory progress within the stipulated period, the Purchaser/Inspector shall be at liberty to cancel the contract and fabricate or authorize the fabrication of the structures at any other place he chooses, at the risk and cost of the Contractor, without prejudice to any action being taken in addition to terms of General Conditions of Contract.
 - iii) The Purchaser / Inspector's decision regarding rejection shall be final and binding on the Contractor.
 - iv) The specifications prescribe various tests at specified intervals for ascertaining the quality of the work done. If the tests prove unsatisfactory, Purchaser/Inspector shall have liberty to order the Contractor to re-do the work, done in that period and/ or to

order such alterations and strengthening that may be necessary at the cost of the Contractor and the contractor shall be bound to carry out such orders failing which the rectification/redoing will be done by the Purchaser through other agencies and the cost recovered from the Contractor.

- v) Notwithstanding any inspection at the workshop the Purchaser/Inspector shall have the liberty to reject, without being liable for compensation any fabricated members or materials brought to site that do not conform to specifications / drawings.
- vi) All rejected materials shall be removed from the site of fabrication by the Contractor at his own cost and within the time stipulated by the Purchaser/Inspector.

11.0 CONTROL IN WELDING

Before inspection, the surface of weld metal shall be cleaned of all slag, spatter matter, scales etc. by using wire brush or chisel.

b) Dye Penetration Test (DPT)

This shall be carried out for all important fillet welds and groove welds as desired by purchaser for both statically and dynamically loaded structures to check the following :

- i) Surface cracks
- ii) Surface porosities

Dye Penetration Test shall be carried out in accordance with American National Standard ASTM E165.

c) Ultrasonic testing

Ultrasonic test shall be conducted for all butt/groove welds and heat affected zone in dynamically loaded structures and for other important load bearing butt welds in statically loaded structures as desired by purchaser, to detect the following :

- i) Cracks
- ii) Lack of fusion
- iii) Slag inclusions
- iv) Gas porosity

Ultrasonic testing shall be carried out in accordance with American National Standard ANSI/AWS D1.1.

Before ultrasonic test is carried out, any surface irregularity like undercuts, sharp ridges etc. shall be rectified. Material surface to be used for scanning by probes must allow free movement of probes. For this purpose, surface shall be prepared to make it suitable for carrying out ultrasonic examination.

d) Radiographic Testing

(X-ray and Gamma-Ray Examination) :- This test shall be limited to 2% of length of butt/groove welds for welds made by manual or semi- automatic welding and 1 % of length of weld if made by automatic welding machines . The location and extent of weld to be tested by this method shall be decided by purchaser to detect the following defects:

-

11.1 The extent of quality control in respect of welds for structural elements for both statically and dynamically loaded structures shall be as follows and shall be conducted by the contractor at his own cost:-

a) Visual Examination - All welds shall be 100% visually inspected to check the following:

- i) Presence of undercuts
- ii) Visually identifiable surface cracks in both welds and base metals.
- iii) Unfilled craters
- iv) Improper weld profile and size
- v) Excessive reinforcement in weld
- vi) Surface porosity

Before inspection, the surface of weld metal shall be cleaned of all slag, spatter matter, scales etc. by using wire brush or chisel.

b) Dye Penetration Test (DPT)

This shall be carried out for all important fillet welds and groove welds as desired by purchaser for both statically and dynamically loaded structures to check the following :

- i) Surface cracks
- ii) Surface porosities

Dye Penetration Test shall be carried out in accordance with American National Standard ASTM E165.

c) Ultrasonic testing

Ultrasonic test shall be conducted for all butt/groove welds and heat affected zone in dynamically loaded structures and for other important load bearing butt welds in statically loaded structures as desired by purchaser, to detect the following :

- i) Cracks
- ii) Lack of fusion
- iii) Slag inclusions
- iv) Gas porosity

Ultrasonic testing shall be carried out in accordance with American National Standard ANSI/AWS D1.1.

Before ultrasonic test is carried out, any surface irregularity like undercuts, sharp ridges etc. shall be rectified. Material surface to be used for scanning by probes must allow free movement of probes. For this purpose, surface shall be prepared to make it suitable for carrying out ultrasonic examination.

d) Radiographic Testing

(X-ray and Gamma-Ray Examination) :- This test shall be limited to 2% of length of butt/groove welds for welds made by manual or semi- automatic welding and 1 % of length of weld if made by automatic welding machines . The location and extent of weld to be tested by this method shall be decided by purchaser to detect the following defects:

- i) Gas porosity
- ii) Slag inclusions
- iii) Lack of penetration
- iv) Lack of fusion
- v) Cracks

Radiographic testing shall be conducted in accordance with American National Standard ANSI/AWS D1.1

Any surface irregularity like undercuts, craters, pits etc. shall be removed before conducting radiographic test. The width of the radiographic film shall be width of the welded joint plus 20 mm on either side of the weld.

12.0 ACCEPTABLE LIMITS OF DEFECTS IN WELD

12.1 Limits of Acceptability of welding defects shall be as follows: -

- a) Visual inspection & Dye Penetration Test - The limits of acceptability of defects detected during visual inspection and Dye Penetration Test shall be in accordance with American National Standard ANSI/AWS D1.1 for statically as well as dynamically loaded structures.
- b) Ultrasonic Testing - The limits of acceptability of defects detected during ultrasonic testing shall be in accordance with American National Standard ANSI/AWS D1.1 for statically and dynamically loaded structures.
- c) Radiographic testing - The limits of acceptability of defects detected during Radiographic testing shall be in accordance with American National Standard ANSI/AWS D1.1 for statically and dynamically loaded structures

13.0 RECTIFICATION OF DEFECTS IN WELDS

13.1 In case of detection of defects in welds, the rectification of the same shall be done as follows :

- i) Al2l craters in the weld and breaks in the weld run shall be thoroughly filled with weld.
- ii) Undercuts, beyond acceptable limits, shall be repaired with dressing so as to provide smooth transition of weld to parent metal.
- iii) Welds with cracks and also welds with incomplete penetration, porosity, slag inclusion etc. exceeding permissible limits shall be rectified by removing the length of weld at the location of such defects plus 10 mm from both ends of defective weld, and shall be re-welded. Defective weld shall be removed by chipping hammer, gouging torch or grinding wheel. Care shall be taken not to damage the adjacent material.

14.0 COMPLETION DOCUMENTS

14.1 On completion of work, the Contractor shall submit to the Purchaser the following documents: -

- a) The technical documents according to which the work was carried out.
- b) Copies of the "As built" drawings showing thereon all additions and alterations made during the fabrication.
- c) Manufacturers test certificates

TENDER NO: GGPL/KKD/C&P/CW/2523/VS

- d) Certificates/documents on control checking
- e) Test of welds
- f) Inspection Certificates issued by Purchaser/Consultant for the material/structures.

15.0 In addition to provision of erection and transport equipments, the scope of work includes supply of tools and tackles, consumables, materials, labour and supervision and shall cover the following:

- a) Storing and stacking of all fabricated structural components/units/assemblies at site storage yards till the time of erection.
- b) Transportation of structures from storage yard to site of erection, including multiple handling, if required.
- c) All minor rectification / modifications such as :-
 - i) Removal of bends, kinks, twists etc. for parts damaged during transportation and handling.
 - ii) Reaming of holes which do not register or which are damaged, for use of next higher size bolt.
 - iii) Plug-welding and re-drilling of holes which do not register and which cannot be reamed for use of next higher size bolt.

Drilling of holes which are either not drilled at all or are drilled in incorrect position during fabrication.

- d) Fabrication of minor missing items as directed by the purchaser.
- e) Verification of the position of embedded anchor bolts and inserts w.r.t. line find levels, installed by others based on Geodetic Scheme / Bench mark / Reference co-ordinates to be furnished by the Purchaser.
- f) Assembly at site of steel Structural components wherever required, including temporary supports and staging.
- g) Marking arrangements for providing all facilities for
 - i) Conducting ultrasonic x-ray or gamma ray tests by reputed testing laboratories

TENDER NO: GGPL/KKD/C&P/CW/2523/VS

- ii) Making available test films / graphs, with reports / interpretation.
- h) Site Rectification of damaged portions of shop primer by cleaning and application touch-up paint.
- i) Erection of structures including making connections by bolts / High strength Friction Grip bolts/welding as per drawing.
- j) Alignment of all structures true to line, level plumbs and dimensions within specified limits of tolerance.
- k) Application at site after erection, required number of coats of primer and finishing paint as per specification and drawing.
- l) Rectification of structures as per Preliminary acceptance report and Final acceptance report.

SECTION 2 ERECTION OF STEEL STRUCTURE

16.0 ERECTION

16.1 General

16.1.1 Erection shall be carried out in accordance with IS:800:2007 and other relevant standards referred to therein.

16.1.2 For safe and accurate erection of structural steelwork, staging, temporary support, false-work etc. shall be erected as required.

16.1.3 The fabricated materials received at erection site shall be verified with respect of marking on the key plan/marketing plan or shipping list.

16.1.4 Any material found damaged or defective shall be stacked separately and the damaged or defective portions shall be painted in distinct colour for identification and the same shall be brought to the notice of the Purchaser.

16.2 Erection of Structures

16.2.1 Erection work shall be taken up after receipt of clearance from the purchaser.

16.2.2 For safety requirements during erection, provisions in IS:7205:1974, IS:7969:1975 and other relevant Indian standards shall be followed.

16.2.3 Erection shall be carried out with the help of maximum PMChanization possible.

16.2.4 Prior to commencement of erection, all the erection equipment ,tools, tackles, ropes etc. shall be tested for their load carrying capacity. Such tests may be repeated at intermediate stages also if considered necessary and frequent visual inspection shall be done of all vulnerable areas and components to detect damages or distress in the erection equipment, if any.

16.2.5 Following shall be taken care of during erection, whenever necessary:-

16.2.5.1 Temporary bracing, whenever required, shall be provided to sustain forces due to erection loads and equipment etc. Erected parts of the structures shall remain stable during all stages of erection when subjected to the action of wind, dead weight and erection forces etc. Specified sequence of erection of vertical and horizontal structural members shall be followed.

16.2.5.2 Erected members shall be held securely in place by bolts to take care of dead load, wind load and erection load.

TENDER NO: GGPL/KKD/C&P/CW/2523/VS

- 16.2.5.3 All connections shall achieve free expansion and contraction of structures wherever provided.
- 16.2.5.4 No final bolting or welding of joints shall be done until the structure has been properly aligned.
- 16.2.5.5 For positioning beams, columns and other steel members, the use of steel sledges is not permitted.
- 16.2.5.6 Instrumental checking of correctness of initial setting out of structures and adjustment of alignment shall be carried out in sequence and at different stages as required. The final leveling and alignment shall be carried out immediately after completion of each section of a building .
- 16.2.5.7 All structural members shall be erected with erection marks in the same relative position as shown in the appropriate erection and shop drawings.
- 16.2.5.8 The contractor shall design, manufacture, erect and provide false-work, staging temporary support etc. required for safe and accurate erection of structural steelwork and shall be fully responsible for the adequacy of the same.
- 16.2.5.9 The Contractor shall also provide facilities such as adequate temporary access ladders, gangways, tools & tackles, instruments etc.to purchaser for his inspection at any stage during erection.

17.0 ROOF AND SIDE CLADDING WITH PRE-COLOUR COATED GALVALUME TROUGHED STEEL SHEETS

- 17.1.1 The scope of work shall cover:
- a) Preparation of drawings showing layout and size of sheets used details of connections and flashings, bill of materials.
 - b) Roof & Side Pre- color coated galvalume troughed steel sheets ,flashings and like corner pieces, apron pieces, ridges etc, loading, transportation and supply at site, unloading, stacking & storing on skids, cutting and bending of sheets wherever required; drilling of holes all as per specification and drawings.
 - c) Supply , Loading, transportation, unloading and delivery of sheeting material to erection site.
 - d) Provision of all tools, tackles, equipment, labour supervision and services required for the satisfactory completion of the work specified herein and on the drawings.
 - f) Erection in position sheets for roofing, sides, erection of all flashings, fit-

TENDER NO: GGPL/KKD/C&P/CW/2523/VS

tings like ridges, valleys, gutters, corners, apron etc. at all locations all work as per drawings and specifications.

- g) Gutters with Down comers work shall be carried out in line with the drawings.

17.1.2 The roof sheet shall be of Galvalume/zincalume BHP steel sheet made of cold rolled steel of 550 MPA minimum yield strength conforming to ASTM A366 or AS 1595. Base metal thickness shall be 0.5mm and total thickness of colour coated profiled sheet shall be 0.58mm.

17.1.3 Linear Metal False Ceiling :

- a) Providing, cutting, fabrication and installation of canopy false ceiling with TRAC 150 F of Interarch (or equivalent) coil coated (Pre-painted) steel false ceiling system comprising of 150 mm wide x 17 mm deep roll formed out of 0.50 mm thick polyester coated galvanized steel panels, fixed on steel runner of 34.5 mm width x 48 mm deep manufactured out of 0.60 mm thick pre-coated galvanized steel with rigid suspension of 20x20x0.5 mm fixed with steel brackets/clips etc. The suspension system should be meant of exterior use. The carrier shall be suspended at 1mtr c/c supported from purlin and suspension angle at 500 mm c/c. panel shall be factory cut to provide minimum joints. The longitudinal joints shall have additional special G.I. Splice in between two panels. The carrier joint shall have a carrier splice maintaining a module of 150 mm. The ceiling shall be clipped on to the suspended carriers after they are aligned and leveled. Cutting for fixing of light fittings shall be done as per the cutout required to fit the fixture. The work shall be carried out under a specialized and experienced supervisor. shall be humidity resistance, Fireproof, Moisture-Proof, Mould-Proof, Smoke-Proof, Sound-Absorbing product Metal ceiling panels shall be coil coated steel or Aluminum alloy of thickness 0.5 to 0.7MM
- b) Providing cut out in the false ceiling for the under lights as required. The under lights and wiring for the canopy, sinages shall be payable as per electrical SOR and Technical specifications.

Technical details

Size –150F

Thickness: 0.5 to 0.9MM

Sound Absorption (NRC): 0.60-0.70 Sound attenuation (dB): 28-34 Humidity

Resistance (%RH): 100 Fire Reaction: Class A (ASTM E84) Fire proof

Light Reflectance (%): 83-85

Panels are coil coated steel or Aluminum alloy

18.0 RULES & REGULATIONS OF SAFETY, ELECTRICITY BOARDS, FACTORY ETC.

18.1 The Contractor shall at all times comply with all relevant factory acts, electricity rules, safety regulations etc. as per statutory regulations of Central / State Government.

19.0 DEVIATIONS

19.1 Should the Contractor wish to deviate from any specification or details shown on the purchaser's approved drawings and / or Technical Specifications, he shall obtain the purchaser's written authority before proceeding with the deviations.

20.0 MEASUREMENTS

20.1 Structural Steel

Structural steelwork will be measured by the metric tonne and as per IS: 1200 (part-8) - 1993 and IS: 1200 (part-9) -1973 subject to provisions outlined below:-

- a) The calculation of quantities shall be based on unit weights for structural sections as given in IS: 808-1989 . The payments will be made on the basis of weights of members given in the approved fabrication drawings. However, any changes on the above weights during fabrication erection, payment shall be based on sketches Approved by the purchaser.
- b) In the event the I.S. does not specify any mode of measurement for a particular item of work, the same shall be measured as per any other relevant international standard or as directed by the Purchaser.
- c) The weight of all plates and sections shall be calculated from the approved drawing using the minimum overall square or rectangular dimensions and theoretical weight, no deduction being made for skew cuts, holes etc. In the case of plates, other than gussets, the actual dimensions shown on approved drawings will apply unless approved otherwise by the purchaser based on cutting diagram of mother plates.
- d) The weight of all welding runs, bolt, stanchion base packing, cuttings to waste and rolling margins, and coatings of paint, will be excluded from the measured weight and shall be deemed to have been allowed for in the rates for structural steelworks quoted by the Contractor.
- e) Temporary works and all other materials not included in the permanent works shall be excluded from any measurement for payment.

21.0 SIGNAGE WORKS

21.1 Monolith tower(or Pylon)

TENDER NO: GGPL/KKD/C&P/CW/2523/VS

- 21.1.1 4mm thick ACM (Aluminium Composite Material) panel router cut cladding on M.S. framework (hollow steel sections as per design requirement) with Product Panels of Retro Reflective Sheeting Type XI DG3 Microprismetice as per ASTM D 4956-09 in required colour & Size on both sides. Retro Reflective shall be of appropriate approved colour and cutouts for product names, logos, etc. duly CNC Plotted. The body of the monolith shall be in ACM having Total Thickness of 4mm : Top Coil 0.5mm (3003/3105 Grade as per IS - 737 1986 with minimum 25 microns PVdF Coating on top coil and Polyester / Epoxy coating on Back Coil (4 -7 microns PVDF ACM in colour and shape as per approved design.

The company logo should be prepared in polycarbonate sheets (GE/ LEXAN make) in corporate colours and thermoformed to form the design which shall be in turn fixed in cutouts made in monolith body of ACM. The portions of the monolith to be backlit to make the acrylic/ polycarbonate portions/ logos visible at night. Special spot lights (2 nos.- 400 watts with metal halide lights of Philips make) to be incorporated in design to light up the entire tower with throw from base. The backlit portion of the monolith to be lit with sufficient numbers T5 (28 W) tube lights (Philips make) with electronic choke, mounted on MS tube frames with plastic holders. Multi-strand copper conductors with PVC insulation to be used. Steel structural frame to be installed on RCC foundations. Top and exposed sides of the foundation to be cladded in 18 mm thick black polished granite. All work to be done in line, level and plumb, all complete with by works, as approved.

21.2 Canopy Fascia (1000mm wide) on canopy vertical faces

- 21.2.1 4mm thick ACM (of approved make) cladding in a combination of corporate colours with the use of Retro Reflective Sheeting Type XI DG3 Microprismetice duly pasted on ACM in required size & shape (colour scheme and design to be approved) on mild steel framework with part backlit for company logo and name. The letters shall be in 30 mm thick Acrylic/ PC duly CNC Routed in require shape & Size as per direction of concerned engineer. Structural frame to be welded rigidly/ Bolted to the structural member of existing canopy structures. Canopy fascia to be made in 12 m. (min.) long straight panels factory plan/processed at converters factory and assembled/installed at site. Corner piece (1 metre both sides) on both sides (as required), also to be factory plan/processed/assembled and installed at site. Only bottom trim and top flashing is to be Plan/processed and installed at site. All work to be done in line, level and plumb.

Backlit section of the fascia shall be of 4 meters length and one/ two logos (depending on design) and shall have sufficient number of LED/T5 (28 W) tube light with electronic chokes mounted with plastic holders to structural frame. The top of the fascia shall have 4 mm thick ACM with hinged GI service door in backlit part. The back of the fascia to have 18 gauge GI sheets. Multi-strand copper conductors with PVC insulation to be used. The bottom and top of the fascia shall have a white ACM trim to cover the gap between the canopy and fascia. The backside will be non-lit. the contractor should

make suitable fixing arrangement, which should be duly vetted by a certified structural engineer as per the actual dimensions of the canopy structure. The canopy fascia shall have a combination of approximately 200 wide ACM on the top and 700 wide below in proper approved design and colour scheme, complete with all by works

21.3 Building Fascia, 700mm wide on top of building faces in Elevation

- 21.3.1 4mm thick ACM (of approved make) cladding in a combination of corporate colours with the use of Retro Reflective Sheeting Type XI DG3 Microprismetice as per ASTM D 4956-09 duly pasted on ACM in required size & shape (colour scheme to be approved) on mild steel framework.

Structural frame to be fasteners/ Nut Bolted to the building walls with dash fasteners and leveling 'arrangement. Building fascia to be made in maximum length of straight panels (with minimum no. of joints) straight panels factory plan/processed at converters factory and assembled/installed at site. Corner piece (1 metre both sides) on both sides, also to be factory plan/processed/assembled and installed at site. Only bottom trim and top flashing is to be Plan/processed and installed at site. All work to be done in line, level and plumb, all complete with by works, as approved.

21.4 Spreader, 1200X450X150mm

- 21.4.1 4mm thick ACM (Aluminium Composite Material) cladding with the use of Retro Reflective Sheeting Type XI DG3 Microprismetice as per ASTM D 4956-09 duly pasted on ACM in required size & shape on structural framework with back-lit panels in 10 mm thick Acrylic/ PC duly CNC Routed in require shape & Size as per direction of concerned engineer. Front face of panels to have appropriate colour with cutout for text as indicated in drawings as approved and the sides to be white. Spreader frame to be fixed securely to canopy columns with box & cap arrangement. The spreader to be made in two sections as per design with 'L' lock. The smaller section to be mounted on sliding channel with sufficient no. of LED/ CFL lights and electronic chokes fixed with plastic holders. Multi-strand copper conductors with PVC insulation to be used. All work to be done in line, level and plumb, all complete with by works, as approved.

21.5 Mandatory sign, 300X750mm(on column), 300X450(on toilets)&300X600 (in compressor & LCV area)

- 21.5.1 4mm thick. ACM (Aluminum Composite Material) sheets cladded on structural framework. Matter/Logo in Retro Reflective Sheeting Type XI DG3 Microprismetice as per ASTM D 4956-09 duly pasted on ACM in required size & shape, all complete with by works, as approved.

300mm X 750mm 300mm X 450mm 300mm X 600mm

21.6 Direction sign

21.6.1 4mm thick. ACM (Aluminum Composite Material) cladding on steel framework with the use of 3M (or approved equivalent make) Retro Reflective Sheeting Type XI DG3 Microprismatic as per ASTM D 4956-09 duly pasted on ACM in require size & shap & back-lit panels in 10 mm thick Acrylic/ PC duly CNC Routed in require shape & Size as per direction of concerned engineer or 3 mm thick, thermoformed PET-G (Spectra Copolymer/ Relstar) on both sides. Front face of PET-G panels to have acrylic of appropriate colour with cutout for arrow sign as indicated in drawings and the sides to be white. The sign frame to be fixed securely to CC foundation as shown in drawings. The CC foundation shall have 8mm thick polished black granite tiles cladding on top and all exposed side surfaces. Sufficient no. of LED/ T5 (14 W) tube lights with electronic chokes fixed with plastic holders and electric connections. Multi-strand copper conductors with PVC insulation to be used. All work to be done in line, level and plumb, all complete with by works, as approved.

21.7 Canopy column cladding

21.7.1 Cladding in white 4mm thick ACM (Aluminum Composite Material) on structural with suspension pin, fixed securely to existing canopy column by welding at site. ACM panel fixing to ensure consistent joint gaps and panel size. All grooves shall be sealed with sealant material of approved colour, all complete with by works, as approved.

250mm X 500 mm 200mm X 400mm

a) Hoarding

Printed Flex sheet (make LG or 3M) with approved Art work (suitable for front lit) to be Fitted to the steel sheet of existing Hoarding structure in aluminium frame using Klick Rail System & as per direction of concerned Engineer/client.

b) Spot halogen lights

Supplying and fixing Spot halogen lights (150 watts of Philips make) at an interval of 2 m center to center on top of existing hoarding including supply with steel bracket and laying of cable upto electrical panel of Electrical room (in Utility building) complete in all respect.

SECTION-3 PAINTING OF STEEL STRUCTURES

22.0 SURFACE PREPARATION FOR PAINTING

22.1 General

The steel surface which is to be prepared shall be cleaned of dirt and grease and the heavier layers of rust by grinding prior to actual surface preparation to a specified grade.

22.2 Mechanical Cleaning

22.2.1 Manual/power tool cleaning.

Manual/power tool cleaning shall be done as per grade St-2 or St-3, of Swedish Standard Institution SIS 055900.

- i) Grade St-2: Thorough scraping and wire brushing, machine brushing, grinding etc. This grade of preparation shall remove loose mill scale, rust and foreign matter. Finally the surface is to be cleaned with a vacuum cleaner or with clean compressed air or with clean brush. After preparation, the surface should have a faint metallic sheen. The appearance shall correspond to the prints designated St-2.
- ii) Grade St-3: very thorough scraping and wire brushing, machine brushing, grinding etc. The surface preparation is same as for grade St-2 but to be done much more thoroughly. After preparing the surface, it should have a pronounced metallic sheen and correspond to the prints designated St-3.

23.0 PAINTS AND PAINTING

23.1 For use of specific painting system, the paint manufacturer's specification shall prevail.

23.2 General compatibility between primer and finishing paints shall be established through the paint manufacturer supplying the paints.

23.3 Before buying the paint in bulk, it is recommended to obtain sample of paint and establish "Control Area of Painting". On control area surface preparation and painting shall be carried out in the presence of manufacturer of paint.

23.4 In order to ensure that the supplied paint meets the stipulation in design drawing/ specification, if required, samples of paint shall be tested in laboratories to establish quality of paint with respect to (i) Viscosity (ii) adhesion/ bond of paint in steel surfaces (iii) adhesion/simulated salt spray test (iv) chemical analysis (percentage of solids by weight) (v) normal wear resistance as encountered during handling & erection (vi) resistance against exposure to acid fumes etc.

23.5 Whole quantity of paint for a particular system of paint shall be obtained from the same manufacturer.

TENDER NO: GGPL/KKD/C&P/CW/2523/VS

- 23.6** Thinners, wherever used, shall be as per recommendation of the paint manufacturer.
- 23.7** Areas which become inaccessible after assembly of structures shall be painted before assembly, after cleaning the surfaces as specified.
- 23.8** Wherever shop primer painting is scratched, abraded or damaged, the surfaces shall be thoroughly cleaned using emery paper and power driven wire brush wherever warranted, and touched up with corresponding primer. Touching up paint shall be matched and blended to eliminate conspicuous marks.
- 23.9** If more than 50% of the painted surface of an item requires repair, the entire item shall be Mechanically cleaned and new primer coats shall be applied followed by finishing coats as per painting specification.
- All field welded areas on shop painted item shall be Mechanically cleaned (including the weld area proper, adjacent areas contaminated by weld spatter or fumes and areas where existing primer. intermediate / finishing paint is burnt). Subsequently, new primer and finishing coats of paint shall be applied as per painting specification.
- 23.10** Application of paint shall be by spraying or brushing as per IS:487-1985 and in uniform layers of 50% overlapping strokes. Painting shall not be done when the temperature is less than 5 °C or relative humidity more than 85%, unless manufacturer's recommendations permit. Also painting shall not be done in frosty or foggy weather. During application, paint agitation must be provided wherever such agitation is recommended by the manufacturer.
- 23.11** Paint shall be applied at manufacturer's recommended rates. The number of coats shall be such that the minimum dry film thickness (DFT) specified is achieved. The dry film thickness of painted surfaces shall be checked with ELCOMETER or measuring gauges to ensure application of specified DFT.
- 23.12** All structures shall receive appropriate number of primer and finishing coats in order to achieve overall DFT as per design drawings/ specifications. First coat of primer paint shall be applied not later than 2-3 hours after preparation of surface, unless specified otherwise.
- 23.13** The finishing paint as specified shall be of approved colour and quality. The under coat shall have different tint to distinguish the same from the finishing coat.
- 23.14** Edges, corners, crevices, depressions, joints and welds shall receive special attention to ensure that they receive painting coats of the required thickness.
- 23.15** Machine-finished surface shall be coated with white lead and tallow before shipment or before being put into the open air.
- 23.16** Parts of surfaces embedded in concrete shall be thoroughly cleaned of grease, rust, mill scale etc. and shall be given a protective coat of portland cement slurry immediately af-

ter fabrication. No paint shall be applied on this part.

23.17 Zinc-rich primer paints, which have been exposed several months before finishing coat is applied, shall be washed down thoroughly to remove soluble zinc salt deposits. In similar circumstances, the surfaces of paint based on epoxy resin should be abraded or lightly blast cleaned to ensure adhesion of next coat.

23.18 Surfaces which cannot be painted but require protection shall be given a coat of rust inhibitive grease according to IS:958-2000 or equivalent international standard.

24.0 PAINTING SYSTEM

The recommended painting system for general service requirement of steel structures Refer **ANNEXURE-E**.

TENDER NO: GGPL/KKD/C&P/CW/2523/VS

ANNEXURE-A

Permissible deviations in pitch and gauge of holes for bolts of normal accuracy (high strength bolts included)

Description	Hole diameter (mm)	Permissible Deviations in Spacing (mm)	Permissible deviations in each group of holes	
			Carbon Steel 4	Low Al-loyed Steel 5
1	2	3		
a) Deviation in the hole diameter.	Upto 17.0 Above 17.0	+1 +1.5	No limits	
b) Ovality (difference between the biggest and the smallest diameter)	Upto 17.0; Above 17.0;	+1 +1.5	No limits	
c) Curves, exceeding 1mm and cracks on the hole edges	–	–	Not Permissible	
d) (i) Non-coincidence of holes in separate details of the assembled unit, upto 1mm	–	–	Upto 50%	Upto 50%
(ii) Above 1 mm upto 1.5 mm	–	–	Upto 10%	Upto 10%
e) Slope of axis	–	Upto 30% of the thickness of unit	No limits	No limits

TENDER NO: GGPL/KKD/C&P/CW/2523/VS
ANNEXURE –B
TOLERANCE OF ASSEMBLED COMPONENTS OF STRUCTURES

 Description of Deviation (\pm) in mm for the Elements of Structures Components of Length in Metres

Structures	Up to 1	1 to 5	5 to 10	10 to 15	15 to 20	20 to 25	Over 25
1	2	3	4	5	6	7	8
I.i) Deviations from the dimensions assembled. Length & width of the Details Cut :							
a) Manual gas Cutting as per marking	3	3.5	4	4.5	5	-	-
b) With shears or with a saw as per marking	2	2.5	3	3.5	4	-	-
c) With shears or with a saw with a stop	1.5	2	2.5	3	3.5	-	-
d) Machine Gas Cutting	2	2.5	3	3.5	4	-	-
ii) Length and width of planed ends processed on Edge Planing Machine	1	1.5	2	2.5	3	-	-
II i) Distance between the Centres of the End holes.							
a) Drilled according to marking	2	2.5	3	3.5	4	-	-
b) Drilled according to a gauge with bushing	1	1.5	2	2.5	3	-	-
ii) Distance between the centres of adjacent holes							
a) Drilled according to marking or to a gauge	1.5	-	-	-	-	-	-
b) Drilled according to a gauge with bushings	0.5	-	-	-	-	-	-
III. Deviation in the dimensions of despatch elements after completion of fabrication, Assembled in positioners or in other Devices with clamps in fixed positioners and also							
a) According to guide blocks with pins.	2	3	5	7	8	9	10
b) Assembled with bolts	3	5	8	11	12	14	15
c) Size (length & width) between Milled surface (for all cases of assembly)	1	1.5	2	2.5	3	3.5	4
d) The same made in separate details during machining & fixed during the assembling work with clamps	2	3	5	7	8	9	10
e) The same drilled according to positioners in finished structures	1	1.5	2	2.5	3	3.5	4

ANNEXURE – C
PERMISSIBLE DEVIATION IN ASSEMBLY OF WELDED JOINTS:

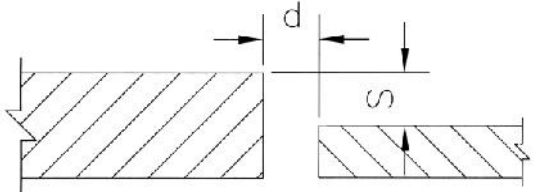
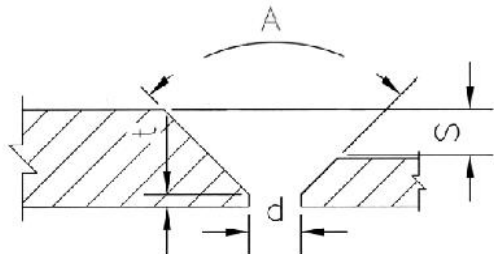
Description	Permissible deviation	Sketch
A. Square-butt Joints: a) Gap between the ends of plates (d) b) Stepping of one plate over the other (s)	 $\pm 1 \text{ mm}$ 1 mm	
B. Single Vee-groove Joints (without backing strip) a) Bevel angle (A°) b) Gap between two Plates (d) c) Stepping of one plate over the other (s) d) Root thickness (t)	 $\pm 5^\circ$ $\pm 1 \text{ mm}$ 2 mm 1 mm	
C. Double V-groove Joint Stepping of one plate over the others (s) a) plate over the others (s) b) Deviation in the value of Root thickness (t) c) Deviation in Bevel angle (A°) d) Deviation in value of Gap (d)	 2 mm 1 mm $\pm 5^\circ$ $\pm 1 \text{ mm}$	
D. Lap Joints:		

TENDER NO: GGPL/KKD/C&P/CW/2523/VS

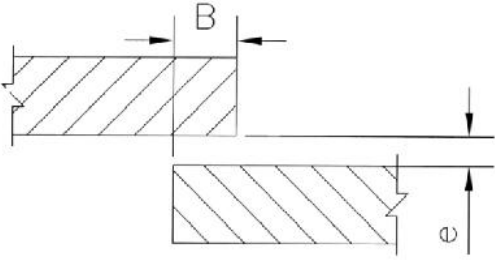
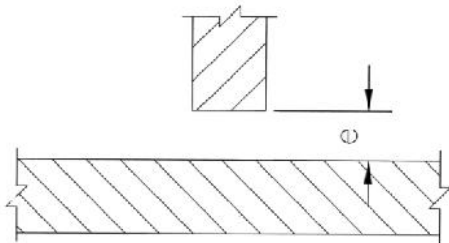
	<p>a) Overlap (B)</p>	<p>5 mm</p>	
	<p>b) Gap between the surfaces (e)</p>	<p>1 mm</p>	
<p>E.</p>	<p>Tee fillet Joints: a) gap between the edge of the web and the surface of the flange(e)</p>		

ANNEXURE – D
TOLERANCES IN ERECTED STEEL STRUCTURES

Sl No.	Description	Tolerance (mm)
A.	COLUMNS	
1.	Deviation of column axes at foundation top level with respect to true axes.	
	i) In Longitudinal direction	± 5
	ii) In Lateral direction	± 5
2.	Deviation in the level of bearing surface of columns at foundation top with respect to true level	± 5
3.	Out of plumbness (verticality) of column axis from true vertical axis and measured at column top :	
	a) For columns without any special requirements :	
	i) Upto and including 30m	$\pm H/1000$ or ± 25 mm height whichever is less
	ii) Over 30 m height	$\pm H/1200$ Or ± 35 mm maximum
	b) For column with special requirements like cranes or such similar requirements :	
	i) Upto and including 30m	$\pm H/1000$ or ± 20 mm height whichever is less
	ii) Over 30 m height	$\pm H/1500$ or ± 25 mm maximum
4.	Deviation in straightness in longitudinal & transverse planes of columns, at any point along the height	$\pm H/1000$ or ± 10 mm whichever is less.
5.	Difference in the erected position of adjacent pairs of columns along length or across width of building, prior to connecting trusses / beams, with respect to true distance.	± 5
6.	Deviation in any bearing or seating level with respect to true level.	± 5
7.	Difference in bearing levels of a member on adjacent pair of columns both across and along the building, from the true difference.	± 5

NOTE :i) Tolerance specified under 3(a) and 3(b) should be read in conjunction with 4 and 5.

ii) "H" above is the column height in mm

B. TRUSSES

1.	Shift, at the centre of top chord member of truss with respect to the centre of span or vertical plane passing through the centre of bottom chord.	$\pm 1/250$ of height span in mm or ± 15 mm whichever is less
2.	Lateral shift of top chord at the centre of of truss span from the vertical plane passing through the centre of supports of the truss.	$\pm 1/1500$ of span of truss in mm or ± 10 mm whichever is less
3.	Lateral shift in location of truss from its true vertical position.	± 10
4.	Lateral shift in location of purlins from true position.	± 5
5.	Deviation in difference of bearing levels of trusses or beam from the true (L =span) difference.	L/1200 or 20 mm whichever is less
6.	Relative shift in the track location of crane stops (end buffers) along the crane tracks, along track	1/1000 of gauge S in mm subject to maximum of 20 mm gauge.

PAINTING SYSTEM

Enamel System :

- i) Primer Paint : Two coats of Zinc Phosphate in phenolic alkyd medium (DFT=40 microns/coat)
- ii) Intermediate Paint : One coat of Synthetic MIO(ie: micaceous iron oxide) (DFT=75 microns/coat)
- iii) Finishing paint : Two coats of Synthetic enamel (DFT=25 microns/coat) conforming to IS: 2932-2003

ANNEXURE - F

MATERIAL OF CONSTRUCTION (AS APPLICABLE)

1. Unless otherwise specified in the drawing:
 - a) All rolled sections and plates shall conform to Grade-A as per IS:2062-1999.
 - b) Plated structures subjected to dynamic loading shall conform to Grade-B as per IS: 2062-1999.
2. Steel sheets shall conform to IS:1079-1994.
3. Steel tubes for structural purposes shall conform to IS:1161 1998(Grade YST-240).
4. Collectors and down comers shall conform to IS:3589-2001.
5. All black hexagonal bolts, nuts and locknuts shall conform to IS:1363(Part 1 to 3 -2002 and IS:1364(Part 1 to 6)-2002(for precision and semi- precision hexagonal bolts). Washers shall conform to IS:5369-1975.
6. All HSEFG bolts shall conform to IS:3757-1985.
7. Covered electrodes for arc welding shall conform to IS:814- 1991. Coding of electrodes shall be as follows :-
 - a) ER 421 'C' x for mild steel of Grade A and Grade-B as per IS:2062-1999.
 - b) EB 542 'C' x H3X
for
 - i) Mild Steel of Grade B as per IS:2062-1999 for dynamically loaded structures (arising out of crane, vibratory screen, equipment etc.)
 - ii) For SAIL-MA micro alloyed steel 350 HYA/HYB.

TENDER NO: GGPL/KKD/C&P/CW/2523/VS

- iii) When combined thickness (CT) for steel conforming to IS:2062-1999 exceeds 40mm as per Fig.1
 "C" is the value of current as recommended by the electrode manufacturer.

STRUCTURAL AND CIVIL DRAWINGS

LIST OF STANDARD DRAWINGS (CIVIL AND STRUICUTURAL)

SI No.	Description	Document No./ Drawing No.	Rev. No.
1	TYPICAL DETAILS OF SS TUBE TRENCH	PMC/GGPL/G1/01/TD/1051	Rev. 0
2	TYPICAL DETAILS OF SOAK PIT & SEPTIC TANK	PMC/GGPL/G1/01/TD/1052	Rev. 0
3	TYPICAL DETAILS OF DISPENSER ISLAND	PMC/GGPL/G1/01/TD/1053	Rev. 0
4	DETAILS OF CHAIN LINK FENCING	PMC/GGPL/G1/01/TD/1054	Rev. 0
5	DETAILS OF BOUNDARY WALL	PMC/GGPL/G1/01/TD/1055	Rev. 0
6	TYPICAL DETAILS OF CANOPY –A (TWO LEGGED)	PMC/23QQ/01/12/D2/CN/ST/0301	Rev. 0
7	TYPICAL DETAILS OF CANOPY –A (FOUR LEGGED)	PMC/23QQ/01/12/D2/CN/ST/0302 3	Rev. 0

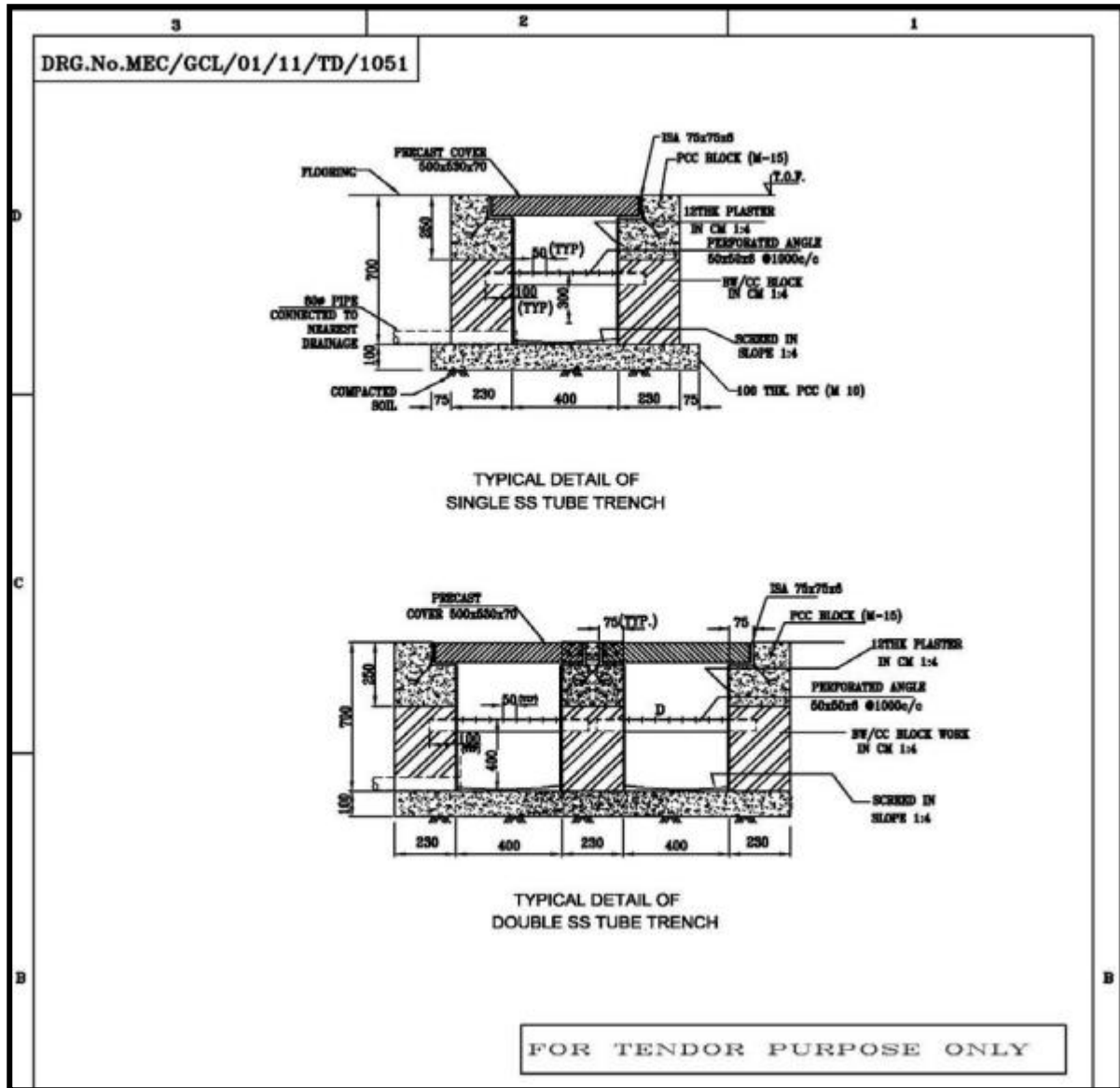

TENDER NO: GGPL/KKD/C&P/CW/2523/VS

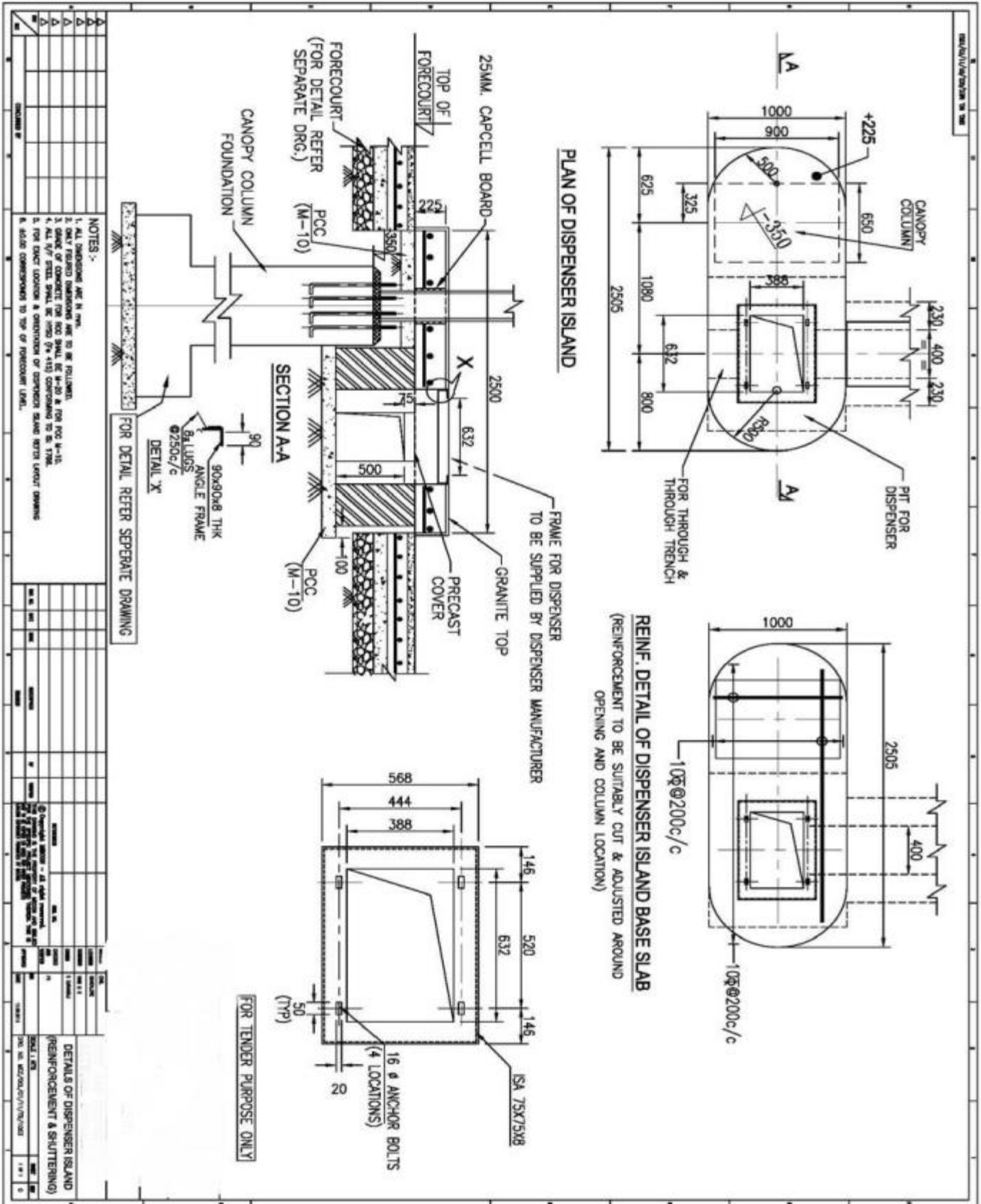

TENDER NO: GGPL/KKD/C&P/CW/2523/VS

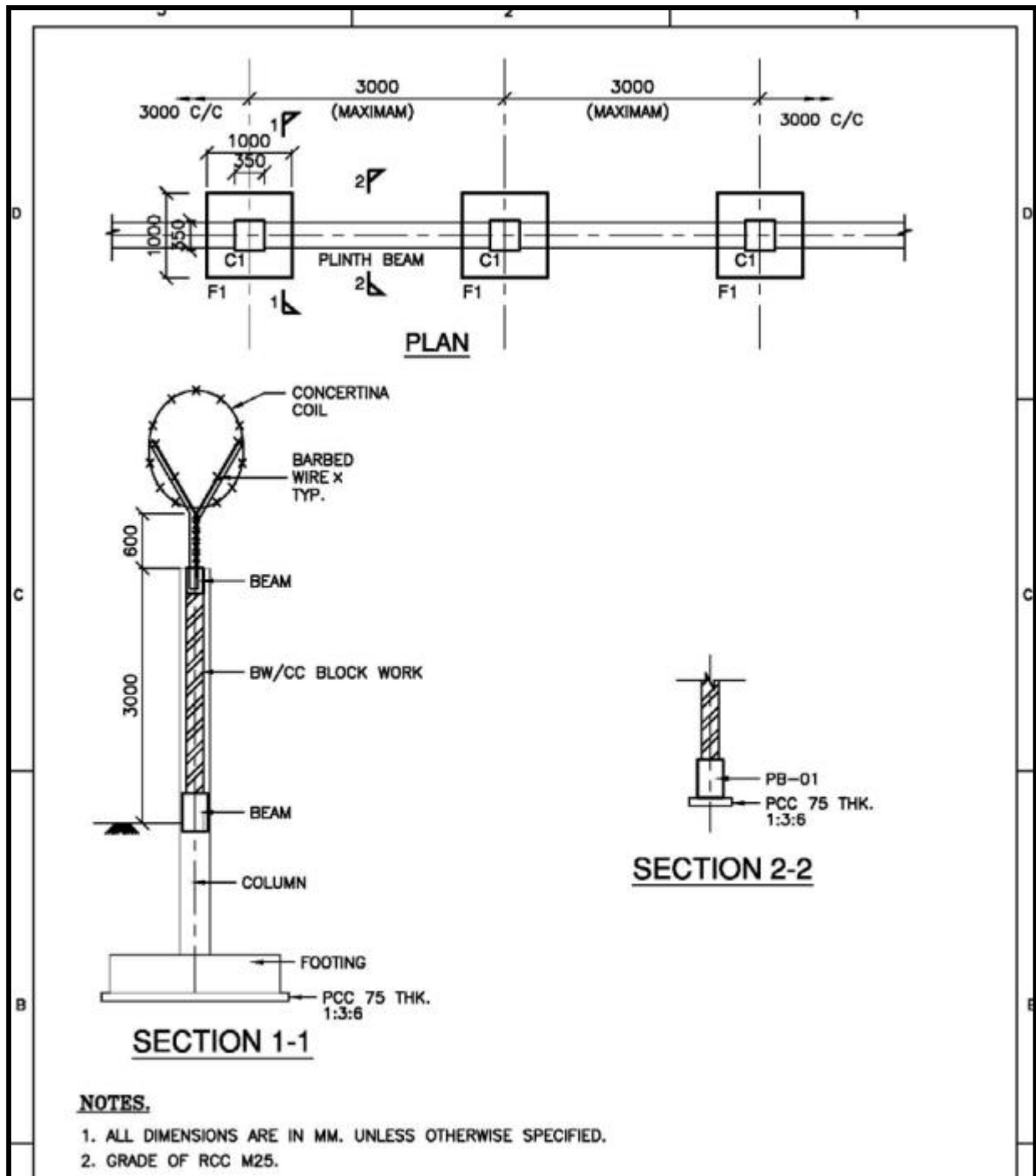

SCALE: 1:1000 UNLESS SPECIFIED OTHERWISE

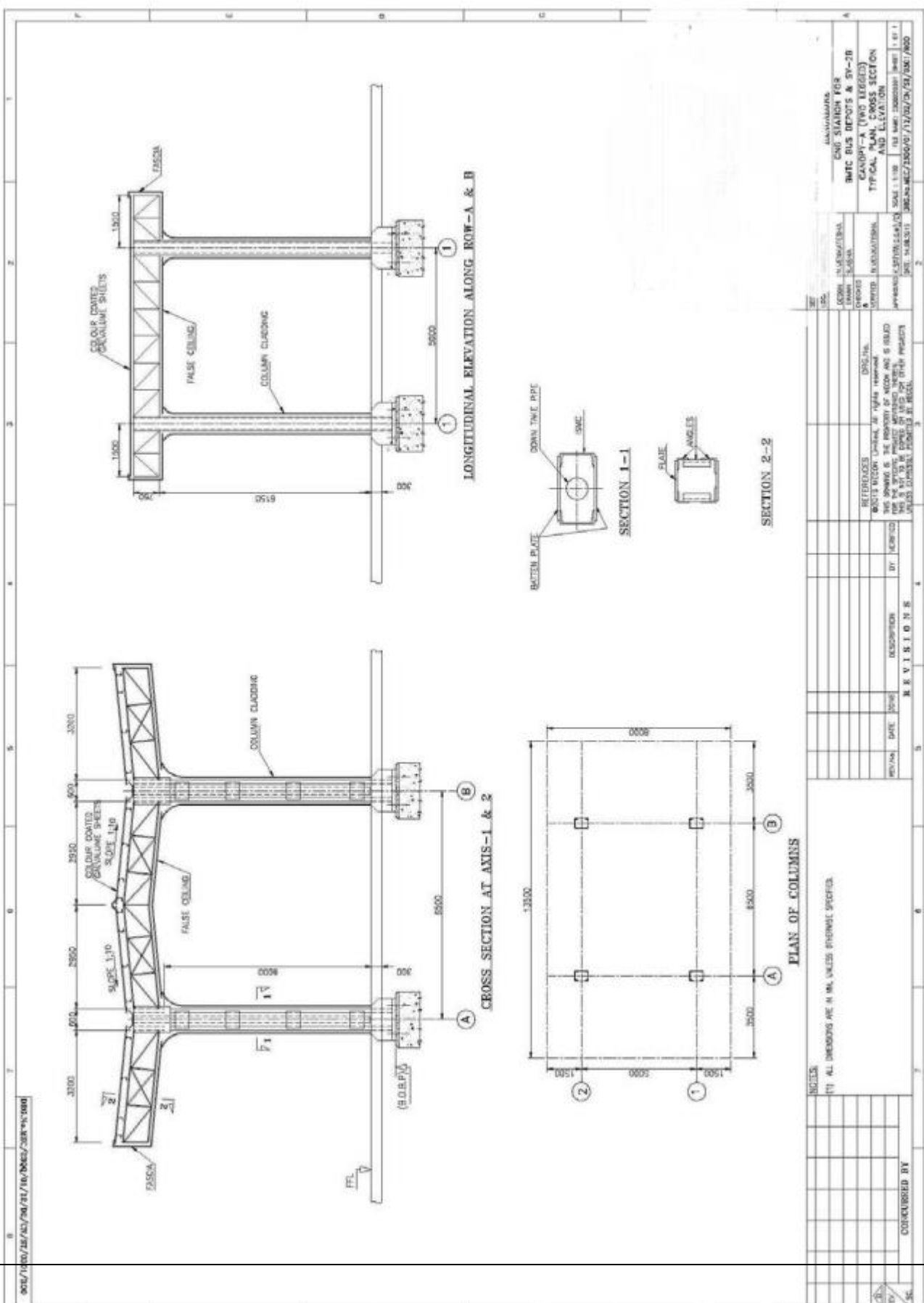

LONGITUDINAL ELEVATION ALONG ROW-A & B

CROSS SECTION AT AXIS-1 & 2

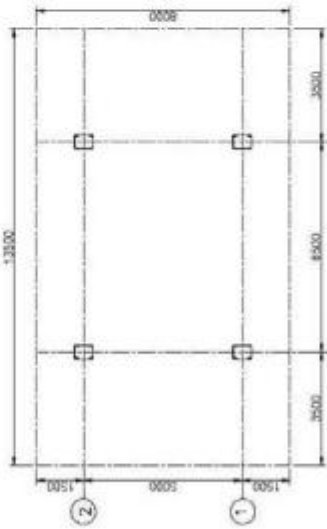
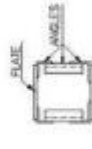
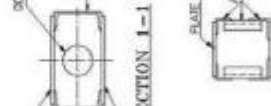

REV.	NO.	DESCRIPTION	DATE	BY	CHKD.

DESIGNED: _____ DRAWN: _____ CHECKED: _____ APPROVED: _____ DATE: 10/08/2018	PROJECT: _____ SHEET NO: _____ OF _____
--	---

NAME OF THE CONTRACTOR: _____ ADDRESS: _____ PHONE NO: _____ E-MAIL: _____	CONTRACT NO: _____ PROJECT NAME: _____ LOCATION: _____
---	--

PREPARED BY: _____ CHECKED BY: _____ DATE: _____	APPROVED BY: _____ DATE: _____
--	-----------------------------------

SCALE: 1:100 UNLESS SPECIFIED OTHERWISE

GGPL/KKD/C&P/CW/2523/VS

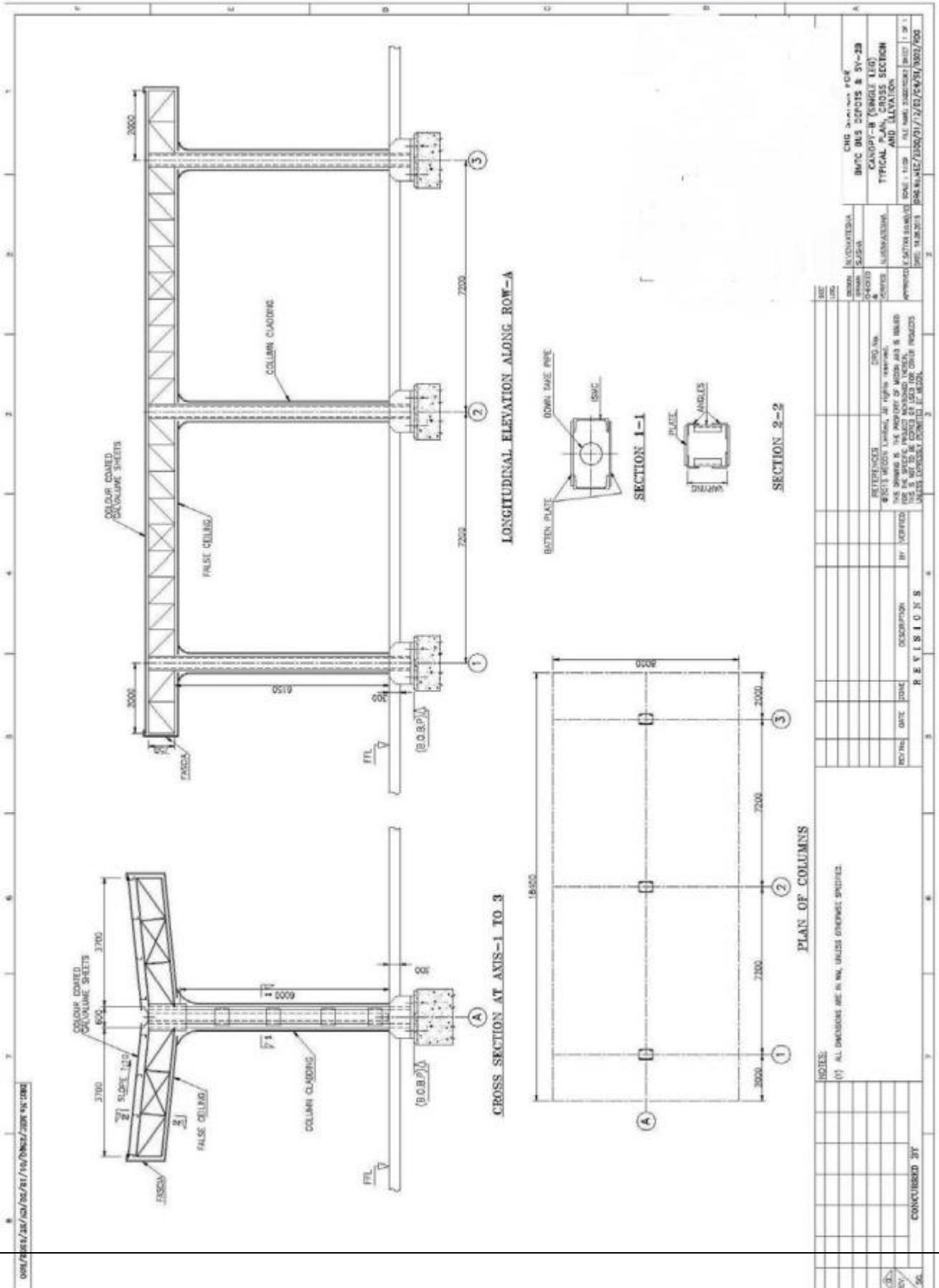

PART-II

ELECTRICAL & ILLUMINATION WORKS

PART – A – GENERAL ISTRUCTIONS

1.01 Introduction

The intent of this specification is to define the requirements for the supply of equipment and materials (as required), erection, testing and commissioning of the electrics and illumination power distribution system.

The work shall be carried out in the best workmanship - like manner, in conformity with these specifications, approved drawings and the instructions of the Engineer-in-charge from time to time.

The contract shall include clearing of temporary construction, waste materials and loose earth, which might get collected in and nearby the work site consequent of the execution of work under this contract.

1.02 Standards

The equipment to be supplied as well as the work being executed shall conform to applicable Indian Standards (BIS)/ recognized International Standards viz IEC/IEEE/VDE where corresponding Indian Standards do not exist , code of practices of the Bureau of India Standards, technical specifications and installation standards enclosed herewith In case of any conflict, the most stringent specification shall govern.

In addition, the work shall also conform to the requirements of the following: The Indian Electricity Act, and the Rules framed there under The fire Insurance Regulations

The regulations laid down by the Chief Electrical Inspector of the state government / Central Electricity Authority (CEA).

The regulations laid down by the Factory Inspector.

The regulations laid down by the Chief Inspector of Explosives.

Any other regulations laid down by the Central, State or Local Authorities from time to time during the pendency of this contract.

1.03 Site Condition

The equipment offered and the installation shall be suitable for continuous operation under the following site conditions.

Max. / Min temperature	:	46 ⁰ C/5 ⁰ C
Max. relative humidity	:	90 %
Altitude	:	Less than 500 m above MSL

1.04 Power Supply Parameters

NORMAL POWER	415V AC, 3 Phase & Neutral
LIGHTING DISTRIBUTION (Normal)	230 V AC, 1 Phase
INSTRUMENTATION (UPS)	230 V AC, 1 Phase

1.05 SCOPE OF WORK

Scope of work shall cover procurement, supply, loading, transportation, delivery, transit insurance, unloading, storage and handling at site, erection, insurance during erection till handing over, testing and commissioning of various equipment/systems/sub-systems of FRLS, 1.1kV Grade Copper LT Power cables, FLP Outdoor Illumination consisting of Street light poles, light fixtures, switches/sockets, FLP type Isolating switch, 63kVA 11/0.433kV, Distribution transformer, Earthing & lightning protection system including civil and structural works, conducting site Tests and trial runs of the above System, Watch and ward of the site till handing over to Owner, preliminary acceptance test (PAT), final acceptance test (FAT) and handing over the system in 'Ready to switch on' condition to the Owner, as described in the specification. The package shall be executed on **ITEM RATE BASIS** as per enclosed BOQ.

All equipments / materials supplied by the contractor shall be as per the list of approved makes enclosed with this document subject to submission of Certification and approvals.

Special Instructions to the Tenderer :

1. The scope of work shall include minor civil works related to the placement of panels/equipment being supplied by tenderer in electrical premises viz, chipping, grouting, making/closing, providing chequered plates for unused openings etc.
2. Tenderer shall coordinate and co-operate with Owner/ Owner's Consultant, other agencies engaged by the Owner for any data/information exchange, installation / erection, testing and commissioning of plant. The scope includes attending various co-ordination meetings/ progress review meetings, design review meetings etc.
3. The successful tenderer shall carefully go through the clause of Invitation to Tender, specification, Bill of Quantities and drawings and shall include in his rates any sum he may consider necessary to cover fulfillment of the various clauses contained therein. Unit prices stated in the Bill of Quantities against the item of work shall be inclusive of all installation accessories and consumables necessary to complete the said work within the contemplation of the contract. Beyond the unit prices no extra amount will be paid for incidental contingent work or materials.
4. For installation work at site, the successful tenderer shall be fully responsible for arranging the required handling equipment, winches, pulley, drilling machines, tools and tackles, welding sets, pipe bending machine, cable crimping tools, gauges, scaffoldings, ladders, temporary water and power connections, testing instruments etc as required for smooth execution of work.

TENDER NO: GGPL/KKD/C&P/CW/2523/VS

5. On completion of the installation but before energisation of the system, all installations shall be physically checked and properly tested. These checks and tests shall be conducted by the tenderer under the supervision of Owner/Consultant
.The tenderer shall furnish the final status and test results. Any defect observed during such check and tests shall be rectified by the tenderer free of cost within contract completion period.
6. The wastage limits for cables shall not be more than 2.5 % of total quantity of cables. Before cutting of cables from drums, the tenderer shall carry out measurement of cable required to be laid and the cable shall be cut from the drum as per drum cutting schedule to be prepared by him so that wastage is minimized.
7. The quantities given in Schedule of Quantities are probable quantities of work involved. These are furnished for the tenderer's conveniences and it must be clearly understood that the contract is not a lump sum contract, that the probable quantities and the aggregate value of the entire tender are only indicative and the OWNER does not in any way assure the tenderer or guarantee that the actual quantity of work would correspond to the probable quantities in the tender.
8. Cables shall be supplied in wooden cable drums and the minimum cable length in a drum shall generally not be less than 1000M. Tenderer shall note that variation of cable length in each cable drum shall not be more than + / - 5 % of total cable length for the cable drum. However, there shall not be any "negative" (-ve) tolerance in the quantity of cables for each size of cable.
9. Tender shall note that the cable jointing shall be avoided as far as possible, however if the requirement of cable joints is inevitable the same shall be done only after the approval from Owner / consultant at site.
10. The installation price for equipment and fittings shall include supply, fabrication and erection of painted supporting brackets made of steel angles, flats etc including bolts, nuts, washers etc., minor civil work and all consumable materials required for the installation. Suitable identification tags shall be provided without any extra cost to the OWNER.
11. Generally all floor mounted panels shall be tack welded to embedded channels and inserts provided in the floor. Where foundation pockets are not provided, and are required for fixing of equipment the tenderer shall provide adequate size of expansion type fasteners which shall be installed in the floor slab or brick wall by drilling as recommended. No additional rates shall be admissible on this account, whatsoever.
12. The tenderer shall include in his quoted installation price the supply of all necessary miscellaneous erection materials such as cable clamps, bolts, nuts, washers, shims, tapes etc as required to complete the installation of individual equipment and cables in all respect.
13. Installation price of cables/wires shall include supply and installation of all accesso-

TENDER NO: GGPL/KKD/C&P/CW/2523/VS

ries like glands, lock nuts, cable lugs and ferrules, bolts, nuts, screws, washers, identification tags etc and all other consumable materials as required. Also cost for transporting of cable drums, laying of cable, cutting of cables as per required length, returning surplus/cut length, sealing of pipes and holes including spare ones are included. Installation price of cables shall include laying of cables through pipes and pipe sleeves wherever required. Installation price for laying of cables in air shall include required consumables, clamps, providing aluminium cable tags at both ends at specified lengths including supply and punching of tags.

14. Installation price of pipes to be laid in ground required for cable laying, road / rail crossings shall include necessary cutting of road, excavation of required depth as per the drawings, Back filling, Laying, concrete embedment and subsequent repair and finishing the road as before.
15. Installation price of cables/wires shall include all the labour along with the rate for the services of joiner and labour, supervision, testing and cost of installation material such as identification tags, consumable material etc as required for completing the termination work in all respects. The rate for pulling of cables through conduits / pipes, laying inside covered cable trenches, laying on walls on saddles / Clamps, measurement at site prior to cutting of cable, cable ties, cable clamps, dressing of cables, providing cable tags at intervals and at exit / entry points of buildings, sealing of the conduit/pipes with cable putty, Cable markers shall be provided at every 10 meters for cable directly buried in ground. shall be included in the rates quoted for installation of cables. Installation price for cable trays shall also include the rates for coupler plates, Zinc passivated fasteners, clamps for fixing on cable tray supports etc in the rate quoted for the supply and installation of cable trays.
16. Installation price of directly buried underground cables shall include excavation of cable trench to a depth of 1000mm from finished ground level, providing at least 75mm sand cushion in the trench, laying of cable over the sand cushion, again providing 75mm sand cushion on the cable laid, placing burnt red bricks suitably over top layer of sand cushion and back filling of excavated trench with good soil. The installation charges of underground cabling shall include labour, supply & installation of above said materials viz., sand, burnt red bricks, good earth for back filling, cable route markers, joint markers etc.
17. The installation price of equipment like LDB, MCBDBs, MCB box, earthing, cables, wiring, lighting etc covered in the scope shall include floor openings/drilling/cuttings, provision of sleeves / inserts/ mounting channels wherever required, foundation bolts along with all civil materials for completion of installation in all respects for smooth and reliable operation. The installation rates shall also include supply and fabrication of steel materials including all miscellaneous accessories. Tenderer shall include the rates for minor civil works such as chipping/grouting, providing shim plates, tack welding to floor / wall embedded inserts, providing bolts/nuts for fastening to embedded bolts, welding of supports to column etc., in cost for the installation of switchboards along with the cost for embedment in concrete / supply of fabricated supports.
18. Installation prices of fan/exhaust fans, PVC conduits etc shall include supply and

TENDER NO: GGPL/KKD/C&P/CW/2523/VS

erection of supporting brackets, clamps, saddles, brackets, hooks, cleats including bolts, nuts, washers identification tags etc and other consumables as well as minor civil work involved for the installation.

19. Installation price of light fittings viz., FLP light fixtures, well glass/Road light fittings / low bay fluorescent / CFL / HPSV/LED light fittings shall include mounting of lighting fittings on structure/wall including mounting of control gear box by means of conduits of required length, MS angle / pipe, brackets, suspension hooks, straps, clamps, ball and socket, nuts, bolts and terminal boxes wherever required, cutting and making of required threads and supply steel materials, fabrication of brackets, interconnection between control gear box, bushing, locknuts etc. as required. Flexible cables as required for tapping to individual lighting fittings as well as 14 SWG GS wire for earthing and flexible conduits shall be included in the prices quoted for installation of lighting fittings. Supply of all materials and accessories shall be included in the installation price, Installation rates for road lighting fittings shall also include supply of steel materials, fabrication of brackets, interconnection between Control Gear box and fittings with supply of suitable clamps, lugs etc. Flexible conduits wherever required same shall be included in the installation rate of light fittings.
20. Installation price of point wiring includes cabling /wiring, installation of switchboards, modular type switches & universal socket outlet, junction boxes, ceiling roses along with 19mm dia Rigid PVC conduits. The point wiring shall also includes circular/rectangular thermoplastic material junction boxes, bends, tees, sockets, adapters, reducers etc and accessories such as saddles, distance pieces etc as per requirement for installation on walls / structure / ceiling.
21. Installation prices of earthing conductors along floor, wall, structures, etc shall include clamps, cleats and other fixing devices, jointing as well as termination including chipping of floors where required and making good the same after erection. The installation price of earthing strips laid buried in ground shall include excavation up to 800mm depth, laying, backfilling including clamps, cleats and other fixing devices , jointing as well as termination, bitumen paint at the joints of the earth strip . Also the installation price of earth station shall include excavation, dewatering, laying of pipes, providing supports, drilling, welding, hot boring, jointing with jointing materials, , fabrication, fixing of all fittings and accessories, wrapping and coating, construction of concrete enclosure with top cover and filling with salt and good earth complete with testing, painting the tested value together with station No. on aluminium marker plates and commissioning to ensure satisfactory earth resistance results.
22. The rates for fixing of supports by means of tack welding, grouting, anchor bolts etc as required as per site conditions shall be included in the rates quoted for installation of prefabricated galvanized cable tray support structures.
23. Submission of manufacturer's test reports of all equipment is in the scope of work of the tenderer.
24. Submission of documentation on safety and statutory measures.

TENDER NO: GGPL/KKD/C&P/CW/2523/VS

25. Any rework required to be done due to inadequacies in the work of tenderer and any reasons not attributable to Owner shall be done by the tenderer at no extra cost.

26. During site installation, testing and commissioning if any damages are caused by incorrect procedures of the successful tenderer such items to be repaired / replaced by tenderer free of cost within the time schedule for completion of work at no extra cost.

1.06 DRAWINGS, STANDARD SPECIFICATIONS AND INSTALLATION STANDARDS

- 1) The drawings accompanying the tender documents when read with specification shall depict the electrical system of the Terminal. These are indicative of the nature of work and issued for tendering purposes only. Purpose of these drawings is to enable the tenderer to make an offer in line with the requirements of the Owner. Construction shall be as per drawings / specifications issued / approved by the Engineer-in-charge during the course of execution of work.
- 2) Conduit layout drawing in ceiling, wherever required, to be prepared by the contractor and shall be submitted for approval.
- 3) After the job completion, contractor shall submit catalogues/manuals (O&M) of major brought out items. Final certified as built drawings, documents and manuals etc shall be submitted by the contractor to Owner in bound volume with one set in soft copy (CD) plus five sets of prints.

PART – B - EQUIPMENT SPECIFICATIONS (To be read always in conjunction with Design Basis as stated in Part – A above)

1. TRANSFORMERS

1.1. General

- 1.1.1. The distribution transformer will be connected to supply system to step down the supply voltage to feed 415V substations.

1.2. Transformer rating and over loading

Transformers shall be capable of delivering the rated current at a voltage equal to 112.5 percent of the rated voltage without exceeding the temperature limits specified for liquid, winding and hot spot

Transformers shall operate satisfactorily without injurious heating at rated kVA, at any voltage within $\pm 12.5\%$ of the rated voltage of the particular tap.

Transformers shall be designed for 50Hz +2 % & -5%, unless specified otherwise in design criteria.

Transformers for two or more limits of voltage or frequency or both shall operate satisfactorily at its rated kVA without injurious heating under all the rated conditions of voltage or frequency or both: provided increase in voltage is not accompanied by decrease in frequency.

Transformers shall be suitable for over loading as per IS 6600, unless specified otherwise. Off circuit tap switch, terminal bushings, other auxiliary components/ equipment shall be designed for maximum permissible over loading. Short time over loading to the

extent of 50% shall be considered for this purpose unless specified otherwise.

1.3. Short circuit withstand capability

Transformers shall be capable of withstanding thermal and Mechanical stresses during 3 phase, line to line, double line to earth and line to ground dead short circuits at the transformer terminals, for 2 sec, without any injury. Temperature of the winding prior to the short circuit to be considered for this shall be that corresponding to the maximum permissible value applicable to the overloading cycle specified.

For this purpose, fault and type of system earthing shall be considered as indicated in Design Criteria.

1.4. Vibration and noise level

Design and manufacture of transformer shall be such as to reduce noise and vibration level. The noise level shall be as per NEMA TR-1.

1.5. Harmonics

The transformer shall be designed with particular attention to the suppression of harmonics, especially the third and fifth.

1.6. Flux density

The rated flux density in any part of the core and yoke at rated voltage and frequency shall be such that the flux density shall be 1.7 Tesla.

The maximum flux density in any part of the core and yoke at rated voltage and frequency shall be such that the flux density with + 12.5 percent combined voltage and frequency variation from rated voltage and frequency shall not exceed 1.9 Tesla.

1.7. CONSTRUCTIONAL FEATURES:

Magnetic Circuit

1.7.1. Transformers shall be of core type construction. The cores shall be constructed from high grade, low loss, high permeability cold rolled non-aging grain oriented silicon steel laminations of grade M4 or superior.

Thickness of laminations shall not be more than 0.3 mm. Surface insulation of laminations shall be rust resistant and have high inter laminar resistance. Insulation shall withstand annealing temperature as high as 850 deg.C. The insulation shall be resistant to the action of hot cooling medium.

The insulation structure for the core to bolts and core to clamp plates shall be such as to withstand a voltage of 2000V AC for one minute.

M.S Channel of size indicated in design criteria shall be used for clamping the core and the same shall be painted by Varnish and corrosion oil resistant paint before use. Whenever the CRGO sheets are punched or sheared into laminations, laminations shall be annealed in a non-oxidizing atmosphere to relieve stresses and restore the original magnetic properties of CRGO sheets. The laminations shall be free of all burrs and sharp projections.

The design of magnetic circuit shall be such as to avoid static discharges, development of short circuit paths within itself or to the earthed clamping structure and production of flux components at right angles to the plane of the laminations which may cause local heating.

All steel sections used for supporting the core shall be shot or sand blasted after fabrication.

The finally assembled core and coil assembly shall be rigidly fixed to the tank to avoid shifting during transport, handling and short circuits. Adequate provision shall be made for lifting the complete core and coil assembly.

The supporting frame work of the cores shall be so designed as to avoid the presence of pockets which would prevent complete emptying of the tank through the drain valve, or cause trapping of air during filling.

1.8. Windings

Transformers shall be suitable for earthing system as specified in Design Criteria. The windings shall be fully insulated.

Temperature of winding shall be limited to Maximum 90°C for transformers rated upto 200kVA and shall be 95°C for transformers rated above 200kVA when measured by resistance method.

Hot spot temperature shall be as per IS 2026.

The coil clamping arrangement shall be such as to not impede the free circulation of cooling media.

The windings/ and connection of transformer shall be braced to withstand shocks which may occur during transport or due to short circuits, repeated peak loads and other transient conditions during service.

Windings shall be subjected to a shrinkage treatment before final assembly, so that no further shrinkage occurs during service. Adjustable device shall be provided for taking up any possible shrinkage of coils in service if required.

The conductors shall be transposed at sufficient intervals in order to minimize eddy currents and equalize the distribution of currents and temperature along the windings.

Coil clamping rings shall be of steel or of a suitable insulating material. Axially laminated material other than bakelised paper shall not be used.

Completed core and winding assembly shall be dried in full vacuum to eliminate presence of moisture. After drying process, the full assembly shall be impregnated immediately.

No strip conductors wound on edge shall have a width exceeding six times its thickness.

The winding material shall be aluminium.

All insulating materials used shall be compatible with cooling medium and other materials that come into contact with the insulation system, under all operating conditions.

Windings shall not have sharp bends which might damage insulation and/ or produce high dielectric stresses.

Coils shall be supported using dried and high pressure compressed wedge type insulation spacers at frequent intervals.

All threaded connections shall be locked. Leads from the winding to the terminal board and bushings shall be rigidly supported to prevent injury during short circuits / vibration.

Permanent current carrying joints in the windings and leads shall be welded or brazed.

TENDER NO: GGPL/KKD/C&P/CW/2523/VS

Clamping bolts for current carrying parts inside the transformer shall be compatible with liquid under all service conditions.

1.9. Taps

No taps are required for transformers rated up to 100kVA .

Taps shall be provided on the higher voltage winding of the transformer and shall be arranged so as to maintain as far as possible the electromagnetic balance of the windings.

It shall be possible to vary the voltage in 4 positions by 3 equal steps of 2.5% each for a variation of +2.5% to -5 % for transformers rated above 100kVA upto 200kVA.

It shall be possible to vary the voltage in 6 positions by 5 equal steps of 2.5% each for a variation of +5% to -10 % for transformers rated above 200kVA upto 500kVA.

1.10. Off-circuit tap switch

Tap-changing shall be carried out with the transformer off-circuit by means of links or by means of an externally-operated switch with Mechanical locking device and a position indicator. Arrangement for pad-locking shall be provided.

1.11. Transformer Liquid

Naptha based mineral oil shall be used as transformer liquid and shall conform to IS – 335. All transformers shall be supplied along with first filling of liquid with top up oil being supplied loose in drums. **When the oil is topped up, the oil level as seen at the conservator shall be at “Maximum” level.** All components, insulating materials used in the transformer construction shall be compatible with the liquid under all operating conditions.

Temperature rise of top oil shall be limited to 35°C for transformers rated upto 100kVA and 40 °C for transformers rated above 100kVA up to 500kVA when measured by thermometer method.

1.12. Transformer Cooling

The transformer shall be Oil Natural Air Natural (ONAN) cooled type.

1.13. Radiators

Radiators shall have fixed connection to tank.

1.14. Tank

Tank shall be made from high quality low carbon steel and shall have oil tight welded construction. The transformer tank covers shall be bolted/clamped alternatively welded with tank rim so as to make a leak proof joint. The curb design in case of welded construction shall be such that it is possible to remove the weld and reweld the tank at least two times.

The tanks of all transformers shall be complete with all accessories and shall be designed so as to allow the complete transformer filled with liquid to be lifted by cranes or jacks, transported by road, rail or water without over straining any joints and without causing subsequent leakage of liquid.

In case of transformers up to 200 kVA, plain tank shall be capable of withstanding a pressure of 80 kPa and a vacuum of 250 mm of mercury. Limiting values of the deflections are specified in Cl. 21.7.1 of IS 1180.

For transformers above 200 kVA and up to 2500 kVA, plain tank shall be capable of withstanding a pressure of 80 kPa and a vacuum of 500 mm of mercury. Limiting values

of the deflections are specified in Cl. 21.7.2 of IS 1180.

For three phase transformers up to 2500 kVA, transformer tanks with corrugations shall be designed for a pressure of 15 kPa measured at the top of the tank with no leakage. The base of each tank shall be so designed that it shall be possible to move the complete transformer unit by skidding in any direction without injury when using plates or rails.

Tank cover shall be of adequate strength and shall not distort when lifted.

Tank covers shall have pockets for bulbs of liquid temperature indicators. Thermometer pockets shall have captive screwed top to prevent ingress of water. The pockets shall be located in the position of maximum liquid temperature and it shall be possible to remove the instrument bulbs without lowering the liquid in the tank.

1.15. Lifting and Pulling Lugs

Lifting Lug -Minimum 4 nos. of welded heavy duty lifting lugs of M/S Plate 8mm thick suitable reinforced by vertical supporting flat welded edgewise below the lug on the side wall shall be provided. Lifting lugs shall be suitable for lifting the transformer with liquid.

Pulling Lug – 4 Nos. of welded heavy duty pulling lugs of M/S plate 8 mm thick shall be provided to pull the transformer horizontally.

1.16. Top Cover Fixing Bolts

GI bolts and nuts of size 12mm x 40mm with one plan and one spring washer suitably apart (100mm) shall be used to press the cover.

1.17. HV/LV Terminations

Bare Bushing shall be considered for terminations on both HV and LV side. Further, the HV and LV terminations shall be oriented at 180°.

1.18. Bushings

The transformers shall be fitted on high voltage and low voltage sides with outdoor type-bushings of appropriate voltage and current ratings. The high voltage bushings (3 Nos.) shall conform to IS 2099. The low voltage bushings (4 Nos.) shall conform to IS 7421. Alternatively, the low voltage side may be made suitable for adoption of PVC / XLPE cables of suitable size.

Minimum rated current of the line end bushing shall be 1.5 times the rated current of the corresponding winding ; where repeated peak loads are specified, bushing rating shall be selected accordingly. Rating of LV Neutral bushing shall be same as that of LV line side bushing. Porcelain bushings shall be provided for HV and LV terminations; however for LV terminations epoxy bushings are also acceptable.

Bushings shall be suitable for atmosphere present in the place of installation. Total creepage distance shall not be less than 25 mm/kV of highest system voltage.

The bushing shall be made in two parts. The outer bushing shall be of porcelain. The dimensions of the outer bushing shall conform to relevant part /Section No. of IS 3347 depending on the Voltage Class. The internal bushing shall be of either porcelain or tough insulating material, like epoxy and shall have embedded stem. Metal portion of the internal HV and LV bushing inside the tank shall remain dipped in oil in all operating condi-

tions.

Short time rating and insulation level of bushing shall be same as that for transformer.

The minimum phase to phase and phase to earth external clearances for HV & LV bushings shall be as follows:-

	Minimum Clearances	
	Phase to Phase (in mm)	Phase to Earth (in mm)
HV Bushing	255	140
LV Bushing	75	40

1.19. Conservator

Conservator shall be located in such a position as not to obstruct the electrical connections to the transformer. The conservator volume shall be sufficient to maintain the oil seal from ambient temperature to maximum oil temperature allowed specified elsewhere in the specification, with oil level varying within minimum and maximum levels.

The conservator shall be provided with dial type magnetic oil level gauge with pointer and potential free contacts for alarm/trip. In addition , prismatic type oil level gauge with minimum and maximum levels marked shall also be provided. Taps or valves shall not be fitted to the oil gauge.

Drain plug shall drain the conservator oil completely. One end of conservator shall be bolted into position so that it can be removed for cleaning purposes. If the sump is formed by extending the feed pipe into the conservator vessel, the extension shall be for at least 20 mm. The minimum oil level (corresponding to - 5°C) should be above sump level. Oil filling hole(1 ¼ nominal size thread) with cap shall be provided.

A silica gel breather with inspection window and oil seal shall be mounted at 1.4m above transformer base and connected to the conservator.

1.20. Breathers

Breather joints shall be of bolted type. It shall have die cast Aluminium body and inside container for Silica gel shall be of tin.

1.21. Losses and Impedance

The losses and impedance for various ratings of transformers of 11kV class shall be within the permissible limits. These losses are the maximum permissible.

Rating (kVA)	Max. Losses at 50 % loading (Watts)	Max. Losses at 100 % loading (Watts)	Impedance % (subject to tolerance as per IS : 2026)

63	380	1250	4.5
100	520	1800	4.5
160	770	2200	4.5
200	890	2700	4.5
250	1050	3150	4.5

No positive tolerance shall be allowed on the maximum losses displayed on the label for both 50 % and 100 % loading values.

1.22. Valves and connections

All valves shall be of gun metal/ cast steel, full way type with internal screwed ends and will be opened by turning counter clockwise when facing the hand wheel. There will be no oil leakage when the valves are in closed position. All valves opening to atmosphere shall be fitted with blank flanges. Means shall be provided for padlocking the bottom valves in open and closed position. All valves shall be provided with an indicator to show clearly the position of the valve. Means shall be provided for top and bottom oil sampling. All transformers shall have residual drain plug, bottom drain valve, top and bottom filter valves suitable for connecting to oil filtration unit. The filter valves shall be arranged on opposite sides of the transformer.

1.23. Joints and gaskets

All gaskets used for making oil tight joints shall be of proven material such as granulated cork-bonded with synthetic rubber (SRBC) or synthetic rubber (nitrile) gaskets for oil filled transformers confirming to IS 11149/Type C as per IS – 4253 Part- II .

1.24. Explosion vent/ pressure relief device

Means provided for release of excess pressure generated inside the tank shall be either double diaphragm type explosion vent or pressure relief device. In case pressure relief device is provided, same shall be of sufficient size for rapid release of any pressure that may be generated within the tank and which might result in damage to the equipment. The device shall operate at static pressure of less than the hydraulic test pressure for transformer tank. Means shall be provided to prevent the ingress of rain water. The device shall be provided with potential free contact wired up to Marshalling Box.

The PRD shall be mounted on the main tank and if on the cover, shall be fitted with skirt projecting 25 mm inside the tank and of such a design to prevent gas accumulation.

If diaphragm type explosion vent is used, the diaphragm shall be of suitable design and material and situated above maximum oil level. An equalizer pipe connecting the explosion vent and conservator shall be provided for relieving or equalizing the pressure in the device depending upon design consideration.

1.25. Internal earthing arrangements

All metal parts of the transformer with the exception of individual core laminations, core bolts and associated individual clamping plates shall be maintained at fixed potential by earthing.

1.26. Core clamping structure earthing

The top main core clamping structure shall be connected to the tank body by a copper strip of adequate cross section. The bottom clamp structure shall also be connected to the tank by one or more of the following methods.
By connection through vertical tie rods of the top structure.

TENDER NO: GGPL/KKD/C&P/CW/2523/VS

- a By direct metal to metal contact with tank base maintained by the weight of the core and winding.
 - b By connection to the top structure on the same side of the core as the main earth connection to the tank.
- 1.27. Earthing of coil clamping rings**

Where coil clamping rings are metal, at earth potential, each ring shall be connected to the adjacent core clamping structure on the same side of the transformer as main earth connections.
- 1.28. Earthing of magnetic circuit**

Magnetic circuit shall be earthed to the clamping structure at one point only.
- 1.29. Size of earth connection**

All earth connections, except those from the individual coil clamping rings shall be done by copper conductor with min. cross section of 80 mm^2 . Copper connections inserted between laminations of different sections of core shall not be less than 20 mm^2 .
- 1.30. Fitting and accessories**

Transformer shall be provided with fittings and accessories as specified in Annexure-II

ANNEXURE- I
DESIGN CRITERIA

1	Rating of transformer	63 kVA	
2	Percentage impedance of transformer	4.5% upto 250kVA	
3	3 Phase power supply system in which transformer is to be used		
a)	Primary side (HV) max. voltage	┘ 7.2 kV	┘ 12 kV
b)	System earthing Primary side (HV)	Effectively grounded	
	Secondary side (LV)	Effectively grounded	
4	Max. 3 phase fault levels Primary side (HV)	40 kA	
	Secondary side (LV)	10 kA	
5	Insulation level		
a)	PF withstand in kV (RMS)		
	HV winding	20 kV	28 kV
	LV winding	3 kV	
b)	Impulse withstand KVP		
	HV winding	60 kV	75 kV
	LV winding	NA	
6	Core		

TENDER NO: GGPL/KKD/C&P/CW/2523/VS

	i) Core Clamping	a) ISMC 125 X 65 mm for 500kVA b) ISMC 100 X 50 mm for 250kVA c) ISMC 75 X 40 mm for <= 100kVA
	ii) Core fixing bolt – 2Nos.	a) 20 mm High Tensile bolt for 500kVA b) 16 mm High Tensile bolt for 250kVA c) 12 mm High Tensile bolt for <= 100kVA
	iii) Tie rod insulating medium	Kraft paper tube of thickness 1.5 mm
	iv)	

Annexure-II

Fitting and accessories

1. 1 No. of Rating and Terminal marking Plate.
2. 2 Nos. of Earthing terminals minimum M12 with nuts should be provided on the tank.
3. 4 Nos. of Lifting lugs for the complete transformer as well as for core & winding assembly.
4. 1 no. of Cap for oil filling (on conservator).
5. Drain cum Sampling valve (3/4" normal thread size) with cover preferably steel with plug.
6. 1 No. of Conservator with drain plug .
7. 1 No. Thermometer pocket.
8. Air Release plug on main tank.
9. Platform mounting channels.
10. Uni directional Flat rollers.
11. Inspection hole.
12. Pressure relief device or Explosion vent.
13. Dehydrating breather : Silicagel breather of 500 gms capacity.
14. Oil Level guage shall be provided indicating 3 position of oil marked as be-
low: Minimum (-) – 5 degree C

TENDER NO: GGPL/KKD/C&P/CW/2523/VS

Maximum (+)- 30 degree C to 90 degree C.

15. Off circuit tap switch handle shall be provided with locking arrangement.
16. HT & LT bushings- 3Nos. of HT bushings and 4 Nos. of LT bushings shall be provided with terminal connectors .Each bushing of HV and LV shall be provided with 3 Nos. of brass nuts and 2 Nos. plain brass washers for connecting terminal.LT terminal connectors for 250kVA transformers shall be supplied in separate packing.
17. Radiators: Elliptical/fin/tubular type radiators shall be provided as per design.
18. Arching horns for HT hushing with adjustable type on the ground side.
19. Filter Valve – 20mm dia. shall be provided on the upper side of the tank.

2. 415V Switchboard

2.1. General

- i) The 415V Switchboard Panel shall be designed to carry continuously without overheating, the rated current specified in the schedule of quantities.
- ii) The busbars shall be rated to limit the temperature rise within 40 deg.c over the specified ambient temperature of 45 deg.c (total temperature: 85 deg.c)
- iii) The 415V Switchboard Panel shall comply with IS 8623 Part I&II,IEC 439 and other relevant Indian/International Standards.
- iv) The ratings of incomer and feeders shall be as indicated in schedule of items/ single line diagrams enclosed.

2.2. Construction

- i) The 415V Switchboard Panel shall have sheet steel enclosure cubicle type and shall be
 - a) Floor mounted, self standing/supporting type
 - b) Totally enclosed, dust, damp and vermin proof
 - c) Single front and preferably without rear access.
 - d) With IP 42 enclosure as per IS 2147
 - e) Fully compartmentalized, fixed type, in tier formation with Alumi-

nium busbars

f) Easily extensible on both sides at site

The 415V Switchboard Panel shall have MCCB acting as incomer while the outgoing feeders shall be with MCCBs as indicated in the enclosed single line diagram.

- ii) The 415V Switchboard Panel shall be of indoor, factory assembled, continuous boards suitable for cable entry from bottom.
- iii) The boards shall be provided with lifting eye bolts for each shipping section.
- iv) The cubicles shall be manufactured using high quality CRCA sheet steel of at least 2 mm thick.
- v) Suitable neoprene gaskets shall be adequately provided on all doors and covers for making the boards dust proof.
- vi) All operating handles shall be accessible from the front side of the cubicle. The operating handles shall be suitably interlocked Mechanically with the door such that the door can be opened or closed only with the switch in OFF position. Provision for defeating the door interlock also shall be provided.
- vii) The number of accepted tier formation shall be subject to the condition that the operating handles shall be above 400 mm from floor level and shall not exceed 1800 mm from floor level for convenience of the operating personnel.
- viii) Each unit compartment shall have full metal barrier on all sides except front, which shall be a hinged door. All hinges shall be concealed.
- ix) Each vertical section shall have a busbar alley on one side for tap off to feeders and cable alley on the other side and shall be provided with door/removable covers at the front.
- x) The clearances required at the back and front side, shall be indicated.
- xi) There shall not be more than 6 compartments in a vertical section.
- xii) A base channel/frame of minimum 50 mm height and 2.5 mm thickness shall be provided.
- xiii) All inscriptions shall be on traffolite/anodised aluminium sheets with white letters on black background.

Feeder details

TENDER NO: GGPL/KKD/C&P/CW/2523/VS

- i) 415V Switchboard Panel shall have MCCBs as incomer and outgoing feeders conforming to the detailed specifications given below :
- ii) All incomer feeders shall have 3 indicating lamps, red ,yellow, blue in colour, to announce power supply 'ON'.
- iii) All incomer feeders shall have voltmeters and ammeters with selector switches with off position. All outgoing feeders shall be provided with ammeters with selector switches.
- iv) Incomers of 415V Switchboard Panel shall have specially designed termination arrangements to accommodate multiple cables (as indicated in schedule of items).
- v) Number and ratings/details of feeders are given in schedule of items/SLD

2.3. Busbars, busbar supports, connections

- i) 415V Switchboard Panel shall have metal enclosed chamber for main busbars at the top running throughout the length of the board. The busbar chamber shall have removable covers for easy maintenance.
- ii) Outgoing feeders shall be connected to the main busbars through vertical busbars provided in the busbar alley. Vertical bus bars shall be easily accessible for maintenance. Vertical bus bars for TP&N shall be arranged to run full height of the vertical section irrespective of whether the bottom most section is used or left as empty feeder.
- iii) Busbars (triple pole and neutral) shall be
 - a) Aluminium conductor
 - b) Uniform in cross section through out the length of the bus and identified by colour code throughout.
 - c) Selected giving due consideration to proximity effect.
- iv) All the busbars shall have dynamic stability for the peak current and thermal stability for the specified symmetrical short circuit current for 1 second without any deformation, deterioration or damage.
- v) Busbars shall be provided with heat shrunk insulation.
- vi) An earth bar of adequate cross section for terminating fourth core of outgoing cable shall be provided running throughout the length of the power distribution board at the bottom with provision to connect to shop earth grid at either end of the board. Size of earth bar shall however be not less than neutral bus size. Removable bus link shall be provided between neutral and earth bus bars.

vii) Bus bar support shall

- a) Have high dielectric strength and high impact strength capable of withstanding dynamic stability currents.
- b) Be of non-hygroscopic type
- c) be with anti-tracking barriers
- d) be self extinguishing and fire retardant insulators with ribbed construction to prevent tracking due to dust accumulation and to have larger creepage distance.

viii) Size of the neutral bus shall not be less than half of the size of main busbar.

ix) The busbars shall be rated to limit the temperature rise within 40 deg. C over the specified ambient temperature as indicated in the design criteria.

x) Allowance shall be made for reduction in section by bolt holes.

xi) Busbar, connecting fishplates, zinc bichromated bolts, nuts and washers shall be provided at each end of a shipping section to facilitate connection at site.

xii) The clearance between bare phase power busbars and between phase and earth in air shall not be less than 25 mm and 19 mm respectively.

xiii) All busbar joints shall be of bolted type. Belleville/ spring washers shall be used for joints to prevent loosening.

xiv) Busbars shall be phase identified by colour code.

2.4. Cable alley

i) Each vertical section shall have a cable alley along side

ii) Cable alley shall have adequate space for terminating copper power cables.

iii) Barriers running complete height of the board shall effectively isolate the cable alley from horizontal and vertical busbars.

iv) Bottom cable chamber shall be left free completely for accommodating power cables and shall be completely isolated from vertical busbars.

v) Removable, undrilled gland plates shall be provided for each cubicle/vertical.

vi) There shall be no horizontal cross bracings within 250 mm of gland plates where the cables enter.

TENDER NO: GGPL/KKD/C&P/CW/2523/VS

- vii) All power outgoing terminals shall be brought out to a separate terminal block/strip through solid links with bellows and located in the cable alley.

2.5. Interchangeability

- i) All identical equipment and corresponding parts, accessories shall be fully interchangeable without any modification.
- ii) Components and equipment that are not fully interchangeable are liable for rejection and the supplier shall replace all such items by fully interchangeable ones free of cost.

2.6. Make up of Modules

i) Incoming feeder:

- Shall be MCCB unit of adequate rating in fixed module. MCCB shall be with microprocessor based direct acting self powered adjustable O/C, E/F, S/C release.
- Provided with voltmeter and ammeter with selector switches. Multifunction meter & energy meter shall be provided at the incomer. Meters to have accuracy class 1.0 and size 144 x 144 sq. mm.
- Provided with microprocessor based metering system, MFM with RS 485 communication port and pulse energy output.
- Provided with R, Y, B phase indication lamps and ON, OFF & TRIP lamps
- MCCB shall have 1 NO + 1 NC contacts rated for 6A, AC 11 duty. ACB shall have minimum 4 NO = 4 NC auxiliary contacts rated for 6A, AC 11 duty.

ii) Outgoing MCCB feeders:

- With microprocessor based adjustable, self powered release for O/C, S/C and E/F. In case, E/F release is not possible then ELR with CBCT shall be provided.
- With 1 NO + 1 NC auxiliary contacts rated for 6A at AC11 duty.
- Provided with ON, OFF and Trip lamps, ammeter for all feeders rated 100 A and above

Moulded Case Circuit Breakers (MCCBs):

MCCBs shall be of triple pole construction suitable for panel mounting, Operating Mechanism shall be trip free, quick make, quick break type.

The MCCBs shall be provided with front operating handles and Mechanical ON/OFF indicators. In case of trip, the handles shall rest in an intermediate position.

MCCBs shall be provided with microprocessor-based release for O/C, S/C, and E/F, which shall be fully adjustable.

Where MCCBs are used in the motor starter modules in conjunction with contactor and thermal overload relay, type 2 coordination shall be provided.

MCCBs shall have following accessories and features:

- a) Shunt trip release
- b) Auxiliary contact set of 1 NO + 1 NC contacts
- c) Fault signaling contact set of 1 NO + 1 NC contacts
- d) Insulation shields to isolate the connections between each pole
- e) Finger protection plate to prevent accidental contact

The compartment door shall be interlocked with the handle of the MCCB

2.7. Indicating instruments and current transformers

- i) All indicating instruments (voltmeters and ammeters) shall conform to IS 1248.
- ii) All indicating instruments shall be of taut band flush mounting type size 96 mm x 96 mm and shall conform to 1.5 accuracy class.
- iii) All instruments shall be provided with zero adjusting device for external operation.
- iv) Ammeters shall be suitable for operation on CT and scaled to read actual currents flowing in the circuits.
- v) All measuring current transformers shall conform to IS 2705. The current transformers shall be of cast resin/bakelite housing type, with bar primary, 5A secondary current and class 1 accuracy. The burden of CTs shall be as required by the associated measuring instruments and connecting leads.

2.8. Indicating lamps

TENDER NO: GGPL/KKD/C&P/CW/2523/VS

All indicating lamps shall be of low wattage cluster LED type. Red, Yellow and Blue colour lenses shall be provided for the lamps of the incomer.

2.9. Wiring and terminations

- i) The Emergency Panel shall be completely factory assembled and wired.
- ii) Power connections shall be done by 1100 V grade single core pvc insulated copper conductor or by aluminium strips of sizes adequate for the respective ratings. Control / Aux. wiring shall be by 650 V/1100V grade PVC single core copper conductor of min. cross-section 2.5sq.mm.
- iii) Each wire shall be identified by ferrules at each end in accordance with schematics.
- iv) Wiring to the door shall be done by flexible cable and the cables shall be bunched, sleeved and cleared so that no Mechanical damage can occur to the cables during door movements. All terminations shall be of adequate current rating and size to suit individual feeder rating.
- v) Outgoing power terminals shall be designed for connecting PVC Aluminium/copper cables of sizes indicated in schedule of items/SLDs.
- vi) Not more than 2 wires shall be connected at one control terminal.
- vii) Required number of heavy duty double compression type brass cable glands suitable for the outgoing cables, projected nipple type complete with two locknuts and earthing washer (provided with earth studs) shall be supplied.
- viii) Edge of cable glands shall have threaded projection to enable the locknut to fit from inside of the equipment.
- ix) Terminals, crimping type cable lugs and glands shall be suitable for the cable sizes to be indicated by the Owner during the execution of order.

3. Lighting distribution board (LDB)

A. General :-		
1.0	Type	- Metal clad - Shall be suitable for 415/240V, 3 phase and neutral.
2.0	Construction	- Totally enclosed. - Dust & vermin proof. - Welded back and sides .

TENDER NO: GGPL/KKD/C&P/CW/2523/VS

3.0	Enclosure class	IP54 . IP 55 (with canopy) for outdoor installation .
4.0	Type of execution	Single front.
5.0	Mounting	Wall mounting .
6.0	Installation	Indoor / Outdoor (with canopy).
B. Constructional Features :-		
1.0	Sheet steel CRCA	
	Thickness	2 mm .
2.0	Cable entry	- Incomer :- Bottom cable entry. - Outgoing :- Top / Bottom cable entry.
3.0	Design	- One Incomer and outgoings . - All the components shall be accessible from front - Access to the operating handle of the incoming isolating switch shall be from the front of the cubicle without opening the front door. - Operating knobs of outgoing MCBs shall be accessible from outside without opening the door. The outgoing MCB shall be provided with a glass door. - Protective insulated cover plate (3 mm thick bakelite sheet) shall be provided inside the cubicle to shroud all the live parts .
4.0	Gland plate	Undrilled detachable gland plates (3 mm thick) shall be provided at the top and bottom with suitable gaskets for cable entry.
5.0	Miscellaneous	- Neoprene rubber gasket shall be provided for all the doors , removable covers & between adjacent covers . - Suitable locking devices. - Doors shall have concealed hinges .

TENDER NO: GGPL/KKD/C&P/CW/2523/VS

6.0	Labelling	Clear legible identification labels (anodized aluminium with white letters engraved on black background) with letter sizes of :- - 5 mm for components and module name plates. - Danger board on front and rear sides in English , Hindi and local language .
7.0	Earthing	Two separate earthing terminals shall be provided.
8.0	Limiting dimensions	- Width of SLDB :- 800 mm - Depth of SLDB :- 300 mm - Height of SLDB :- 400 mm (min)
C. Busbars		
1.0	Arrangement	Three phase & neutral.
2.0	Material	High conductivity electrolytic aluminium alloy confirming to grade E91E as per IS-5082 –1981.
3.0	Phase Busbar Rating	- Shall be able to carry continuously the connected load (considering all derating factors) plus a 25% margin . - Max. current density shall be - 1.0 A/sq.mm for Aluminium - 1.5 A/sq.mm for Copper .
4.0	Neutral Busbar Rating	50 % of phase busbar rating
5.0	Short circuit rating	25 kA for 1 sec (or higher as per system requirement).
6.0	Busbar configuration	Red-yellow-blue , black for neutral .
7.0	Busbar insulation	Heat shrinkable PVC - R,Y,B coloured sleeves for phases - Black for neutral.

TENDER NO: GGPL/KKD/C&P/CW/2523/VS

8.0	Busbar supporting insulators	<ul style="list-style-type: none"> - Non-hygroscopic - Flame retarded - Track resistant - High strength - Sheet moulded compound or equivalent polyster fibre glass moulded type .
9.0	Air clearance for bare busbar	Phase to phase :- 25.4 mm (minimum) Phase to earth :- 19.0 mm (minimum)
D. Feeder arrangement		
Incomers		
1.0	Isolating Equipment	4 pole ELCB/RCCB with MCCB . ELCB/RCCB shall be of AC 23 duty category conforming to IS: 13947-1993 having fully shrouded contacts.
2.0	Quantity	One
3.0	Indication Lamps	LED type indicating lamps for :- <ul style="list-style-type: none"> - Power ON R / Y / B .
Outgoing feeder arrangements		

1.0	Circuit breaker	DP MCB
E. Panel wiring		
1.0	Power / current transformer circuit	1.1Kv grade single core , black colour PVC insulated , stranded copper conductor of minimum size 2.5 sq.mm.
2.0	Ferrules	- Numbered plastic/ceramic ferrules. - Self locking type.
3.0	Marking	- Wiring shall be properly marked as per relevant IS.
4.0	Terminals	- Power & control terminals shall be segregated by insulating material like hylam / bakelite sheet. - Terminals shall be ELMEX type suitable for connecting two cores of 2.5 sq.mm wires. - Minimum 20 % spare terminals shall be provided. - The minimum rating of control terminal shall be 10 Amps.
5.0	Cable glands	Double compression cable glands for receiving cables .

4. SPECIFICATIONS OF MAJOR COMPONENTS

Specification of major components are listed as below and shall be followed unless specified specifically in equipment specification. In case of contradiction between parameter of a specific component in equipment specification and here below then parameters indicated in equipment specification shall prevail.

4.1. MOULDED CASE CIRCUIT BREAKER (MCCB)

1.0	Reference standard	IS : 13947 (Part-2) : 1993
2.0	Rated Current	Minimum 100A (frame rating). I rated shall be as per load current with 150% margin with adjustable setting.
3.0	Type	Complete with continuous electronic / microprocessor based adjustable releases.

TENDER NO: GGPL/KKD/C&P/CW/2523/VS

5.0	Short circuit rating	10 kA (Minimum) ($I_{cs} = I_{cu}$). (I_{cs}) = Service Short circuit breaking capacity (I_{cu}) = Rated ultimate short circuit breaking capacity.
6.0	Operating handle	Yes
7.0	Safety Door interlock	Door interlock, Padlocking in ON/OFF position
8.0	Withstand capability	Rated short time with-stand current (I_{cw}) shall be 12 times maximum rated operational current for 1 sec.
9.0	Utilisation category	AC23B
10.0	Electrical features	- S/C , O/C, E/F protection for power supply feeders MCCB's. - Features to minimise the let-through energy (I^2t) in the event of short circuit on load side.
11.0	Auxiliary contacts	1 NO + 1 NC, Alarm contacts.
12.0	Miscellaneous	Can be used in load side or line side vice versa. Shunt trip coil .

4.2. AC CONTACTORS

1.0	Service	Indoor within steel cubicle for maximum system voltage, starting of motors and miscellaneous loads
2.0	Standard	Shall conform to IS / IPSS
3.0	No. poles	3 pole air break .
4.0	Operating type	Magnetic coil operated at 240 V AC. No economy resistors. Insulation for coils shall be class 'E' or better
5.0	Rating	25A (Minimum) , Rated generally for 150% of full load motor rated current. However, contactor ratings with respect to motor ratings are standardized and shall be followed as per Table-1A.
6.0	Interrupting capacity	Ten times the rated current for rated size upto 100A and eight times the rated current for larger sizes.

TENDER NO: GGPL/KKD/C&P/CW/2523/VS

7.0	Duty	According to IEC 158-1 - AC 1 duty :- Non inductive or slightly inductive loads - AC 3 duty :- Squirrel cage motors : starting , switching off motors during running
8.0	Utilisation category	AC23A for unidirectional motors
9.0	Aux. contact requirement	- Minimum 4 NO +4 NC contacts with minimum rating of - 10A , 415 V for rated duty AC-11. - 2A , 220 V for rated duty DC-11. - Shall have the facility of adding add-on contact blocks.
10.0	Closing (pick-up)	85% to 110%
11.0	Dropout	65% to 45%

4.3. CURRENT TRANSFORMERS:

1.0	Type	Bar type primaries and 5A (max) secondary with thermal and dynamic ratings corresponding to the units with which they are used.
2.0	Accuracy class	- Measuring CT accuracy class 1.0. - Protective CT accuracy class 5 P 10.

4.4. CONTROL TRANSFORMERS

1.0	Type	Dry type , cast resin
2.0	Voltage	415V/240V
3.0	Primary taps	+2.5 % , +5 %

4.5. INDICATING INSTRUMENTS

1.0	Basic details	<ul style="list-style-type: none"> - Shall not damage by passage of fault current or existence of over voltage for the maximum permitted duration of fault conditions. - Voltmeters protected by fuses placed as close to the bus-bar as possible.
2.0	Mounting	Flush mounting, square dial with zero adjusting device for external operation .
3.0	Accuracy class	1.5
4.0	Size	<ul style="list-style-type: none"> - Size of voltmeter and ammeter for incomer 144 x 144 mm for incoming feeders. - Size of ammeter for motor feeders 96 x 96 mm.

4.6. THERMAL OVERLOAD RELAYS

1.0	Standard	IEC:292-1
2.0	Basic details	<ul style="list-style-type: none"> - Triple pole - Ambient temperature compensated . - Inverse time lag. - Hand reset type. - Bimetallic with adjustable setting and builtin single phase protection . - Reset PB shall be operable from outside . - Shall be able to withstand prospective short circuit current without damage or injurious heating till the motor protection MCCB clears the fault . - Auto tripping shall be indicated on MCC .
3.0	Contacts	1 NO + 1 NC contacts with minimum rating of <ul style="list-style-type: none"> - 10A , 415 V for rated duty AC-11. - 2A , 220 V for rated duty DC-11.

4.7. PUSH BUTTONS

TENDER NO: GGPL/KKD/C&P/CW/2523/VS

1.0	Basic details	<ul style="list-style-type: none"> - All push button switches including illuminated push buttons shall be of sturdy design - Shrouded actuator for "START" application, and "STOP" application shall be provided. - Mushroom Head actuator for "EMERGENCY STOP" shall be latched type with turn to release. - Press to latch in operated position and turn-to- release in unactuated position. - Double break parallel contact design or other suitable design feature enhancing contact reliability required in circuits with electronic interfaces involving low voltages and small currents shall be adopted.
2.0	Size	- 22.4 mm diameter
3.0	Contact rating	<ul style="list-style-type: none"> - Minimum 2 NO + 2NC contacts (or 4 NC for Em Stop PB) with following current ratings . <ul style="list-style-type: none"> • Continuous - 10 A • AC 11 - 1.5 amps at 240V • DC 11 - 0.5 amps at 110 V DC, L / R - 40 ms - All contact faces of contacts shall be of silver or silver alloy. - Facility of adding addon contact blocks to be provided
4.0	Colour	<ul style="list-style-type: none"> • Accept - Blue • Test - Yellow • Reset - Black

4.8. INDICATING LAMPS

1.0	Type	- LED Cluster type
2.0	Basic details	- Sufficient number of lamp grips shall be provided for easy replacement of lamps.
2.0	Size	- 22.4 mm diameter

3.0	Colour	<ul style="list-style-type: none"> - For motor `ON`, valve/damper/gate `OPEN`, supply `ON`, breaker `CLOSE` : Red - For motor `OFF`, valve/damper/gate `CLOSE`, supply `OFF`, breaker `OPEN` : Green - Fault indication, over load, alarm : Amber condition, `SERVICE & TEST POSITION` indication. - General purpose indication, : White mo- tor `AUTO TRIP`. <p>Other colours may be adopted depending upon particular application as approved by the Owner.</p>
4.0	Layout of indication lamps on boards / panels	<p>Indicating lamps shall be located just above the associated push-button / control switches.</p> <p>Red lamps shall invariably be located to the right of green lamps.</p> <p>In case a white lamp is also provided, it shall be placed between red and green lamps along the centre line of control switch/ push button pair.</p> <p>Blue and Amber should normally be located above the Red and Green lamps.</p> <p>When associated with push buttons, red lamps shall be directly above the green push button and green lamp shall be directly above the red push button.</p>

4.9. MINIATURE CIRCUIT BREAKERS (MCB)

1.0	Type	Heat resistant plastic moulded type,
2.0	Number of Poles	Double Pole (DP)
3.0	Ref . Standard	IS: 8828 –1978
4.0	Protections	MCBs shall be provided with quick break trip-free PM-Chanism and direct acting thermal overload and short circuit trip elements.
5.0	Short circuit capacity	Not less than 9kA at 0.8pf

6.0	Mounting	DIN Channel mounting . Single phase MCBs mounted adjacent to each other and connected to different phases shall be provided with adequate insulated phase barriers.
7	Current Rating	The MCBs shall be selected from standard current ratings.(As per SLD) MCB characteristics curve shall be as per application .

4.10. SELECTOR SWITCHES

1.0	Basic details	<ul style="list-style-type: none"> - Shall have modular construction with number of switching contacts for each position operated by a single shaft. - Inscription for each position shall be provided. - Stay-put or spring return arrangement shall be provided as per the circuit and control/operational requirement. - The contacts shall be designed for higher contact reliability and electronics compatibility involving low voltage and small value of currents. - The operating handle shall be robust and strong. - One number of potential free switching contact for each position shall be provided as spare. - Control switches for circuit breaker ON/OFF control 3 position spring return to neutral with lost motion device and pistol grip handle. - Other control and selector switches - stay put type with wing type knobs.
2.0	Contacts	<p>2 NO + 2 NC contacts with minimum rating of</p> <ul style="list-style-type: none"> - All the selector switches shall be of 10 A rating - 25A for sturdy applications . - 1 NO & 1 NC contact / poles shall be potential free for PLC inputs .

5. CABLES

5.1. HT XLPE CABLES 11 kV / 6.6 kV (E) ,

Sl.No.	Parameter	Description
1.0	Voltage Grade	11 kV (E)/ 6.6 kV (E) as applicable
2.0	Duty type	Heavy duty
3.0	No. of cores	3 cores
4.0	Reference standard	IS:8130 – 1984 IS:5831 – 1984 IS:3975 -1988 IS:1554, part - 1, 1988 IS:3961 (Part-II) - 1967. IS:7098 Part-I & II IEC-60502
5.0	Conductor type	Compact circular stranded (rm/V) aluminum conductor, with extruded conductor shielding of semi conducting material . Conductor construction as per IS 8130-1984.
6.0	Insulation type	XLPE insulated, with insulation shielding over individual cores, consisting of extruded semi conducting compound, followed by lapped semi conducting material and copper tape (non magnetic) metallic screen, cores stranded together with a holding tape provided with a common covering of extruded inner sheath of type ST2 compound . The cable shall conform to IS:7098(Part-2)-1985.
7.0	Armour	Galvanized steel wire armoured . For multi core cables , armouring shall be applied over the inner sheath of flat steel wires (strips) . Round steel wire armouring can also be offered. For single core armoured cables non-magnetic armour consisting of hard drawn flat or round aluminium wires shall be provided.

TENDER NO: GGPL/KKD/C&P/CW/2523/VS

8.0	Outer sheath	PVC outer sheathed of type ST2 compound . Black in colour . Suitable chemicals shall be added into the PVC compound of the outer sheath to protect the cable against rodent and termite attack.
9.0	Miscellaneous	Copper screen shall be suitable to carry 1 KA E/F current for one second.
10.0	Temp. rise on continuous load	90 deg.C
11.0	Oxygen index of outer sheath material for XLPE Cable	Shall not be less than 29 at 27. 2 deg. C.
12.0	Temperature index	Not below 250degC.
13.0	Max. conductor withstand temperature during short circuit.	250degC

5.2. FLAME RETARDANT LOW SMOKE (FRLS) CABLES

Sl.No.	Parameter	Description
1.0	Voltage Grade	1.1 kV grade
2.0	Reference standard	Category AF as per IS : 10810 ASTM-D 2863 (Critical Oxygen Index) ASTM-D 2863 (Temperature Index) ASTM-D 2843 (Smoke density) IEC 754-1 (Acid gas generation)
		IEEE-383 (Flammability test on group of cables) Swedish chimney test SS 424175, class F3. (Flammability test) IEC 332-1 (Flammability test) IEC 332-3 (Flammability test) IS 5831 (Fire resistant test)
3.0	Duty type	Heavy duty
4.0	No. of cores	Single or multicore as per requirement
5.0	Cross sectional area	As per requirement .
6.0	Conductor type	Annealed tinned copper conductor
8.0	Insulation type	XLPE insulation
11.0	Sheath	Specially designed with thermoplastic or thermosetting materials , superior resistance to ignition and flame propagation with smoke emission and toxicity or corrosive characteristics Flame retarded Oil resistant
12.0	Armouring	GI wire / strip armoured as per requirement and size (as specified in respective TS)

TENDER NO: GGPL/KKD/C&P/CW/2523/VS

13.0	Test values	Critical Oxygen Index : Minimum 29 Temperature Index : Minimum 250 deg. C Smoke density : Minimum average light transmission of 40% Acid gas generation : HCl gas released 20% maximum Flammability test on group of cables: As per standards mentioned Flammability test : As per standards mentioned Fire resistant test : As per standards mentioned
------	-------------	--

6. ILLUMINATION
6.1. GENERAL

The lighting system inside and outside the station are designed based on the desired minimum illumination levels recommended by IS.

The illumination system shall be designed as per IS:3646-1992. The minimum level of illumination, type of fittings, maintenance factor to be considered is as given below:

Area	Type of Light Fittings& Lamps	Lux level (min)	MF
Control rooms	Surface mounted / Suspended luminaires with energy efficient LED tube. (CGL type LCTLR-36-CDL).	300	0.75
Electrical rooms having PCC, PDB	Surface mounted / Suspended luminaries with energy efficient LED tube. (CGL type LCTLR-36-CDL).	200	0.7
Offices without false ceiling	Surface mounted / Suspended luminaires with energy efficient LED tube. (CGL type LCTLR-36-CDL).	300	0.75
Battery Room	Industrial vapour proof IP55 luminaire with 2 x 36 W TFL diecase aluminium control gear boxes at the ends with synthetic rubber gasket	100	0.6
Compressor room	Surface mounted / Suspended luminaries with energy efficient LED tube. (CGL type LCTLR-36-CDL).	200	0.6
Flood lighting	Weather proof Flood light luminaire with 120W	70	0.5

TENDER NO: GGPL/KKD/C&P/CW/2523/VS

	LED lamp, IP 65 or better, integral type with aluminium die cast housing. The luminaire shall be complete with control gear, driver & surge protector, heat resistant cover, pre-wired up to terminal block.		
Toilets	Bulk head luminaire (led) similar to CGL CAT.NO. LBH-10-CDL.	100	0.6
Street light Fittings	4 x 24 W Flame proof street light Ex-d type fixture with T5 lamp, control gear in cast aluminium alloy LM6 enclosure and toughened glass cover. The enclosure shall be of IP: 65 suitable for Zone 1 & 2 gas group IIA & IIB with all accessories.	As per IS	0.6
Canopy Light Fittings	Explosion cum weather proof 72 W LED light fitting similar to Baliga Catalogue no. ECRF-236	As per IS	0.6

MF : Maintenance factor

The light fittings shall be complete with all accessories like electronic ballast, reflector etc.

6.2. HIGH MAST SPECIFICATIONS

6.2.1. DESIGN CRITERIA :

The equipment shall be suitable for operation at Hazardous area. The ambient conditions for design of equipments shall be taken as below:-

- | | | |
|-------------------------------|---|---------------------------------|
| a) Design Ambient temperature | : | 50°C |
| b) Maximum humidity | : | 100% |
| c) Altitude | : | Less than 500 mtr. at sea level |
| d) Site condition | : | ---- |
| e) Wind speed | : | 180 km/hr |

6.2.2. STRUCTURE :

The High mast shall be of continuously tapered, polygonal cross section, at least 20 sided, presenting a good and pleasing appearance and shall be based on proven In-Tension design conforming to the standards referred to above, to give an assured performance, and reliable service. The structure shall be suitable for wind loadings as per IS 875 Part 3 1987.

6.2.3. CONSTRUCTION :

The mast shall be fabricated from special steel plates, cut and folded to form a polygonal section and shall be telescopically jointed and welded. The procedural weld geometry and

the workmanship shall be exhaustively tested on the completed welds. Mast can be fabricated in multiple sections of length approximately 10 metres. Thus a 30 M can be delivered in three sections. No site welding or bolted joint shall be done on the mast. The minimum over lap distance shall be 1.5 times the diameter at penetration. The dimensions of the mast shall be decided based on proper design and design calculations shall be submitted for verification.

The mast shall be provided with fully penetrated flange, which shall be free from any lamination or incursion. The welded connection of the base flange shall be fully developed to the strength of the entire section. The base flange shall be provided with supplementary gussets between the bolt-holes to ensure elimination of helical stress concentration. For the environmental protection of the mast, the entire fabricated mast shall be hot dip galvanized, internally and externally, having a uniform thickness of 85 microns for the bottom section and 65 micron for the middle and top sections.

6.2.4. DOOR OPENING:

An adequate door opening shall be provided at the base of the mast and the opening shall be such that it permits clear access to equipment like winches, cables, plug and socket, etc. and also facilitate easy removal of the winch. The door opening shall be complete with a close fitting, vandal resistant, weatherproof door, provided with a heavy-duty double internal lock with special paddle key.

The door opening shall be carefully designed and reinforced with welded steel section, so that the mast section at the base shall be unaffected and undue buckling of the cut portion is prevented. Size of door opening shall be around 1100 x 280 mm and shall be strengthened if required to avoid buckling of the mast section under heavy wind conditions.

6.2.5. DYNAMIC LOADING FOR THE MAST:

The mast structure shall be suitable to sustain an assumed maximum reaction arising from a wind speed as per IS 875 (three second gust), and shall be measured at a height of 10 meters above ground level. The design life of the mast shall be a minimum of 25 years.

6.2.6. LANTERN CARRIAGE:

Fabrication:

A fabricated Lantern Carriage shall be provided for fixing and holding the flood light fittings and control gear boxes. The Lantern Carriage shall be of special design and shall be of steel tube construction, the tubes acting as conduits for wires, with holes fully protected by grommets. The Lantern Carriage shall be so designed and fabricated to hold the required number of flood light fittings and the control gear boxes, and also have a perfect self balance.

TENDER NO: GGPL/KKD/C&P/CW/2523/VS

The Lantern Carriage can be fabricated in two halves and joined by bolted flanges with stainless steel bolts and nylon type stainless steel nuts to enable easy installation or removal from the erected mast. The inner lining of the carriage shall be provided with suitable protective arrangement, so that no damage is caused to the surface of the mast during the raising and lowering operation of the carriage. The entire Lantern Carriage shall be hot dip galvanized after fabrication. The design shall provide a perfect balance for the lantern carriage during raising and to lowering also.

Junction Box:

Weather proof junction box, made of Cast Aluminium shall be provided on the Carriage Assembly as required, from which the inter-connections to the designed number of the flood light luminaries and associated control gears fixed on the carriage shall be made.

Raising and lowering Mechanism:

For installation and maintenance of the luminaries and lamps, it will be necessary to lower and raise the Lantern Carriage Assembly. To enable this, a suitable Winch Arrangement shall be provided, with the winch fixed at the base of the mast and the specially designed head frame assembly at the top. Suitable limit switches shall be provided to trip the winch motor at both top & bottom ends of the designed travel.

Winch:

The winch shall be of completely self sustaining type, without the need for brake shoe, springs or clutches. Each driving spindle of the winch shall be positively locked when not in use, gravity activated PAWLS. Individual drum also should be operated for fine adjustment of lantern carriage. The capacity, operating speed, safe working load, recommended lubrication and serial number of the winch shall be clearly marked on each winch.

The winch shall be self-lubricating type by means of an oil bath and the oil shall be readily available grades of reputed producers.

The winch drums shall be grooved to ensure perfect seat for stable and tidy rope lay, with no chances of rope slippage. The rope termination in the winch shall be such that distortion or twisting is eliminated and at least 5 to 6 turns of rope remains on the drum even when the lantern carriage is fully lowered and rested on the rest pads. It should be possible to operate the winch manually by a suitable handle and by an external power tool. It shall be possible to remove the double drum after dismantling, through the door opening provided at the base of the mast. Also, a winch gear box for simultaneous and reversible operation of the double drum winch shall be provided as part of the contract.

The winch shall be type tested in presence of a reputed Institution and the test certificates

TENDER NO: GGPL/KKD/C&P/CW/2523/VS

shall be furnished before supply of materials. A test certificate shall be furnished by the Contractor from the original equipment manufacturer, for each winch in support of the maximum load operated by the winch.

Head Frame:

The head frame which is to be designed as a capping unit of the mast, shall be of welded steel construction, galvanized both internally and externally. The top pulley shall be of appropriate diameter, large enough to accommodate the stainless steel wire ropes and the multi-core electric cable. The pulley block shall be made of non-corrodible material, like die cast Aluminium Alloy (LM-6). Self-lubricating bearings and stainless steel shaft shall be provided to facilitate smooth and maintenance free operation for a long period. The pulley assembly shall be fully protected by a canopy galvanized internally and externally.

Close fitting guides and sleeves shall be provided to ensure that the ropes and cables do not dislodge from their respective positions in the grooves. The head frame shall be provided with guides and stops with PVC buffer for docking the lantern carriage.

Stainless Steel Wire Ropes:

The suspension system shall essentially be without any intermediate joint and shall consist of only non-corrodible stainless steel of AISI 316 or better grade.

The stainless steel wire ropes shall be of multi strand construction, the central core being of the same material. The overall diameter of the rope shall not be less than 6 mm. The breaking load of each rope shall have factor of safety of over 5 for the system at full load. The end constructions of ropes to the winch drum shall be fitted with talurit.

The thimbles shall be secured on ropes by compression splices. Two continuous lengths of stainless steel wire ropes shall be used in the system and no intermediate joints are acceptable in view of the required safety. **No intermediate joints / terminations, either bolted or else, shall be provided on the wire ropes between winch and lantern carriage.**

6.2.7. ELECTRICAL SYSTEM,CABLE AND CABLE CONNECTION:

A suitable Flame proof terminal box shall be provided as part of the contract at the base compartment of the high mast for terminating the incoming cable. The electrical connections from the bottom to the top shall be made by special trailing cable. The cable shall be EPR insulated and PCP sheathed to get flexibility and endurance, and have copper conductors. The cable shall be of reputed make. At the top there shall be weather proof junction box to terminate the trailing cable. Connections from the top junction box to the individual luminaries shall be made by using 3 core flexible PVC cables of adequate size. **The system shall have in-built facilities for testing the luminaries while in lowered**

position. 2 No's Trailing cable shall be considered for making 2 lighting circuits.

Also, suitable provision shall be made at the base compartment of the mast to facilitate the operation of externally mounted, electrically operated power tool for raising and lowering of the lantern carriage assembly. The trailing cables of the lantern carriage rings shall be terminated by means of specially designed, metal clad, multi-pin plug and socket provided in the base compartment to enable easy disconnection when required.

A **FLAME PROOF TYPE** distribution board with suitably rated 3-phase incomer MCB and separate MCB's controlled feeders for lighting and power tool shall also be supplied. The board shall incorporate timer for control of lighting (**2 circuits**) and control circuit for winch operation with all necessary contactors etc. The board shall have IP 65 protection with rainwater protections canopy and epoxy powder coated suitable for outdoor mounting in coastal area. The work shall also include necessary foundation cable glands etc. complete as required.

6.2.8. POWER TOOL FOR THE WINCH:

A suitable, high-powered, electrically driven, internally mounted power tool, with manual over ride shall be supplied for the raising and lowering of the lantern carriage for maintenance purposes. The speed of the power tool shall be to suit the system. The power tool shall be single speed, provided with a motor of the required rating. The power tool shall be supplied complete with push button type remote control switch, together with 6 (six) meters of power cable, so that the operations can be carried out from a safe distance of 5 (five) meters. The capacity and speed of the electric motor used in the power tool shall be suitable for the lifting of the design load installed on the lantern carriage.

The power tool mounting shall be so designed that it will be not only self supporting but also aligns the power tool perfectly with respect to the winch spindle during the operations. Also, a handle for the manual operation of the winches in case of problems with the electricity operated tool, shall be provided and shall incorporate a torque limiting device.

There shall be a separate torque-limiting device to protect the wire ropes from over stretching. It shall be Mechanical with suitable load adjusting device. The torque limiter shall trip the load when it exceeds the adjusted limits. There shall be suitable provision for warning the operator once the load is tripped off. The torque limiter is a requirement as per the relevant standards in view of the over all safety of the system. Each mast shall have its own power tool motor.

6.2.9. LIGHTNING FINIAL:

One number heavy duty hot dip galvanized lightning finial shall be provided for each mast. The lightning finial shall be minimum 1.2 M in length or as required so that the lantern carriage also comes within the safety zone and shall be provided at the centre of the

head frame. It shall be bolted solidly to the head frame to get a direct conducting path to the earth through the mast. **The lightning finial shall not be provided on the lantern carriage under any circumstances in view of safety of the system. 2 NO'S Copper jumpers shall be provided from lightning final to the mast body.**

6.2.10. AVIATION OBSTRUCTION LIGHTS:

2 No's Neon type Aviation Obstruction Lights of reliable design shall be provided on top of each mast.

6.2.11. EARTHING TERMINALS:

Suitable earth terminal using 12 mm diameter stainless steel bolts shall be provided at a convenient location on the base of the Mast, for lightning and electrical earthing of the mast. The mast shall be provided with duplicate earthing including necessary earth pits as per IS.

6.2.12. FOUNDATION FOR HIGH MAST:

The scope also includes supplying all materials and casting of RCC pedestal foundation along with necessary Anchor bolts etc.,

The detailed drawing considering wind speed for the pedestal foundation shall be submitted and got approved by consultant/Owner before starting of the work.

6.2.13. DATA SHEET:

A technical data sheet covering all the main parts / components shall be SUBMITTED ALONG WITH THE OFFER. (As per standards BSEN-10025, IS-875 & IS-2062).

6.2.14. LUMINAIRES:

Luminaries shall be specially designed with suitable lamp housing and control gears. The luminaries shall be tested as per Indian standards and test reports shall be submitted for approval. The luminaries shall be suitable for installation on high masts. The number and type of light fitting shall be as per SOR. **The Required lux level for each Mast shall be between 20 to 30 lux.**

6.3. LIGHT FIXTURES, LAMPS AND ACCESSORIES:

6.3.1. GENERAL

- i. All the luminaries shall be designed, manufactured and tested in accordance with relevant IS specifications so far as they are applicable.
- ii. All types of light fittings shall be supplied with lamps.
- iii. All the luminaries shall be industrial type with LED with minimum burning time

TENDER NO: GGPL/KKD/C&P/CW/2523/VS

of 50,000 hours with no toxic content with a colour temperature (CCT) \geq 4000K&CRI above 80 . Power factor shall be more than 0.9 and driver efficiency more than 86%. Junction Temperature shall be kept as low as possible so as to increase performance and life time of LED and ensure that the luminaries are as heat efficient as possible. LED Light fittings shall be suitable for operation at an ambient temperature of 50Deg.C. Heatsink temperature rise above ambient shall be limited as per relevant available IS/IEC . For all outdoor fittings , surge arrestors shall be provided.

- iv. All the light fixtures shall be complete with all parts along with LED lamps/tubes, drivers and accessories for installation and efficient performance whether specifically mentioned in the specification or not. LED fittings shall be selected so as to provide correct colour appearance and rendering to enable workers to see & judge quickly and accurately, details of their work such as colour, brightness, shape form etc.
- v. Individual light fittings shall be provided with suitable arrangements for GI threaded conduit entry of 19 mm dia unless otherwise specified. Terminals of all fittings shall be suitable for taking 2.5 sq. mm flexible, copper conductor PVC insulated, FRLS-PVC sheathed cable.
- vi. Fittings shall be supplied with all inter – connections made and fully wired up to the terminal block and shall be suitable for mounting on wall / column / ceiling / suspension (from the ceiling including suitable bracket).
- vii. All the luminaries shall be commercial / industrial type as per specific requirement. Specification for the various types of LED mentioned in the schedule of quantities shall be followed. All the lighting fixtures shall be complete with all parts, including Earthing arrangement and accessories for efficient performance whether specifically asked in the specification or in the schedule of items or not.
- viii. All live parts shall be provided with suitable sleeves to prevent accidental contacts. The Earthing terminal in the fitting shall effectively earth the body of the entire luminaries
- ix. The luminaries shall be suitably designed to provide economically the required level of illumination on the working plane when mounted at normal standard height in accordance with the type of fixtures.
- x. The luminaries shall be suitable for operating at normal supply voltage of 240 V, single phase, 50 Hz with voltage variation of +/- 10% or at voltages as specified. Electronic Ballast's/drivers shall be used for all fittings. P.F correction capacitor to improve P.F up to 0.95, electronic igniter, necessary connectors etc., shall also be provided where required.
- xi. The clearance between the live parts and the enclosures earthing and other safety factors shall be governed by the latest revisions of the IS specification and IE rules.
- xii. Mounting accessories like chain, for fittings mounted in false ceilings anchor bolt

and all erection accessories required for complete installation is in the scope of the contractor. The price for same shall be included in the fitting cost.

- xiii.** Down rods / chains for mounting light fittings and fans and GI conduits, brackets, flats, hooks, channels, etc., also to be supplied and installed as required. The price for same shall be included in the fitting cost.
- xiv.** All luminaries are to be supplied with required lamps as indicated in the drawings / specifications.
- xv.** All discharge lamp fittings shall be supplied with suitable ballast, power factor improvement capacitor, igniter, etc. The ballast terminals shall be made for various tapings for use on a wide range of mains voltage making it versatile in application.

6.3.2. NON HAZARDOUS AREA LIGHT FIXTURES

A. DECORATIVE LED LIGHTFITTING SIMILAR TO CGL CAT.NO. LCTLS-36- CDL :

Decorative type light fitting suitable for energy efficient LED lamps with high efficiency diffuser and CRCA powder coated body, IP20 or better for surface / recessed mounting accommodating all electrical accessories pre-wired up to a terminal block. It shall have optimum glare control and shall be aesthetically appealing with distinguished looks. Fitting type shall be similar to the type mentioned in the price schedule.

B. FLOOD LIGHT LUMINAIRE (LED) SIMILAR TO CGL CAT. No. LSFO-120-CDL:

Weather proof Flood light luminaire with 120W LED lamp, IP 65 or better, integral type with aluminium die cast housing. The luminaire shall be complete with control gear, driver & surge protector, heat resistant cover, prewired up to terminal block.

C. AVIATION OBSTRUCTION LUMINAIRE (SUITABLE FOR NEON

LAMP) : Aviation obstruction lights shall consist of yellow painted cast aluminium body housing, with led LAMP and heat resistant, clear, toughened, thick glass dome mounted on hinged die cast aluminium ring secured to the body. The luminaire shall be provided with Neon spiral plugged into spring loaded high tension nylon socket and wired up to the terminal block. The luminaire shall be suitable for mounting on a pipe bracket.

D. BULK HEAD LUMINAIRE (LED) SIMILAR TO CGL CAT.NO. LBH-10-

CDL : The body of the fitting shall be made of epoxy powder coated die cast aluminium fitted with acrylic diffuser and frame. Proper sealing of inside against outside influences like water vapour etc., is to be achieved. The fitting shall be provided with electronic driver. The housing shall have suitable conduit threaded entry and fixing lugs shall be provided for mounting on wall / ceiling. All MS

hardware parts shall be cadmium plated and passivated to withstand corrosion. The fitting shall be weather proof IP:65.

E. STREET LIGHT POLE:

The Octagonal Poles shall be designed to withstand the maximum wind speed as per IS 875. The top loading i.e area and the weight of Fixtures are to be calculate maximum deflection of the poles and the same shall meet the requirement of BS: 5649Part VI 1982. Each pole shall comprise of FLP looping/terminal box (IP:66-polycarbonate type) clamped with top level 1200mm above ground level along with a suitable earth terminal. A base plate 300 x 300 x 10mm welded to the bottom of the pole. The looping box shall be provided with a suitable bus bar arrangement to loop 3 to 4 cables (type and size shall be as per schedule of items/drawings). 2A DP MCB and an earthing terminal shall be provided.

The pole shaft shall have octagonal cross section and shall be continuously tapered with single longitudinal welding. There shall not be any circumferential welding. The welding of pole shaft shall be done by Submerged Arc welding (SAW)process.

The welding shall be carried out conforming to approved procedures and duly qualified by third party inspection agency. The welders shall also be qualified for welding the octagonal shafts.

Octagonal Poles : HT Steel Conforming to grade S355JO Foundation Bolts : EN.8grade.

Base Plate : Fe410 conforming to IS226 / IS2062

The octagonal poles shall be in single section (upto 11mtr). There shall not be any circumferential weld joint.

The pole shall be provided with a cap having 3 nos. fixing bolts at 120 degrees apart, pipe arm with suitable stiffeners shall be provided to mount the street light fitting. The dia of the pipe shall be suitable to carry the weight of fitting etc and suitable for mounting the fitting.

The pole shall be provided with necessary cross arms as per schedule of items for mounting one or more numbers of street light fittings where required. Both underground cable and earth cable shall be terminated at the terminal/looping box. Further wiring to the light fixture shall be done by three core flexible copper wire (2 core for power supply and third core for earthing). The earth terminal at the terminal box shall be further connected to the earth terminal on the pole by aluminium cable.

Steel octagonal pole cap and all other MS material shall be epoxy painted hot dip galvanized to 80 micron thickness. All hardwares like nuts, bolts, etc shall be of stainless steel or zinc passivated.

The octagonal poles shall be bolted on a precast foundation with a set off our foundation bolts for greater rigidity. The civil work for street light pole foundation forms a part of erection.

The poles shall be hot dip galvanized as per IS2629/ IS2633 /IS 4759 standards with average coating thickness of 70 micron. The galvanizing shall be done in single dipping.

The scope also includes supplying all materials and casting of RCC pedestal foundation along with necessary Anchor bolts etc.,

The detailed drawing considering wind speed for the pedestal foundation shall be submitted and got approved by consultant/Owner before starting of the work.

Steel tubular poles shall conform to IS 2713 Part II – 1980 with designation as specified in the BOQ.

F. TIMER

Timer (Time switch) shall be accurate & quartz driven. The timer shall have an built in chargeable Ni-Cd cells for 150 hours continuous operation in the event of power failure. The timer shall be suitable for switching ON / OFF street lights, open area lights, boundary wall lights etc., at predetermined time.

6.3.3. SOCKETS, SWITCHES, FANS AND OTHER INSTALLTION ACCESSORIES:

A. SOCKET OUTLETS:

i. FLUSH/SURFACE MOUNTING SOCKET OUTLETS (DECORATIVE TYPE)

6A / 16A, 6A, 240V, single phase, 3 pin (two pole and one earth) socket outlet shall be flush / surface mounting type along with decorative type switch. The socket shall be 6A / 16A combined (universal type) having 6 pin, or 16A, 3 pin with suitable piano type switch.

ii. INDUSTRIAL TYPE PLUG SOCKET OUTLET

10A/20A, 240V, single phase, 3 pin (two pole and one earth) industrial type socket outlet with interlocked switch. The outer casing shall be made of non-corroding die cast aluminium alloy, moulded of superior grade phenolic /polyester compound.

B. JUNCTION AND OUTLET BOXES :

Junction and outlet boxes fabricated with sheet steel shall have a minimum thickness of 1.6 mm / polycarbonate unless otherwise specified in schedule of items. All these items shall be painted whether indicated specifically in the BOQ or not. The JB shall have earthing terminals & terminal block, required no. of knockouts for cable entry etc.,

The exact size and number of knockouts & cable glands shall be decided by the Contractor as per actual requirement.

C. CONTROL SWITCHES :

i. DECORATIVE TYPE

Single pole decorative type, 6A or 16A switches shall be used for light point wiring in control rooms, office premises/non plant buildings.

All branch switches shall be placed in line conductor of the circuit and no single switch or fuse shall be inserted in the neutral conductor of the circuit.

- ii. **SWITCH BOARDS (FOR DECORATIVE SWITCHES AND SOCKETS)**
: The switch board shall be made of 1.6 mm thick sheet steel and painted / polycarbonate including supports for switches, sockets, fan regulator etc., but excluding front cover in case of decorative switches & sockets which will be of FRP sheet of approved quality, design and colour. Clear depth of the box shall not be less than 60 mm, but adequate for easy mounting of fan regulators. All fittings shall be in flush pattern in case of concealed wiring. The FRP cover sheet thickness shall not be less than 4 mm. No separate payment will be made for switch boards as the cost of this has to be included along with the rate quoted for socket, point wiring, switches and fans. In case of more numbers of sockets / switches / regulators are to mounted in one location, these can be mounted in a bigger size switch board with necessary clearance etc., between switches instead of individual switch board for each switch. Sheet steel enclosure shall be painted with two coats of epoxy paint above two coats of epoxy based primer.
- iii. **BOLTS & NUTS / BRACKETS / DOWNRODS / CHAIN:**
All screws, bolts nuts and washers used for Illumination work shall be of brass or cadmium passivated MS to resist corrosions. All brackets, down rods, chains used for suspension of light fittings shall be made of MS Conduits / channels / angles / strips as approved by site engineer. Two coats of epoxy spray painting shall be applied over two coat of epoxy based primer for all accessories.
- iv. **CEILING ROSES / LAMP HOLDERS FOR POINT WIRING :**
a. Ceiling rose may be used in the wiring, as required.
b. Normally only one flexible cord shall be attached to a ceiling rose. Specially designed ceiling roses shall be used for multiple pendants.
c. All ceiling roses shall be of three plate pattern.
d. All lamp holders shall be of brass and batten or angle type as required with shrouding.
- v. **CEILING FAN FANS AND REGULATORS :**
a. All ceiling fans supplied shall be conforming to relevant IS and with capacitor starting, 5 star rated suitable for voltage range of not

less than 220 V to 240 V AC single phase supply.

- b. Fans shall be supplied complete with fan motor, fan blade, insulated hangers canopy and regulator along-with a down rod of suitable length as required. The speed regulators shall be of electronic type for steeples variation from zero to 100%. All ceiling fans supplied shall have double ball bearings.
- c. All ceiling fans shall be wired to a junction box and suspended from a hook in shackle and insulated from the same. All joints in the suspended rod shall be screwed and all joints or bolts in connection there with shall in addition be secured by means of split pin.
- d. The canopy at the top of the suspension rod shall effectively hide the suspension.
- e. The lead-in wires shall not be smaller than 0.75 Sq.mm (24/0.2 mm) PVC insulated flexible copper conductor cable and shall be protected from abrasion.
- f. Unless otherwise stated, all ceiling fans shall be hung at 150mm above the light fitting level or as directed by the Engineer in-charge. The length of the down rod supplied shall be suitable for this purpose.
- g. Generally the ceiling fans shall be mounted 2500/3000, above FFL. The down rod length shall be considered based on roof profile (slope or flat).

vi. EXHAUST FAN :

Exhaust fan shall have totally enclosed with highly efficient heavy duty motor mounted on ball bearing, precisely and dynamically balanced blades/impeller to ensure smooth and trouble free operation, rigid frame with rubber pads for silent operation finished with epoxy based painting for better chemical, Mechanical and corrosion resistant. The exhaust fan shall be supplied with wire guard/bird mesh screen as required.

The exhaust fan shall be provided with earthing terminal. Battery rooms shall be provided with minimum two exhaust fans. All toilet blocks / Pantry shall be provided with Exhaust fans.

6.3.4. CABLES & WIRES:

A. CABLES:

Cables shall be used for power supply to lighting boards and all outdoor installations.

B. WIRES :

TENDER NO: GGPL/KKD/C&P/CW/2523/VS

1100V grade PVC insulated FRLS, PVC sheathed round wire armoured PVC overall sheathed cable with stranded copper conductors (YRY) not less than 2.5 sq mm cross-section shall be used for wiring for connecting from distribution board to outdoor light fittings and not less than 4 sq mm cross-section for power circuits. Where the number of cables is less it is permitted to directly fix the cables on GI saddles and a common clamp for the the cables. Cables shall be cleated at intervals not exceeding 1000mm. Generally, cables shall be laid in such a manner to avoid crossing / jumping of cables over each other and shall provide a neat and tidy appearance. Suitable size compression brass glands shall be provided for cable entry / exit.

C. POINT WIRING:

Supply and wiring of 1100V grade, FRLS, PVC insulated single core Copper conductor wire (without joint) drawn into the 19 mm dia concealed PVC Conduit for Light points and 25mm dia. PVC conduit for power points (including supply of conduit). The scope covers pulling the wire from switch box to lighting / exhaust fan point through the conduit and connecting both the ends with all accessories like bends, junction boxes and couplers, factory made covers for all the pull JB's, including breaking of wall etc.

The wiring for lighting, fans and socket outlets shall be carried out on point wiring basis. Point wiring shall be done in conduits using 3 runs of single core 1100V grade , FRLS,PVC insulated stranded copper wire as per IS:694 as specified in BOM.

The 6A sockets shall be of universal type. The sockets shall be flush mounting type. Every switchbox shall consist of 6A socket outlet controlled by a 6A switch.

The switchbox shall be suitable for concealed flush mounting in walls. Necessary chipping of walls for installing the switchbox and making the wall good after installation of the switch box shall be included in the scope. The switchbox shall be made from galvanized sheet steel and shall have a provision for earthing from inside. The boards shall be covered with poly carbonate front cover having good aesthetic look suitable for mounting modular switches and sockets.

Point wiring shall include supply and installation of 1.5 sq.mm,2.5 sq.mm, 4 sq.mm & 6 sq.mm Cu wires, 19mm rigid PVC conduits and wiring accessories like pull box, ceiling roses, fittings including circular/rectangular sheet steel/thermoplastic bends, tees, sockets, adopters, reducers, saddles, distance pieces etc for concealed wiring as per requirements to complete the lighting/fan/exhaust fan wiring of rooms. PVC insulated multi stranded copper wires of 1.1 KV grade with ISI certification shall be used. The following colour code shall be adopted for wiring:

TENDER NO: GGPL/KKD/C&P/CW/2523/VS

Phase : Red/Yellow/Blue Single phase wiring : Black Neutral : Green

Primary point is the light/fan point wiring from the switch box to one light fitting / fan via the switch. Secondary points are light points looped from the primary light point or from the nearest secondary light point in the same lighting circuit.

All electronic ballasts for light fittings shall be low loss type with total harmonic distortion not more than 30% and power factor greater than 0.9.

D. TESTS :

All tests conducted shall be as per IS amended up to date. Type test certificates shall be submitted at the time of approval of specific makes.

E. CONDUITS :

i. PVC CONDUIT

Rigid heavy duty PVC conduit as per IS : suitable for electrical wiring may also be used wherever indicated in the approved drawings or specifically approved by Engineer. It shall be of approved make.

ii. PVC CASING, CAPPING & ACCESSORIES

PVC casing, capping & accessories like Tees, elbows, JB's shall be of heavy duty fire retardant self extinguishing, Acid & Alkali resistant, PVC toughness that will not dent, snap-fit covering, desired colour.

iii. GI PIPES

All the pipes supplied shall be suitable for cable drawing, without any internal burrs, smooth internal surface and threaded at both ends with coupling at one end

Class 'B' type GI pipes as per IS shall be used for the following cable routes:

- a. Cables running on floor shall be laid in buried pipes.
- b. All cables laid upto a level +200mm from floor level shall be in GI pipes.
- c. Cables crossing road, entering building from outside through wall/foundations etc. shall be laid in GI pipes.
- d. All GI pipes shall have a suitable fish wire for drawing cable.

6.3.5. EARTHING:

Earthing shall confirm to IS 3043 – 1987 and relevant OISD.

A. EARTHING OF LIGHTING DISTRIBUTION BOARDS :

The lighting board shall be provided with two separate earth terminals. An earth bus bar of appropriate cross section shall be provided inside the lighting board and connected to the earth terminals provided on either side of the board.

Adequate number of holes / terminals shall be provided on earth bus with suitable provision for terminating the earth wire.

GI strip / GI wire insulated single core cable of suitable size shall be used for earthing the lighting board, by connecting the two earth terminals separately to the earthing main in the shop / earth pit.

B. EARTHING OF LIGHT FIXTURES AND SOCKET OUTLETS :

The single core PVC insulated / bare copper wire or 14 SWG GI wire and the third core of the flexible wiring cable shall be used for earthing the light fixtures and single phase socket outlets etc.,

C. EARTHING OF METAL BOXES AND BRACKETS :

Not less than 14 SWG GI wire or suitable size PVC insulated copper wire shall be used for earthing all metal boxes and brackets.

**D. EARTHING OF STREET LIGHT POLES/SOLAR LIGHTING POLES/
FLOOD LIGHTING POLES :**

At every 5th pole including end poles a separate earth station shall be provided. The poles will be earthed by connecting its earth terminal to the junction box through 8 SWG GI wire. Apart from the above, continuous earthing connection from pole to pole shall be carried out using single core PVC insulated PVC sheathed armoured cable with aluminium conductor.

The earth terminal at the junction box shall be connected to the main earthing ring through GI 25 x 5 mm flat.

6.4. HAZARDOUS AREA ILLUMINATION:

6.4.1. GENERAL :

All the equipment's installed and accessories used shall conform to the requirements stipulated under relevant OISD / IEC / Indian Standards for the type / category of installation. All the equipments and accessories installed in these areas shall be certified by CMRS, Dhandbad for using in that particular types of hazardous atmosphere like flammable gas / Vapour or hazardous dust. All the equipments installed shall not attain more than the maximum permissible surface temperature specified for that area elsewhere in the specification, if not the maximum permissible temperature may be assumed as 100 degree C. It shall be ensured that overheating / sparking whether in normal use or under fault condition is confined within the approved housing of wiring system and electrical

item concurred. If any equipment is likely to produce more than the prescribed maximum permissible surface temperature due to abnormal conditions of operation or during fault conditions, all such fittings shall be fitted with a thermal device to disconnect the appropriate circuit before the maximum safe temperature is exceeded.

This bimetal thermally operated cutout device shall preferably be included in the enclosure containing choke and other control gears liable to be over heated. THIS THERMAL DEVICE SHALL NOT BE AUTOMATIC SELF-RESETTING TYPE. If control gears are not integral with the fitting the enclosure for the control gears also shall be suitable for use in that particular type of hazardous atmosphere and certified by CMRS, Dhandbad. For all the equipments where cast iron body is specified, cast Aluminium alloy (LM-06) is also acceptable. All the equipments if constructed out of Aluminium alloy, its external surfaces shall be smooth finished to be free from frictional sparking hazard. All the equipments shall have markings, warning inscriptions and interlocks, specified as per relevant I.S, inscribed either by raised lettering or cast integrally with or by a plate permanently attached to the body of the fitting. Copy of CMRS, Dhandbad, and certificate for each type of fitting should be submitted.

6.4.2. LIGHT FITTINGS :

- i. FLAME PROOF STREET LIGHT FITTING SIMILAR TO CGL CAT. NO. FSL 424**
4 x 24 W Flame proof street light Ex-d type fixture with T5 lamp, control gear in cast aluminium alloy LM6 enclosure and toughened glass cover. The enclosure shall be of IP: 65 suitable for Zone 1 & 2 gas group IIA & IIB with all accessories.
- ii. FLAME PROOF SIMILAR TO Baliga CAT. NO. ECRF-236**
The fitting shall have a Aluminium alloy LM 6 enclosure , toughened Glass Window and Surface mounting arrangement with control gear housing the terminal box. The enclosure shall be IP 66 suitable for Zone 1 with all accessories.
- iii. INDUSTRIAL VAPOUR PROOF LIGHT FITTING**
Industrial vapour proof IP55 luminaire with 2 x 36 W TFL diecast aluminium control gear boxes at the ends with synthetic rubber gasket connected by MS pipe finished in hammer tone grey.

6.4.3. SWITCHES, SOCKETS AND OTHER ACCESSORIES :

The enclosures shall be of cast iron construction having an integral terminal chamber. The front cover shall be secured to the body either by a threaded joint or by special type screws. The box shall have minimum two earthing provision outside and preferably one more inside. The switches and sockets shall be supplied with suitable double compression FLP type cable gland and cable entry / exit provisions shall be as per specific requirements. The enclosure shall have suitable provision for mounting on wall / column. The

contact of the switches shall be suitable for heavy duty and shall be able to make and break the specified rated current effectively. The enclosure shall be suitable to contain the spark / arc created during the operation of the switch effectively from the outside atmosphere. The entire equipment shall conform to the relevant standards and certified by the appropriate authorities for use in hazardous areas having flammable gases or Vapour and explosive dust.

All the accessories such as Pull/anchor/ceiling/junction/outlet boxes specified for use in hazardous areas should conform to the relevant standards and certified by CMRS, Dhandbad. The body of all the above boxes shall be made of cast iron or cast Aluminium alloy and shall have a removable cover plate. The cover plate shall have either a threaded joint or a screwed joint with the body. The number of cable entries shall be as per the requirement.

6.4.4. FLAME PROOF EXHAUST FAN :

Exhaust fans shall have flame proof, highly efficient heavy duty motor mounted on ball bearing, precisely dynamically balanced blades / impeller to ensure smooth to trouble free operation, rigid frame with rubber pads for mounting to reduce vibrations for silent operation, finished with stove enameled epoxy powder coated for better chemical, Mechanical and corrosion resistant. The exhaust fan shall be supplied with wire guard / bird mesh screen as required.

6.4.5. FLAME PROOF MCB DISTRIBUTION BOARDS :

All equipments shall be designed suitable for operation in hazardous areas having flammable gases or Vapour and explosive dust. The distribution board shall be wall / floor mounted type made of cast iron / cast Aluminium LM6 with anti corrosive and light grey epoxy coated finish. The incoming cable terminals, outgoing cable terminals and the switch are all housed in separate chambers. The operating handle of the incomer shall be suitably inter locked Mechanically with the door of the incomer. The boards are provided with neoprene gasket. Suitable cable entries shall be provided for incomer and outgoing. The boards are provided with 2 Nos. external and 1 no internal earth terminals. The entire equipment shall conform to the relevant standards and certified by the appropriate authorities for use in hazardous areas.

6.4.6. WIRING :

A. GENNERAL:

For general requirements for wiring refer to the details stipulated under specifications for wiring for Ordinary (non-hazardous) area elsewhere in this specification. Additional requirement for carrying out wiring in the hazardous areas are as specified below.

B. USING ARMOURED CABLES :

- i. 1100V grade XLPE insulated FRLS PVC sheathed round wire armoured PVC overall sheathed cable with copper conductors shall be used for wiring wherever surface laid cables are specified for connecting from distri-

TENDER NO: GGPL/KKD/C&P/CW/2523/VS

- bution board to light fittings and other equipment.
- ii. While carrying out surface wiring using armoured cables, cable shall be supported 500mm apart to avoid sag. The cables shall be neatly clamped and should not create a shoddy appearance.
 - iii. The rate quoted shall include the cost of accessories required like FLP junction boxes, saddles, consumables, etc., for supply and installation of complete wiring system.
 - iv. Cables shall be laid in such a manner to avoid crossing / jumping of cables and shall provide a very neat and tidy appearance.
 - v. Suitable size double compression brass glands (Approved by CMRS as suitable for flameproof area) shall be provided for cable entry / exit to any of the flameproof apparatus.
 - vi. The cables used shall have multi-strand copper conductor.
 - vii. Nylon/rawl plugs shall be used for fixing cables to ordinary wall / ceiling. The plugs shall be fixed using the correct size of drills and screws as specified by the manufacturer. Using of wooden plugs is not permitted.

C. WIRING USING PIPES :

- i. Wiring in the hazardous areas can be carried out using 1100V grade PVC insulated FRLS PVC sheathed cable with copper conductor in surface laid solid drawn or ERW welded pipe, if specified, for connecting from distribution board to other equipments in flame proof areas.
- ii. Conduits shall be supported at a minimum distance of 1000mm horizontally and 500mm vertically, Nylon / rawl plugs shall be used for fixing conduits on wall / ceiling. The plugs shall be fixed using correct size of drills and screws as specified by the suppliers. Using of wooden plugs is not permitted.
- iii. Conduits shall be laid in such a manner to avoid crossing of conduits.
- iv. Metal conduits are to be screwed tight to the apparatus. Conduit unions only are to be used for jointing and couplers are not allowed.
- v. Flexible conduits are NOT allowed for use in hazardous areas.
- vi. Cables with multi-strand conductors only are permitted for use in conduit wiring system for hazardous areas.
- vii. The rates quoted for the conduit system shall include the cost of accessories required for supply and installation of a complete conduit system e.g., saddles, consumables etc.,

D. CONTROL OF ELECTRICAL SUPPLY CIRCUITS :

- i. The supply of electricity to a building or underground site containing explosives is to be controlled by one or more master switches outside the building or underground sites. Master switches should be in close proximity

ty to each other, identified and capable of isolating every conductor entering the building including the neutral of switches, starters, etc., If installed inside the building, these should confirm to the category of installations.

- ii. All circuits are to be provided with protection against over load and earth leakage. Over current protection may be given by automatic circuit breakers complying with IS : 3842 (Part-I) 1967.

6.5. CONTROL ROOM SWITCH BOARD;

1.0	Location	Control room for controlling the lighting fixtures
2.0	Type	Flush mounted type
3.0	Construction	Fabricated from 14 SWG MS sheet with 6mm thick bakelite cover Shall have conduct knockouts on the sides.
4.0	Switch Mechanism	Modular switches shall be provided
5.0	Power source	The switchboards shall be fed from SLDB of respective area.

6.6. 240V SWITCH SOCKET OUTLET;

1.0	Type	1 pole, 3 pin with third pin earthed industrial type receptacles . non-reversible, metal-clad, dust proof, industrial type suitable for horizontal insertion.
2.0	Rating	240 V AC , 15A,
3.0	Construction	Metal clad gasketed construction, weatherproof All socket outlets shall be supplied with heavy- duty type plug and cap with chain.
4.0	Isolation Switch	rotary type switch mounted flush in the socket outlet box. The isolating switches shall be manually operated industrial type of category AC 22.

TENDER NO: GGPL/KKD/C&P/CW/2523/VS

5.0	Protection	Operating handle of the rotary switch shall be fixed in such a manner that it shall not be possible either to insert or withdraw the plug without switching off the supply.
6.0	Cable entry	Suitable for cable entry through 20mm dia. conduit.
7.0	Mounting	Wall / column mounting
8.0	Inscription	Inscription plate shall be provided indicating the voltage and current rating of the switch socket outlet.
9.0	Miscellaneous	In hazardous area, flame proof switch socket outlet shall be provided.

6.7. 240 V SINGLE / DOUBLE POLE SWITCHES:

1.0	Application	The switches are intended for controlling lighting circuits
2.0	Type	Weather and dustproof and industrial type
3.0	Design	The rotary or toGGPL switches provided shall be of sturdy design
4.0	Standard	As per IS : 6875 (Part-3) - 1980
5.0	Housing	The unit shall be housed in cast iron or cast aluminium box having gasketted, screwed front cover plate, fixing lugs and suitable provision for terminating conduit/cable at the top, bottom or sides as specified.
6.0	Mounting	DIN Channel mounting . Single phase MCBs mounted adjacent to each other and connected to different phases shall be provided with adequate insulated phase barriers.
7.0	Terminal suitability	Terminals suitable for aluminium conductor cables.

7. ERECTION SPECIFICATION:

TENDER NO: GGPL/KKD/C&P/CW/2523/VS

7.1. GUIDELINES FOR DESIGN OF SYSTEM AND ENGINEERING THE LAYOUT OF ELECTRICAL EQUIPMENT.

7.1.1. General

The tenderer shall execute the work at site based on layout drawings furnished by consultant/client.

7.1.2. DESIGN REQUIREMENT FOR ELECTRICAL & CONTROL ROOM BUILDINGS

- All electrical room shall have adequate space to accommodate the electrical equipment from the point of view of operation and maintenance, and conform to IE Rules & Regulations.
- All electrical rooms shall be constructed with heatproof material at the roof if it is exposed to sunlight.
- All Electrical buildings/MCC rooms shall be of Civil construction, with suitable drainage for rain water.
- Suitable exhaust ventilation system shall be provided for rooms housing PDBs, Emergency panel, Capacitor bank etc.
- Ceiling fans shall be provided in office rooms.
- Exhaust ventilation system for toilets, store rooms, etc.
- Entry/Exit for the electrical room shall be provide minimum 2500x2000 with MS doors. All doors shall open outside.
- The height of rooms housing LT Panels, PDB, Capacitor bank etc shall be decided considering minimum 5.0mtr clear height shall be provided.
- The wiring of light fittings in the buildings shall be concealed type. Modular switches shall be used in the control rooms, office rooms, etc. (which are not required to glow continuously) for switching ON/OFF the lights/fans.
- Electrical rooms, control rooms shall be considered fire hazardous.
- Roofs of the electrical premises shall be fully watertight and moisture proof.

7.1.3. GUIDE-LINE FOR ERECTION OF ELECTRICAL EQUIPMENT AND ACCESSORIES

7.1.3.1. General

All the electrical equipment shall be installed with proper care and as per layout drawings. Minor modifications required at site shall be made by the contractor with approval of Owner representative/Consultant for installation of the equipment. Care shall be taken for proper handling of equipment and undue vibrations shall be avoided particularly in case of sensitive equipment.

The contractor shall have valid electrical contractor's license valid for State Govt. and as well supervisory licence. He shall have in his employment sufficient number of electricians and supervisors holding valid licenses for HV and LV installations.

7.1.3.2. Rotating machines

The erection work of motors shall include checking of all motors before installation including thorough cleaning and checking of bearings, replacement / rectification of defective items, greasing of bearing, if required, making minor modifications in its mounting arrangement, wherever required, assembling and its mounting on the motor base plate or on Mechanical equipment, as the case may be, including levelling and alignment, checking insulation resistance and improving the same, if necessary, checking of internal connections etc.

All work associated with revisioning of motor shall also be included such as uncoupling and removing of motor from Mechanical equipment, disassembling, cleaning, checking of insulation resistance and improving the same, if necessary, regreasing and replacing defective items/bearings on foundation, wherever required, reassembling, placing, levelling, aligning and fixing of coupling of the revisioned motor with Mechanical equipment.

The height of the shaft of the motors shall correspond to the machine to be driven, if discrepancies are encountered these shall be compensated by inserting machined metal sim plates under the supports of the motor.

The motors mounted on the movable base frames / base plates shall be connected via intermediate terminal boxes with flexible cables.

After the complete installation of the motors, all bolts and bolted joints of the Mechanical and electrical equipment shall be checked to ensure that they are done up tightly by torque wrench. A further check shall be made to ensure that the armature can be easily rotated.

The insulation resistances of the coils and connecting leads within the machine shall be checked against earth by a suitable megger. Insulation resistance if found less, the machine shall be dried to achieve the desired value.

Space heaters of main drive motor required to be installed in motor foundation pits shall be suitably and firmly mounted.

For handling the machine with the crane, the slings, lifting cables etc. shall not be secured around the shaft. However, the armature of disassembled machines may be lifted or supported by the shaft.

The machine shall be lifted or lowered without shocks or quick jerks to avoid any damage.

7.1.3.3. Sheet metal enclosed panels

The base frames of all panels, shall be welded to structures or to the civil inserts provided on the floor/walls. Fabrication of supports/frames, wherever required, shall be done by the contractor.

The shipping section shall be placed in position before removing the protective covering to eliminate scratch/damage. The shipping section shall be moved by using rollers under the shipping skids wherever lifting cranes are not available. The contractor shall do the assembly at site as per manufacturer's general arrangement drawings and installation instruction. While assembling a complete board comprising several unit type cubicles, the board as a whole shall be aligned. The panels shall be properly leveled prior to grouting the holding down bolts or welding the panels to the inserts. All interconnection of bus-bars and wiring between the panels shall be done as per manufacturer's instructions and drawings. Welding work on the panels shall only be carried out after consultation with the Owner. Damage to the paint due to welding shall be rectified by the contractor.

After Mechanical installation of the board is completed, loose instruments shall be installed, wherever required, and wires shall be connected to the instrument. The wiring of intermediate terminal strips between two panels, wherever disconnected for transport, shall also be connected.

7.1.3.4. Transformers

The transformer and its accessories and mountings like conservator, thermometers, sili-cagel breathers, etc., delivered at site in separate packages, shall be assembled at site after cleaning by the contractor in proper sequence as per manufacturer's drawings. The oil conservator and the pipes shall be erected as shown in the manufacturer's drawings.

Before the transformer is filled/topped with oil, oil samples shall be checked by the contractor from each container. The oil shall possess the dielectric strength as per relevant IS/CEA. Oil shall be filled upto the mark shown.

The contractor shall also test the oil from each transformer to determine its suitability for use. If required, the contractor shall carry out drying and filtering operations as per IS code of practice to ensure that moisture is completely removed and the oil is free from impurities. This may be carried out by using oil filtering equipment to be provided by the contractor having vacuum as well as heating arrangement. Only after the dielectric strength of oil and other parameters are checked and approved, the external connections shall be made to the transformers.

Any modifications to HT and LT terminal box to accommodate the number of cables to be

terminated shall be carried out by the contractor.

Naked light and flame shall never be used near the transformer.

7.1.3.5. Cable Installations

Concrete cable channels can be considered in case of lesser number of cables.

Laying of cables directly in underground or in trenches shall be considered where number of cables is less. In such case, cable shall be laid in one layer only, more than one layer is not permissible.

Cables in trenches shall be laid on 8 cm of riddled sand and covered with 8 cm of riddled sand. Red Bricks shall be provided for covering these trenches. The maximum trench depth shall normally be 1.5 m and thickness of top cover of 75 mm.

Installation of cables directly buried in ground shall generally conform to the requirements given in IS: 1255 –1983.

7.1.3.6. HT cable termination accessories

The cable accessories shall include end termination kits and also any special tool and tackles and accessories required for making the terminations.

The termination arrangement shall be complete with all fittings and consumables. For all cables, a minimum extra length of 2 metres shall be left before termination.

The termination kit shall be of heat shrinkable type. The termination kits shall have the following features:

- Electrical stress control to be provided at the cable insulation shield terminus.
- An external leakage insulation to be provided between the cable conductors and ground.
- Adequate protection to be provided at the end of the cables against the entrance of the moisture and, provision to maintain the constant pressure in the cable.

7.1.3.7. Exposed & Concrete conduits

Exposed conduits shall be laid along walls, floors, ceilings, on steel supports etc. as per working drawings/site requirements in consultation with the supervisory personnel. The conduits shall be neatly run and evenly spaced.

Fixing of conduits to the supports on wall, column, structure shall not be done by welding. Exposed conduits shall be adequately supported by racks, clamps, straps etc. Jointing of conduits shall be done only in straight portion and not in bend portion.

The contractor shall have arrangements at site for bending facilities for conduits as well as dies for threading conduits of diameters and threads corresponding to the standards. The threaded ends of conduits shall be painted with anticorrosive paint. The

TENDER NO: GGPL/KKD/C&P/CW/2523/VS

outer ends shall be smoothened free of burrs and sharp edges. Bushings shall be fitted at both ends of conduits.

Flexible metallic conduits shall be used for termination of connections to motors and other electrical equipment like pressure switches etc. which need to be disconnected at periodic intervals.

All conduits shall be effectively connected to the earth terminal of the equipment where it terminates.

Both ends of conduits shall be suitably earthed. Earthing continuity to be maintained by means of flexible wire wherever two conduits are joined with sockets.

Approved conduit bending machines to be arranged by the contractor shall be used for bending conduits at site. The radius of any conduit bend shall be as per standards for cabling. Bends shall be free from cracks, crimps or other damage to the pipe or its coating.

Annular space of used & un-used conduits should be sealed at both ends.

7.1.4. EARTHING AND LIGHTING PROTECTION

7.1.4.1. EARTHING

Entire system shall be earthed in accordance with the provisions of the relevant IEC recommendations/ IS code of practice IS 3043-1987 and Indian Electricity Rules, so that the values of the step and contact potentials in case of faults are kept within safe permissible limits.

Parts of all electrical equipment and machinery not intended to be alive shall have two separate and distinct earth connections each to conform to the stipulation of the Indian Electricity Rules.

All buildings as well as the electrical sub-stations and electrical rooms shall be provided with a ring main earthing system each. Individual ring main earthing systems shall again be interconnected as a network. The earthing system shall be provided to have overall network earthing resistance shall be less than one ohm.

The ring earthing system around each building shall be laid at a distance of approximately 1.5 m from the building and at a depth of approximately 0.8m. The ring shall be bonded at intervals to the building steel structures, reinforcement of building columns and also to pipes, wherever they are crossing. The earth ring shall further be connected at intervals to deep earthing electrodes to achieve a combined earth resistance of less than one ohm.

For the purpose of dimensioning the earthing lines/conductors, the duration of the earth fault current shall be taken as 1 seconds.

TENDER NO: GGPL/KKD/C&P/CW/2523/VS

For protective earthing separate conductor shall be used for flow of earth fault current as elaborated below.

The LV side neutrals of the Distribution transformers & Gas Gen Set shall each be connected to two separate isolated earthing electrodes. They shall also be connected with the neutral bus of the corresponding switchgear and the switchgear neutral bus shall be connected to the earthing ring at two different and distinct points. The fourth core of cables for cables shall also be connected to the earthing mains. A continuous earth strip shall be run in each side of cable trenches.

The power supply cables (LT) from the sub-station and the distribution cables to individual motors shall have 4/3.5 cores.

LT power supply cables shall have four cores and the fourth core shall have cross-sectional area of 50% of the other cores generally. The fourth core of the main supply lines shall be connected to the solidly earthed neutral bar as well as at the earth bars in MCC/distribution boards.

7.1.4.2. CONDUCTOR SIZE FOR GROUND CONNECTIONS

For equipment ground connections, the minimum conductor sizes used should be as follows:

i. LT System:-

75 x 10 mm GI flat :

- Main earthing rings
- Main LT switch-boards
- Transformers
- Gas Gen Set
- Earthing leads to earth electrodes

ii. LT system where the voltage does not exceed 650V normally :

6 Sq.mm Stranded wire :

- Motors and starters upto and including 2.2kW, Light fitting, JBs, etc.
- Instruments and miscellaneous small items protected by fuses of ratings not exceeding 15A.

16 Sq.mm Stranded wire :

- Motors and starters above 3.7 kW and upto including 15 kW.

25 x 3 mm GI Flat :

- Motors and starters above 15 kW and upto including 45 kW.
- LCB, Welding socket outlet, isolators, LDBs.

50 x 6 mm GI Flat :

- Motors and starters over 45 kW and HT maotors.
- MCC, PDB, MLDB.
- Main earthing ring for MCC room, in shop units / plant buildings.
- Cable tryas all around.
- Aux. LT switch board and other equipment protected by circuit breakers.

7.1.4.3. EARTHING ELECTRODES:

The earthing electrodes shall be of GI pipes 50 mm dia and about 4 mm thickness in one piece provided with water holes and other filling devices. Earthing system for computers and microprocessor based equipment/ PCs shall be distinct and separate from the power and lighting equipment earthing system.

Every electrical equipment shall have double earthing.

The earthing grid and the lightning grid shall be interconnected.

7.1.4.4. LIGHTNING PROTECTIN:

All buildings and plant structures vulnerable to lightning strokes owing to their height or exposed situation shall be protected against atmospheric flash-overs and lightning strokes in such a manner as to eliminate any danger to the personnel employed therein. Stipulations of IS : 2309 - 1969 shall be followed.

A 'Faraday Cage' made of hot galvanised strip steel connected to all buried pipes and steel structures crossing this cage ring shall be laid around each main building or plant unit as earthing device. This shall be separate from the electrical equipment earthing ring main.

All lightning arrestor earth leads of the buildings and plant units shall be connected to this cage ring.

Air termination network should cover all salient points of the structure. All metallic chimneys, ducts and the like above the roof of the structure shall be bonded to and form part of the air termination network. Vertical air termination points shall project at least 30 cm above the object on which it is fixed.

Down conductors shall follow the most direct path possible between air termination and earth termination avoiding sharp bends. Down conductor shall have a testing point adjacent to the earth electrode. Each conductor shall have an independent earth termination.

All earth terminations shall be interconnected.

Earthing electrodes and grid for lightning protection shall be distinct separate from the earthing system for earthing of electrical equipment and at no place shall be connected to other earthing system.

Earthing connection to equipment subject to movement, vibration and shocks, shall be through flexible stranded conductors.

The termination of strips to the equipment shall be done by bolting and the wires shall be terminated by compression lugs. Jointing of strips shall be done by welding for proper continuity. All contact surfaces shall be thoroughly cleaned of dust and oil and after jointing, the joints shall be given bitumen paint.

7.1.4.5. GUIDELINES FOR INSTALLTION OF EARTHING CONDUCTOR:

Earthing conductors laid directly in ground for **Lightning protection**, shall be coated with one coat of bituminised paints, be wrapped with one layer of bitumaetic tape laid on half lapped and shall have a final coat of bituminised paint to prevent corrosion.

Earthing conductors run on walls/floors/cable and equipment structures etc. shall be supported at suitable intervals and painted with black oxide paint.

All joints in all kind of Earthing conductors except at earthing electrode shall be welded and painted black with bitumen paint.

At road crossings earthing strips shall be laid through conduits /concrete ducts.

Special earthing shall be provided for all electronic equipment as per manufacturer's recommendations / practice.

8. TESTING:

Test of all equipment shall be conducted as per latest IS applicable. Tests shall also confirm to International Standards IEC/VDE/DIN/BS (in case corresponding test are not mentioned in IS).

All routine test shall be carried out at manufacturer's works in the presence of Owner or his representative.

The tenderer shall submit type test certificates for similar equipment supplied by him elsewhere. In case type test certificates for similar equipment are not available, the same shall be conducted in the presence of Owner or his representative if Owner so desires, without any financial implications to the Owner.

All the equipment shall be tested at site to know its condition and to prove suitability for required performance. The Factory tests, site tests and acceptance tests to be performed by Contractor are detailed below.

The Contractor shall be responsible for satisfactory working of the complete system in an

integrated manner and its guaranteed performance

8.1. TRANSFORMERS:

A. Routine tests

- i. Assembly inspection / painting check.
- ii. Measurement of winding resistance.
- iii. Measurement of voltage ratio and check of voltage vector relationship.
- iv. Measurement of impedance voltage (Principal tapping), short circuit impedance and load loss.
- v. Measurement of no-load and current.
- vi. Measurement of insulation resistance index.
- vii. Dielectric test:
 - a) Induced over voltage withstand test
 - b) Applied voltage withstand test (H.V. power frequency test)
- viii. Certification for off-load tap changer.
- ix. Final documentation check.

B. Type tests

- i. Temperature rise test
- ii. Measurement of acoustic sound level
- iii. Lightning impulse withstand test (if test certificates are not available)
- iv. Short circuit test
- v. Measurement of commutating reactance and determination of inductive voltage drops (for thyristor converter transformer only).

8.2. LT switch gear:

A. Routine tests

- i. Assembly inspection / painting check.
- ii. Measurement of insulation resistance.
- iii. Functional test including automatic bus transfer scheme.
- iv. Polarity tests for CTs
- v. Final documentation check.

B. Type tests

- i. Temperature rise test for main and vertical bus bars.
- ii. Short circuit test for main and vertical bus bars.

- iii. Enclosure calss, degree of protection.
- iv. Dielectric test including protective circuit.

8.3. Final Test of Materials of Grounding and lightning system

- i) Visual check
- ii) Dimensional check
- iii) Accessories fitting check
- iv) Mechanical and electrical test (where applicable)
- v) Final documentation check

8.4. CABLES

A. Shop Tests

- a) The cables shall be subject to shop tests in accordance with relevant standards to prove the design and general qualities of the cables as below:-
- b) Routine test on each drum of cables.
- c) Acceptance tests on drum chosen at random for acceptance of the lot.
- d) High Voltage withstand test for HT cable (Hi Pot test).
- e) Type tests certificates on each type of cable, inclusive of measurement of armour D.C. resistance of power cables shall be furnished by Contractor

B. PACKING

- i. Cables shall suit barrel diameter and securely clamped/fixd. The barrels must be sufficiently strong to withstand Mechanical shocks and shall effectively protect against transit.
- ii. Both ends of cable shall be metal capped to prevent moisture ingress. Ends shall be kept inside the cable drum in a manner so that these are accessible for testing.
- iii. Cable drum identification/markings shall be as follows:
 - a) Makers name
 - b) Consignee's full address
 - c) Type size and length of cables
 - d) Net and gross weights
 - e) Any other marking for shipping

f) Drum Markings

C. Drum Lengths

- i. LT Cables shall be delivered at site preferably on standard drums each containing 500 m or 1000 m cables, Where total quantity of a particular cable is less than 500 m, the entire length shall be supplied in one drum.
- ii. For 90% cable drum of each item of cable permissible tolerance is in length + 5% For 10% balance cable drums, Contractor shall ensure that each 500 m capacity drum contains at least 250m and each 1000m capacity drum contains at least 500m cable lengths. Overall tolerance for each item of cable is + 1% of total length.

8.5. Motors:

A. Routine Tests

The following are the routine tests carried out on each and every motor :

- i. Measurement of resistance.
- ii. Insulation resistance test .
- iii. Motors are tested at 1/3 times the rated voltage for checking the ability of the motor to run upto full speed , when switched in either direction .
- iv. No load test .
- v. High voltage test .

B. Type Tests

- i. Measurement of rotor resistance
- ii. No load test
- iii. Locked rotor test .
- iv. Full load reading of voltage, current , power input and slip.
- v. Temperature rise test.
- vi. Momentary overload test .
- vii. Insulation resistance test .
- viii. High voltage test .
- ix. Polarisation index test (for HT motors)

8.6. SITE TESTS AND CHECKS

8.6.1. General

All the equipment shall be tested at site to know their condition and to prove suitability for required performance.

The test indicated in following pages shall be conducted after installation. All tools, accessories and required instruments shall have to be arranged by contractor. Any other test that is considered necessary by the manufacturer of the equipment, Contractor or mentioned in commissioning manual has to be conducted at site.

TENDER NO: GGPL/KKD/C&P/CW/2523/VS

In addition to tests on individual equipment some tests / checks are to be conducted / observed from overall system point of view. Such checks are highlighted under miscellaneous tests but these shall not be limited to as indicated and shall be finalised with consultation of Owner before charging of the system.

The Contractor shall be responsible for satisfactory working of complete integrated system and guaranteed performance.

All checks and tests shall be conducted in the presence of Owner's representative and test results shall be submitted in six copies to Owner and one copy to Electrical Inspector. Test results shall be filled in proper proforma.

After clearance from Electrical Inspector, system / equipment shall be charged in step by step method.

Based on the test results clear cut observation shall be indicated by testing engineer with regard to suitability for charging of the equipment or reasons for not charging are to be brought by the Contractor.

8.6.2. Trial Run Test

After the successful test of each equipment as per standard test procedure, the entire control system shall be put on trial run test on actual site conditions and operation of the system.

8.6.3. Acceptance Test

The acceptance test on the system shall be carried out by the contractor as per mutually agreed test procedures to establish satisfactorily functioning of the system as a whole and each equipment as part of the system.

8.6.4. Site tests

The tests to be carried out on the equipment at pre-commissioning stage shall include following but not limited to the following:

Transformer:

- i. IR test on each winding to ground and between winding.
- ii. HV test with 2.5 KV megger for HV side and 500V for LV side.
- iii. BDV test on oil samples.

LT switch board

- i. IR test.
- ii. HV test with 2.5 KV megger.
- iii. Functional test for all feeders.
- iv. Check operation of contactors from local points.

CABLES

TENDER NO: GGPL/KKD/C&P/CW/2523/VS

- i. Visual check.
- ii. Checking of continuity and IR values for all the cables before and after HV test.
- iii. HV test and measurement of leakage current after termination of cable kits.
- iv. Check for identification (tag number system) distance placement of cable marker, cable joint etc. as per the cable layout drawing.
- v. Check tightness of all connections.

EARTHING

- i. Check tightness of all earth connections.
- ii. Check earthing of all metallic equipment, cable trays, busbar supporting structures, building column (if steel) all elect equipment, pipe lines etc. as per the drawing / specification.
- iii. Measurement of earth resistance for each electrode
- iv. Measurement of total earth resistance.

MISCELLANEOUS

- i. Checking of continuity of the system.
- ii. Checking safe accessibility of all operating points.
- iii. Check availability of emergency lighting.
- iv. Check availability of control aux. supply.
- v. Ensure availability of first aid box, fire fighting equipment, rubber mats, rubber glove.
- vi. Check for safe movement of operators control room / switchgear etc., wrt proper illumination, escape light uncovered openings provision of hand railings in stairs etc.
- vii. Check proper covering of cable channels.
- viii. Placement of shock treatment chart, danger boards provision of boards indicating 'Man on work' 'Do not switch ON' 'Do not switch OFF'. 'EARTHED' etc.
- ix. Check proper dressing of cables, Mechanical protection of cables, placement of cable markers.
- x. Check sealing of all cable openings including conduits opening with fire resistance material.
- xi. Check sealing of all openings at bottom of electrical panels.

PREFERRED MAKE LIST

S.No	ITEM DESCRIPTION	PREFERRED MAKES
1	11/0.433kV Distribution transformer	Viji Power Transformers Pvt. Limited/Flow Line transformers Pvt. Ltd/Diamond Power Transformer/Mahalakshmi transformers / Kavika transformer/Techno Fabs/Voltech Manufacturing Company Limited/Perfect Electricals
2	11kV Termination Kit	3M/RAYCHEM/CCI
3	HT XLPE Cables	Universal/Polycab/KEI/KEC
4	LT Power Cable (FRLS)	Universal/Polycab/KEI/KEC/Special CABLES
5	LT Switchgear	ABB/C&S/BCH/Risha Control Engineering Pvt. Limited/Siemens/Lotus Power Gear
6	Flame proof light fixtures	Baliga/ Sudhir Switchgears Pvt. Ltd./ Flexpro Electricals Pvt. Ltd./ FCG./ Bajaj Electricals Ltd./ Crompton Greaves Ltd.
7	Non Flame proof Light Fixtures	Bajaj/Crompton/Wipro/Philips/Osram/Sigma
8	High Mast/Street Light Poles	Philips/Bajaj/CGL/Wipro/Transrail/Tulip
9	Air Conditioner	O General/ Daikin/ Hitachi
10	FLP Cable glands	Baliga/ Flexpro/ Flameproof/ FCG/Dowells
11	Cable - Lugs	Dowells/ Jainson

TENDER NO: GGPL/KKD/C&P/CW/2523/VS

12	Cable tray	Advance power product/Ercon Composite /India Electricals Syndicate/Mahavir Engineering
13	Ceiling/Exhaust Fans	Khaitan Electricals Ltd./ Havell's/ Crompton Greaves Limited/Bajaj Electricals/USHA
14	Contactors - AC Power	ABB/Siemens/Schneider/L&T/Control and switchgear
15	Control Transformer	Intravidyut/Indcoil/Kappa/Kalpa/Indushree
16	Earthing Materials	Rukmani Electrical & Components Pvt Ltd./ Indiana Grating Pvt Ltd./Any reputed make with ISI certification
17	Flame proof LDB's/ JB,s/Control Station/ switches	FCG/Flame proof/Flexpro Electricals/Sudhir/ Baliga Lighting Equipments Pvt. Ltd.
18	Indicating Lamps	Vaishno Electricals/Osram/TelePMChanique/ABB/Esbee/Essen
19	Indicating Meters	Conzerv(Schneider)/ Rishabh Instruments Pvt. Ltd./ AE/PMCO/Secure meters/ABB/Siemens
20	Miniature Circuit Breakers (MCBs) and Lighting DB	Siemens/L&T/Schneider/Indoasian/Havells/MDS(Legrand)/ABB/HPL India
21	MCCB	Siemens/L&T/Schneider/ABB
22	Protection Relays - Thermal	BCH/L&T/Schneider/Siemens/ABB/Control & Switchgear
23	Push Buttons	Salzer/BCH/L&T/Essen/Technic/Vaishno/ABB/Control & Switchgear
24	Selector switches	ABB/BCH/Kaycee/Siemens/Teknik/L&T/Control & Switchgear/Vaishno/Salzer/Siemens
25	Switches - 5/15A Piano/ Plate, Switch Socket	Anchor/MDS Legrand/Precision/Cona
26	Switch Socket Outlet	Anchor/BCH/Essen/Best & Crompton

TENDER NO: GGPL/KKD/C&P/CW/2523/VS

27	Switch Socket Outlets (Industrial)	Essen Engineering Company Pvt. Ltd./ Crompton Greaves Ltd./ BCH
28	GI Pipes	Tata Pipe/Jindal/GSI/Indus Tube/Swatik/Zenith
29	PVC pipes	Finolex/Premier/Sudhakar/Kissan/Supreme
30	Safety Items – Shock treatment chart etc	Reputed make with ISI certification
31	Terminal Blocks	Phoenix Contact/ Connect Well/Lapp/ S&S/ Wago /Elmex
32	Timer & Time delay relays	ABB/BCH/L&T/Siemens / Essen/TelePMCanique/Omron
33	ELCB/RCCB	ABB/Siemens/Schneider/MDS (Legrand)/L&T/Indoasian/HPL India

LIST OF STANDARD DRAWINGS

Sl No.	Description	Document No./ Drawing No.	Rev.
1	SLD for PDB Panel for CNG station	PMC/23RT /01/E1/D2/CN/ST/0413	Rev. 0
2	SLD for Emergency Panel	PMC/23RT /01/E1/D2/CN/ST/0414	Rev. 0
3	SLD of LDB-1	PMC/23RT /01/E1/D2/CN/ST/0415	Rev. 0
4	SLD of LDB-2	PMC/23RT /01/E1/D2/CN/ST/0416	Rev. 0
5	SLD of LDB-3	PMC/23RT /01/E1/D2/CN/ST/0417	Rev. 0
6	Marking of trenches for electric cables	PMC/23RT /01/E1/D2/CN/ST/0418	Rev. 0
7	Typical Installation of Street Lighting Fixtures (Bracket Mounted) on pole for safe area	PMC/23RT/01/E1/D2/CN/ST/0419	Rev. 0
8	Typical section of cable trench in unpaved areas	PMC/23RT/01/E1/D2/CN/ST/0420 (2 Sheets)	Rev. 0
9	Typical installation of lighting fixture on octagonal pole	PMC/23RT/01/E1/D2/CN/ST/0421 (Sheet 1 to 3)	Rev. 0
10	Flame proof lighting fixture mounting details	PMC/23RT/01/E1/D2/CN/ST/0424	Rev. 0
11	Typical installation of flood lighting pole(with rungs)	PMC/23RT/01/E1/D2/CN/ST/0425	Rev. 0
12	Earthing of tanks and vessels	PMC/23RT/01/E1/D2/CN/ST/0427	Rev. 0
13	Typical earth connection for street light pole	PMC/23RT/01/E1/D2/CN/ST/0428	Rev. 0
14	Typical installation of lighting fixture on octagonal pole	PMC/23RT/01/E1/D2/CN/ST/0429	Rev. 0
15	Earth electrode in test pit	PMC/23RT/01/E1/D2/CN/ST/0430	Rev. 0
16	Typical Electrical Earth pit	PMC/23RT/01/E1/D2/CN/ST/431	Rev. 0
17	Typical Electronic Earth pit	PMC/23RT/01/E5/D2/CN/ST/001	Rev. 0

TENDER NO: GGPL/KKD/C&P/CW/2523/VS

CHECK LIST

TO BE FILLED-UP BY TENDERER

Sl. No.	Description	Remarks
1.	No deviation from the Electrical Specification/SOR	
2.	Confirmation for Inspection of all electrical equipments as per Specification/QAP.	
3.	Unpriced SOR enclosed with offer	
4.	List of similar electrical job undertaken during last three years has been enclosed with the offer.	
5.	List of electrical personnel employed, with their qualification & experience, has been enclosed with the offer.	
6.	Credential of electrical sub-contractor, enclosed with the offer.	
7.	Photocopy of Electrical Contractor's license - grade A has been enclosed with the offer.	

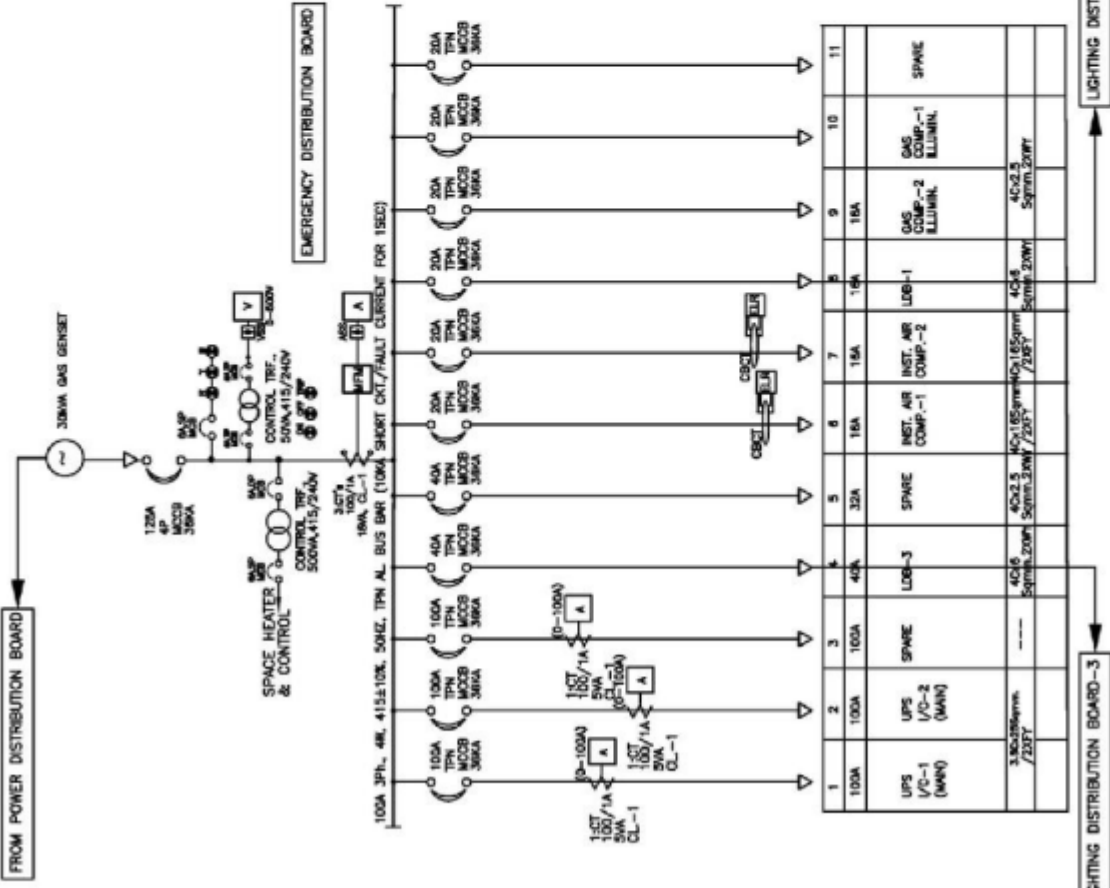

SYMBOLS

SYMBOL	DESCRIPTION	SYMBOL	DESCRIPTION	SYMBOL	DESCRIPTION
(C)	MOVING	(C)	D.C. RELAY	(I)	UPPING HOOKS
(M)	MARKER	(A)	NO CONTACT OF	(M)	STARTING STOP
(A)	AMMETER	(P)	STOP PUSH BUTTON	(C)	CAPACITOR
(V)	VOLTMETER	(S)	START PUSH BUTTON	(D)	DOUBLE WY
(S)	SELECTOR SWITCH	(L)	METAL LINK	(T)	DISTRIBUTION TRANSFORMER
(P)	FUSE BUTTON	(T)	TERMINAL		
(I)	INDICATING LIGHT	(C)	CHANGE OVER SWITCH		
(L)	RED LIGHT WITH P.B.	(C.T.)	C. T.		
(C)	WIRE/COIL	(R)	RESISTOR		
(C)	FUSE/WIRE/COIL	(C)	CONDUCTOR COIL		
(C)	MCB	(T)	TIMER		
(F)	FUSE	(O)	TRIP OPEN ON DELAY		
(C)	NO CONTACT	(C)	TRIP CLOSED ON DELAY		
(C)	NO CONTACT	(T)	500A DCRA TIMER		

FOR TENDER PURPOSE

**SINGLE LINE DIAGRAM
EMERGENCY PANEL**

DESIGNED BY	DATE	SCALE
CHECKED BY	DATE	SCALE
APPROVED BY	DATE	SCALE

NO.	REV.	DATE	DESCRIPTION

NO.	REV.	DATE	DESCRIPTION

NO.	REV.	DATE	DESCRIPTION

NO.	REV.	DATE	DESCRIPTION

NO.	REV.	DATE	DESCRIPTION

FROM POWER DISTRIBUTION BOARD

TO LIGHTING DISTRIBUTION BOARD-1

TO LIGHTING DISTRIBUTION BOARD-3

CONTRACT NO.

11

12

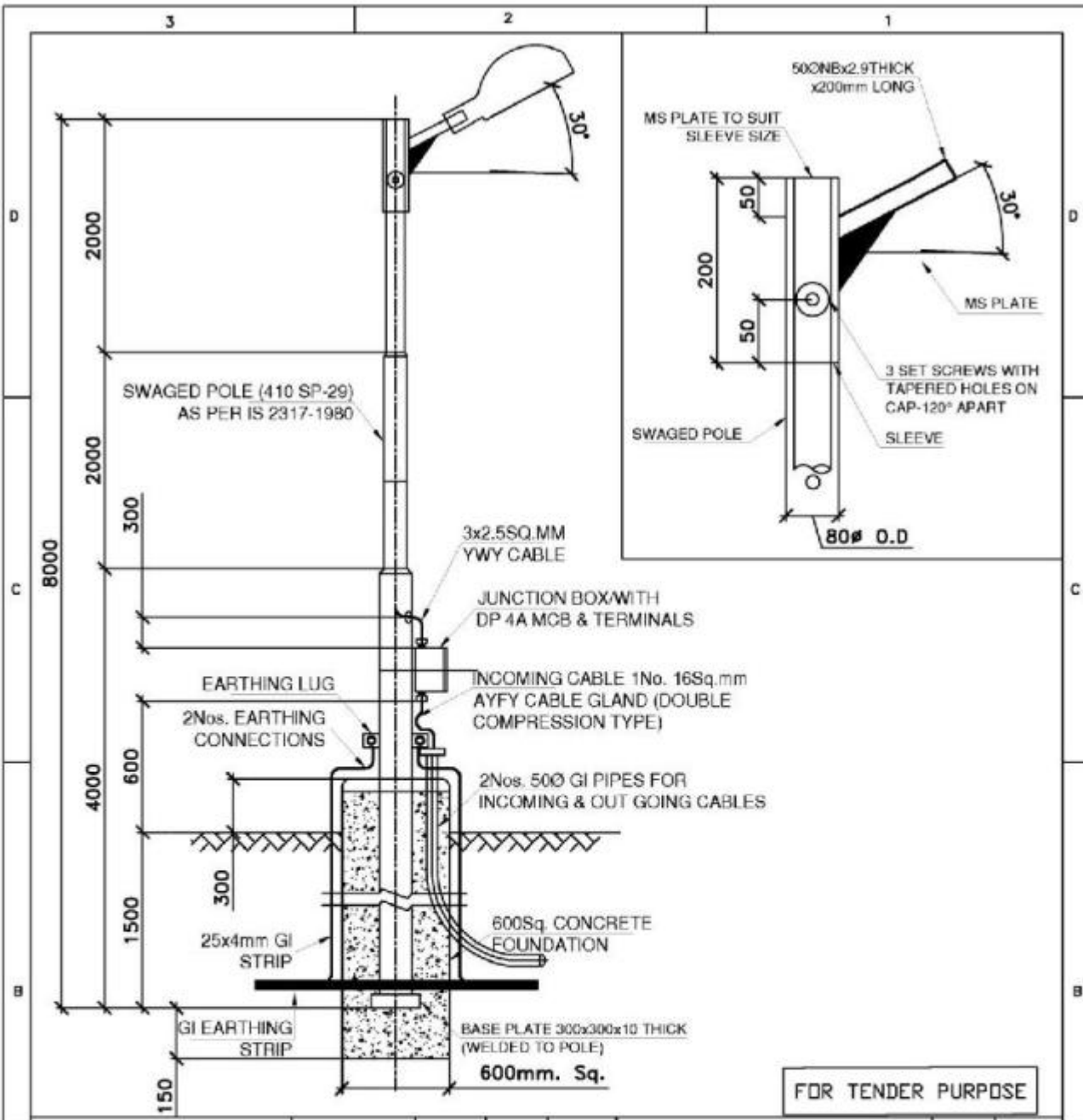

FOR TENDER PURPOSE

REFERENCES	DRG.No.	REV.No.	ZONE	DATE	DESCRIPTION OF REVISIONS	BY	APPRD.
NOTE:							

©2014 MECON LIMITED. ALL RIGHTS RESERVED.
 THIS DRAWING IS THE PROPERTY OF MECON AND IS ISSUED FOR THE SPECIFIC PROJECT MENTIONED THEREIN. THIS IS NOT TO BE COPIED OR USED FOR OTHER PROJECTS UNLESS EXPRESSLY PERMITTED BY MECON.

NAME	SIGN. & DATE	SECTION :
DESIGNED	MADHU	ELECTRICAL
CAD	RAGHU	SCALE : NTS
REVIEWED	S.C	SH.No. 1 of 1
APPROVED	S.C	

TYPICAL INSTALLATION OF STREET LIGHTING FIXTURES (BRACKET MOUNTED) ON POLE FOR SAFE AREA

DRG.No. : MEC/23RT/01/E1/D2/CN/ST/0419

3

2

1

TYPICAL SECTION WITH H.T CABLES AND L.T CABLES FINISHED GRADE LEVEL

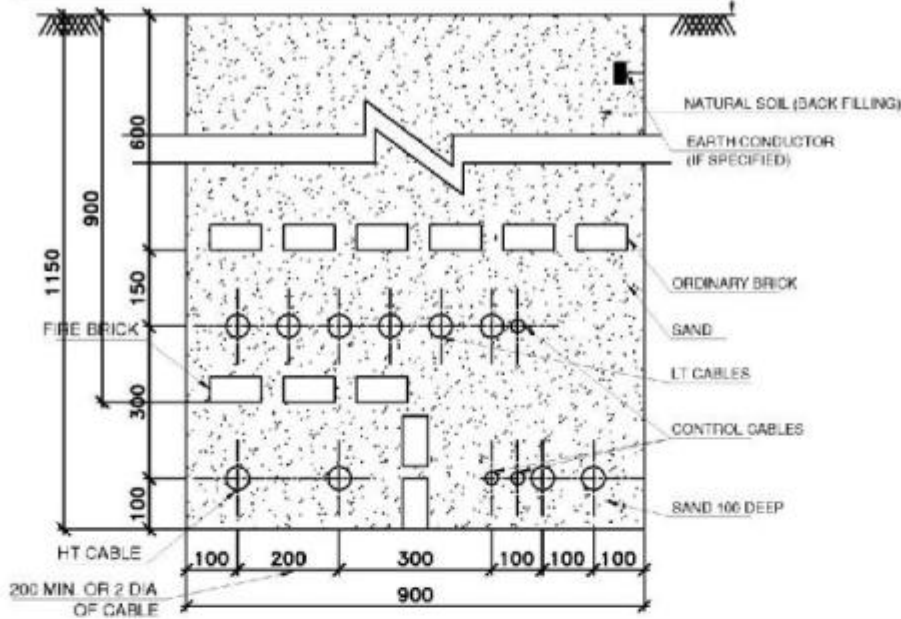

TYPICAL SECTION WITH L.T CABLES ONLY FINISHED GRADE LEVEL

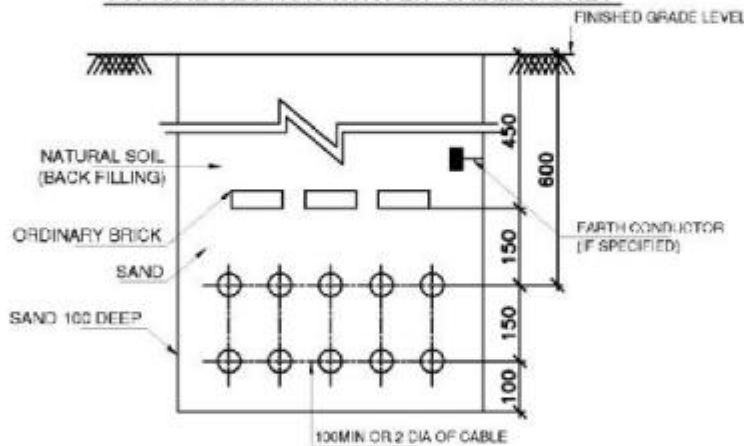

NOTE:

1. LEAVE SPACE FOR LATER ADDITION OF AT LEAST 2 CABLES OR 15% AVERAGE SPARE SPACE REGARDLESS OF FUTURE EXPANSION.
2. IF TELEPHONE CABLES ARE LAID IN THE SAME TRENCH A CLARENCE OF 300mm SHALL BE PROVIDED BETWEEN POWER AND TELEPHONE CABLES.

FOR TENDER PURPOSE

REFERENCES	DRG.No.	REV.No.	ZONE	DATE	DESCRIPTION OF REVISIONS	BY	APPRD.
NOTE:							

©2014 MECON LIMITED. ALL RIGHTS RESERVED.
 THIS DRAWING IS THE PROPERTY OF MECON AND IS ISSUED FOR THE SPECIFIC PROJECT MENTIONED THEREIN. THIS IS NOT TO BE COPIED OR USED FOR OTHER PROJECTS UNLESS EXPRESSLY PERMITTED BY MECON.

	NAME	SIGN. & DATE	SECTION :
DESIGNED	MADHU	<i>[Signature]</i>	ELECTRICAL
CAD	RAGHU		SCALE : NTS
REVIEWED	S.C	<i>[Signature]</i>	SH.No. 1 of 1
APPROVED	S.C	<i>[Signature]</i>	

TYPICAL SECTION OF CABLE TRENCH IN UNPAVED AREAS

DRG.No. : MEC/23RT/01/E1/D2/CN/ST/0420

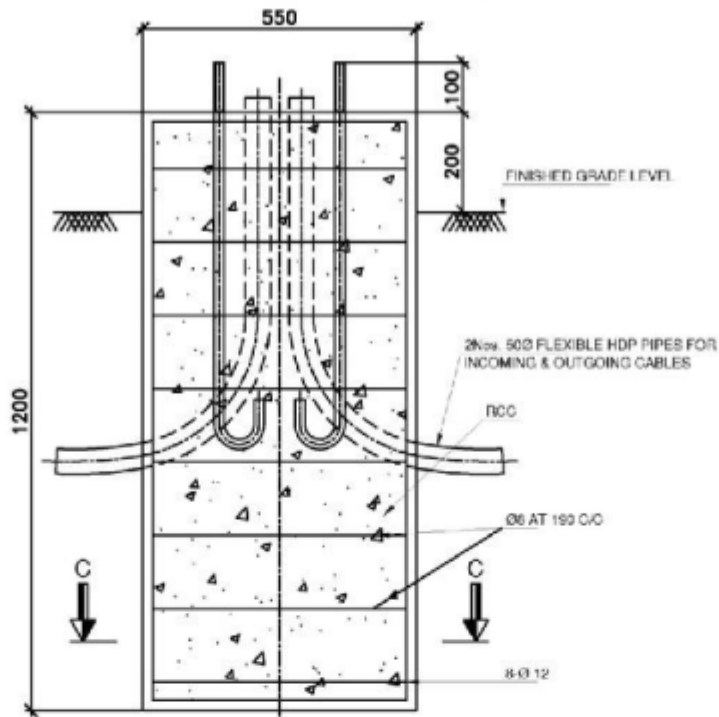

DETAIL OF CIVIL FOUNDATION

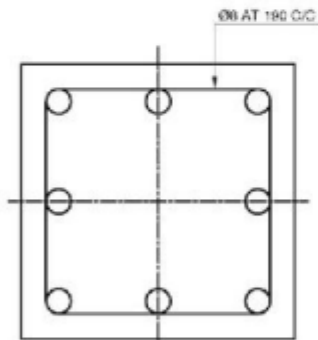

SECTION C-C

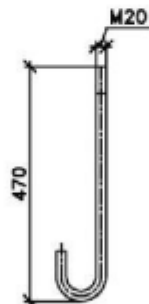

ANCHOR BOLT DETAILS

(TOTAL LENGTH 800mm)

NOTE:-

1. GRADE OF STEEL REINFORCEMENT (FOR R.C.C)-FE 415
2. CLEAR COVER TO REINFORCEMENT-50mm
3. ASSUMED 5 B.C-10T/Sq.m. (MINIMUM)

FOR TENDER PURPOSE

REFERENCES	DRG.No.	REV.No.	ZONE	DATE	DESCRIPTION OF REVISIONS	BY	APPRD.
NOTE:							

©2014 MECON LIMITED. ALL RIGHTS RESERVED.

THIS DRAWING IS THE PROPERTY OF MECON AND IS ISSUED FOR THE SPECIFIC PROJECT MENTIONED THEREIN. THIS IS NOT TO BE COPIED OR USED FOR OTHER PROJECTS UNLESS EXPRESSLY PERMITTED BY MECON.

	NAME	SIGN. & DATE	SECTION :
DESIGNED	MADHU	<i>[Signature]</i>	ELECTRICAL
CAD	RAGHU	<i>[Signature]</i>	SCALE : NTS
REVIEWED	S.C	<i>[Signature]</i>	SH.No. 1 of 3
APPROVED	S.C	<i>[Signature]</i>	

TYPICAL INSTALLATION OF LIGHTING FIXTURE ON OCTAGONAL POLE

DRG.No. : MEC/23RT/01/E1/D2/CN/ST/0421

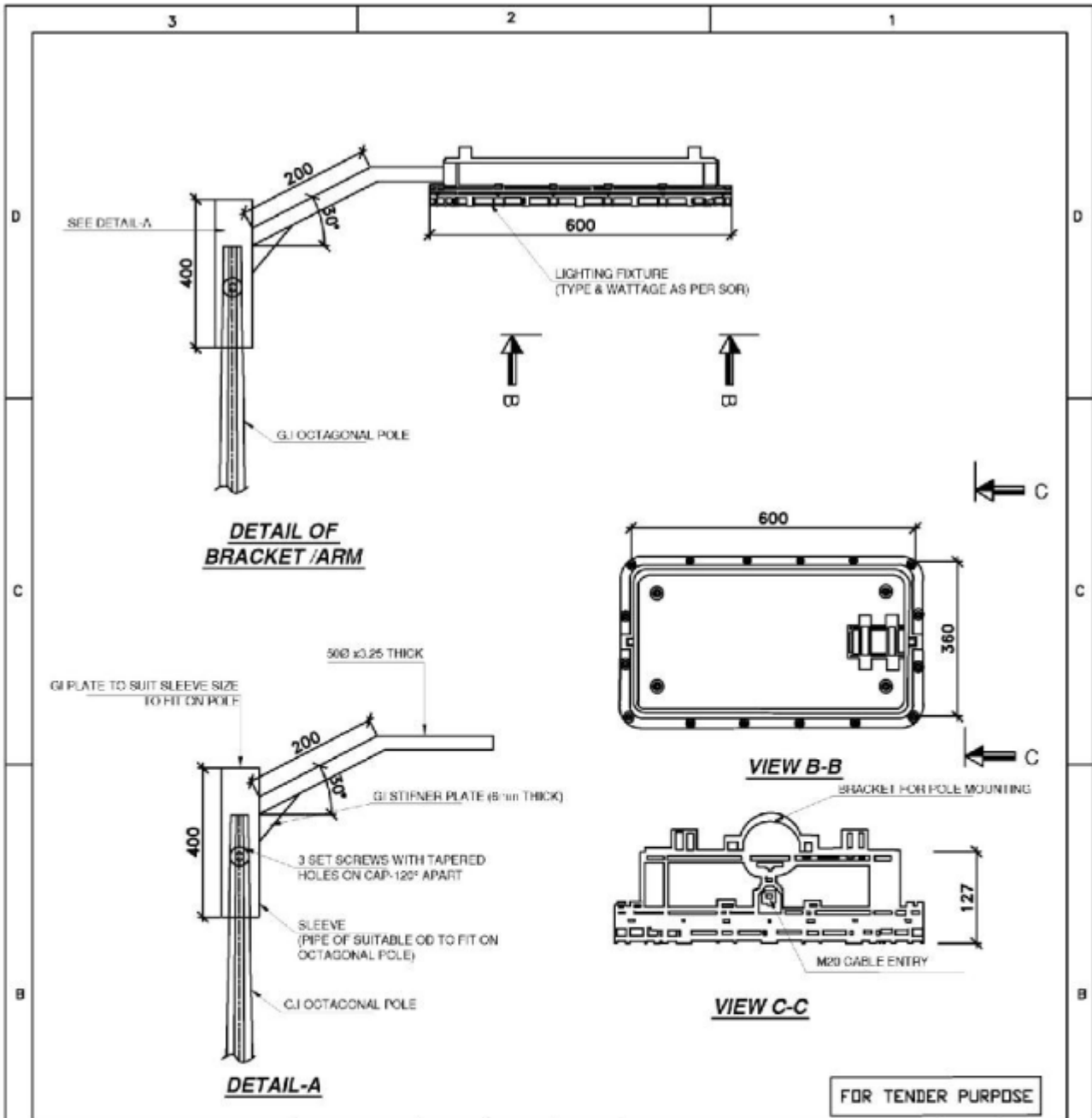

FOR TENDER PURPOSE

REFERENCES	DRG.No.	REV.No.	ZONE	DATE	DESCRIPTION OF REVISIONS	BY	APPRD.
------------	---------	---------	------	------	--------------------------	----	--------

NOTE:
 ©2014 MECON LIMITED. ALL RIGHTS RESERVED.

THIS DRAWING IS THE PROPERTY OF MECON AND IS ISSUED FOR THE SPECIFIC PROJECT MENTIONED THEREIN. THIS IS NOT TO BE COPIED OR USED FOR OTHER PROJECTS UNLESS EXPRESSLY PERMITTED BY MECON.

	NAME	SIGN. & DATE	SECTION :
DESIGNED	MADHU	<i>[Signature]</i>	ELECTRICAL
CAD	RAGHU	<i>[Signature]</i>	SCALE : NTS
REVIEWED	S.C	<i>[Signature]</i>	SH.No. 2 of 3
APPROVED	S.C	<i>[Signature]</i>	

TYPICAL INSTALLATION OF LIGHTING FIXTURE ON OCTAGONAL POLE

DRG.No. : MEC/23RT/01/E1/D2/CN/ST/0421

3

2

1

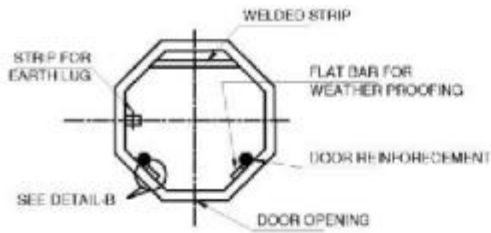

**SECTION A-A
(FOR SAFE AREA)**

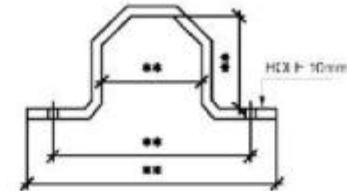

**G.I MOUNTING CLAMPS FOR
CONTROL GEAR BOX**

NOTE:-

1. * DIMENSION TO FIT THE MOUNTING HOLE OF CONTROL GEAR BOX.
2. ** TO SUIT POLE DIMENSION

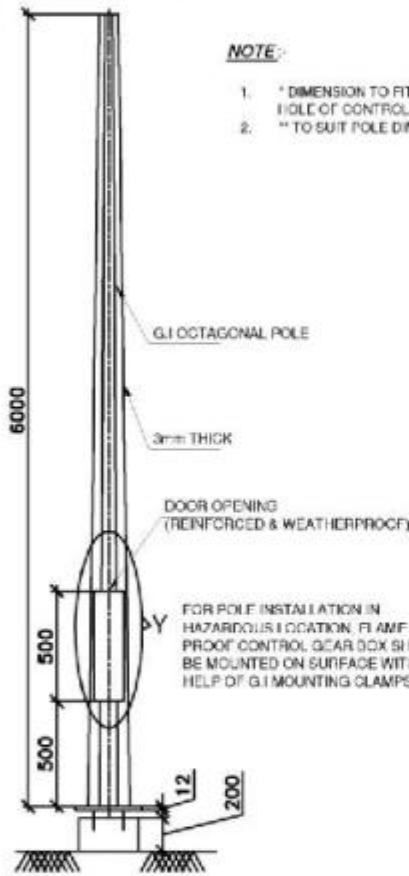

ELEVATION

FOR POLE INSTALLATION IN HAZARDOUS LOCATION, FLAME PROOF CONTROL GEAR BOX SHALL BE MOUNTED ON SURFACE WITH THE HELP OF G.I MOUNTING CLAMPS

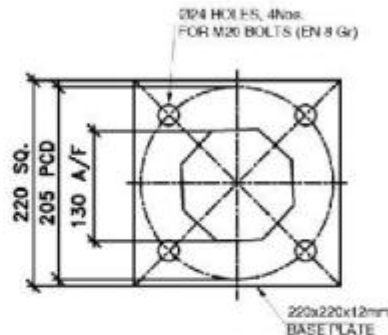

BASE PLATE

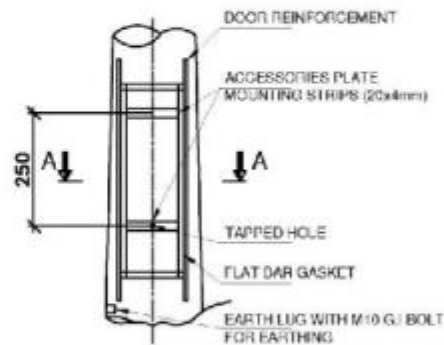

DETAIL - Y

FOR TENDER PURPOSE

REFERENCES	DRG.No.	REV.No.	ZONE	DATE	DESCRIPTION OF REVISIONS	BY	APPRD.
NOTE:							

©2014 MECOM LIMITED. ALL RIGHTS RESERVED.

THIS DRAWING IS THE PROPERTY OF MECOM AND IS ISSUED FOR THE SPECIFIC PROJECT MENTIONED THEREIN. THIS IS NOT TO BE COPIED OR USED FOR OTHER PROJECTS UNLESS EXPRESSLY PERMITTED BY MECOM.

	NAME	SIGN. & DATE	SECTION :
DESIGNED	MADHU		ELECTRICAL
CAD	RAGHU		SCALE : NTS
REVIEWED	S.C		SH.No. 3 of 3
APPROVED	S.C		

**TYPICAL INSTALLATION OF LIGHTING FIXTURE
ON OCTAGONAL POLE**

DRG.No. : MEC/23RT/01/E1/D2/CN/ST/0421

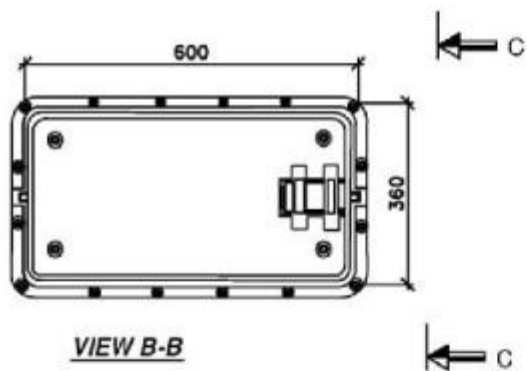

**DETAIL-1
(ADAPTOR)**

DESCRIPTION	DIMENSIONS	
	X	Y
PLATFORM MOUNTED POLE	TO SUIT 190 B.S PIPE	TO SUIT 380 B.S PIPE
FLOOR MOUNTED POLE	TO SUIT 190 B.S PIPE	TO SUIT 500 B.S PIPE

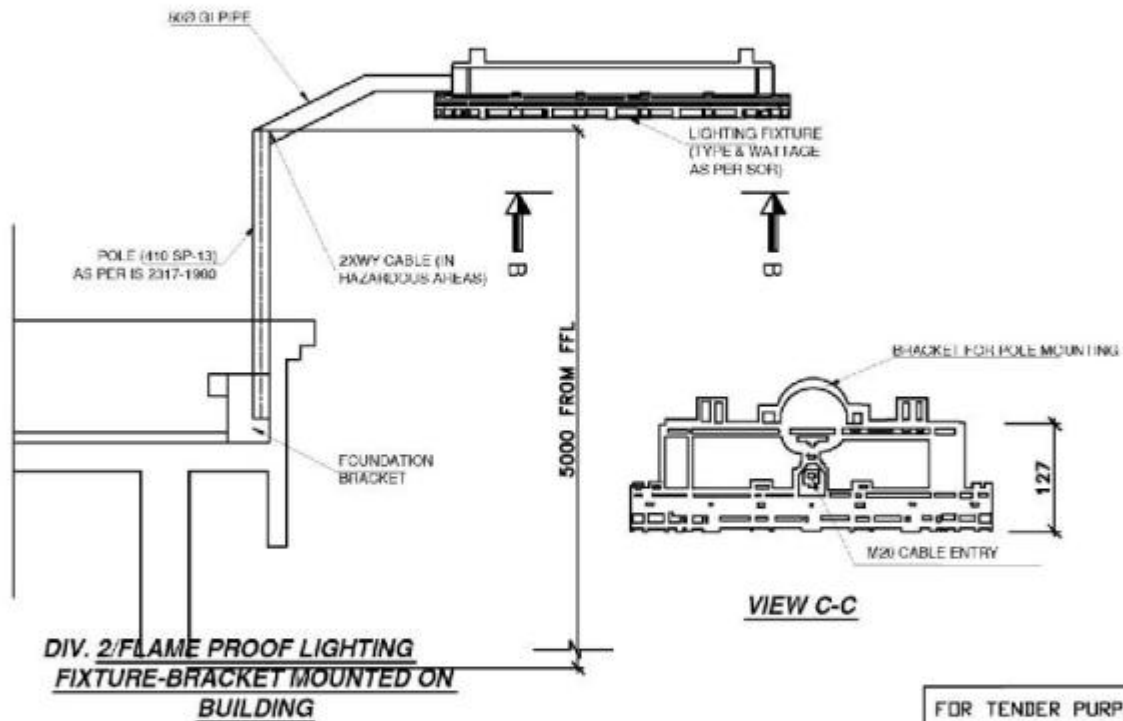

**DIV. 2/FLAME PROOF LIGHTING
FIXTURE-BRACKET MOUNTED ON
BUILDING**

FOR TENDER PURPOSE

REFERENCES	DRG.No.	REV.No.	ZONE	DATE	DESCRIPTION OF REVISIONS	BY	APPRD.
NOTE:							

©2014 MECON LIMITED. ALL RIGHTS RESERVED.
 THIS DRAWING IS THE PROPERTY OF MECON AND IS ISSUED FOR THE SPECIFIC PROJECT MENTIONED THEREIN. THIS IS NOT TO BE COPIED OR USED FOR OTHER PROJECTS UNLESS EXPRESSLY PERMITTED BY MECON.

	NAME	SIGN. & DATE	SECTION :
DESIGNED	MADHU	<i>[Signature]</i>	ELECTRICAL
CAD	RAGHU	<i>[Signature]</i>	SCALE : NTS
REVIEWED	S.C	<i>[Signature]</i>	SH.No. 1 of 1
APPROVED	S.C	<i>[Signature]</i>	

**FLAME PROOF LIGHTING FIXTURE MOUNTING DETAILS
(TYPICAL)**

DRG.No. : MEC/23RT/01/E1/D2/CN/ST/0424

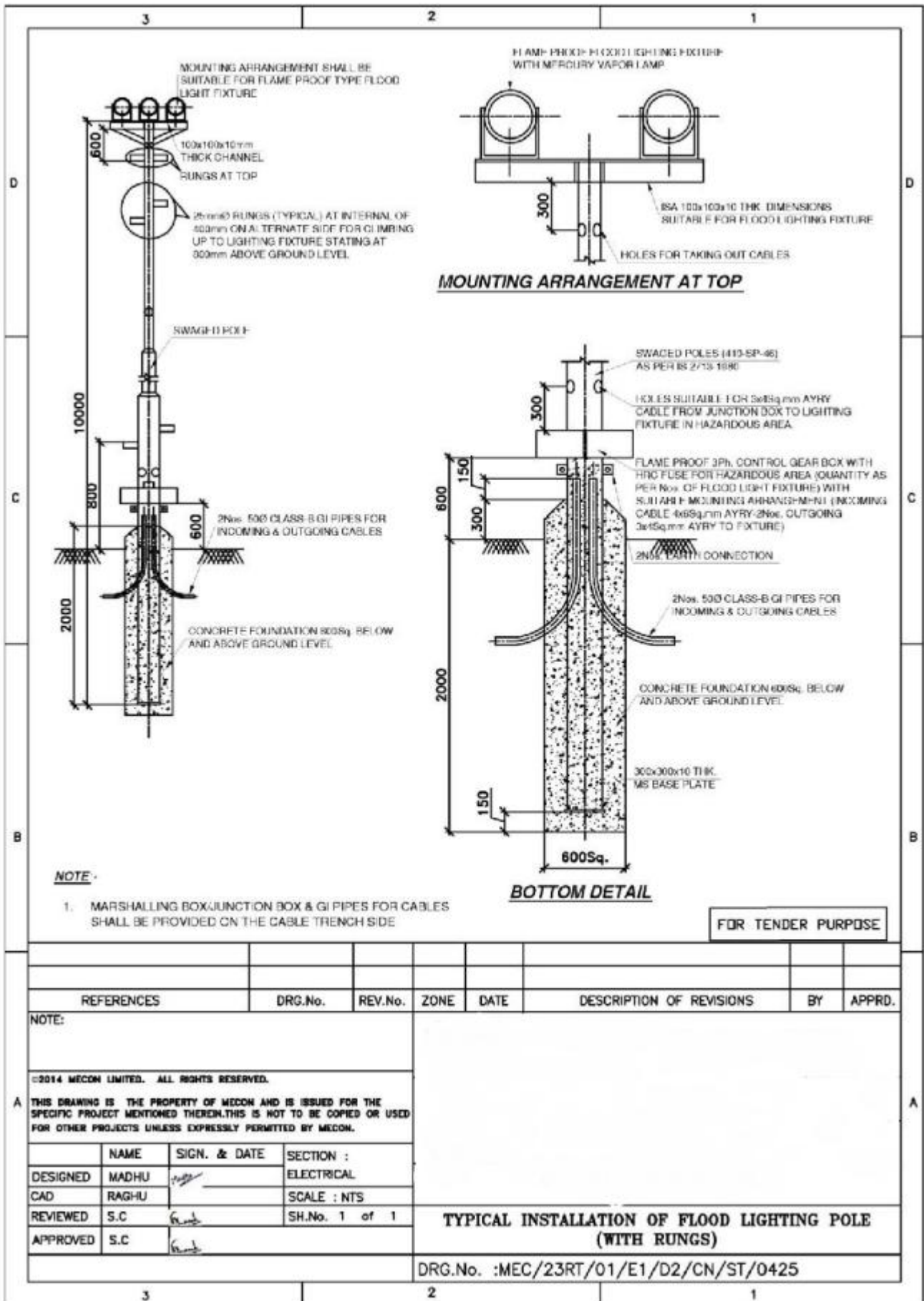

REFERENCES	DRG.No.	REV.No.	ZONE	DATE	DESCRIPTION OF REVISIONS	BY	APPRD.
NOTE:							

©2014 MECON LIMITED. ALL RIGHTS RESERVED.

THIS DRAWING IS THE PROPERTY OF MECON AND IS ISSUED FOR THE SPECIFIC PROJECT MENTIONED THEREIN. THIS IS NOT TO BE COPIED OR USED FOR OTHER PROJECTS UNLESS EXPRESSLY PERMITTED BY MECON.

	NAME	SIGN. & DATE	SECTION :
DESIGNED	MADHU	<i>[Signature]</i>	ELECTRICAL
CAD	RAGHU	<i>[Signature]</i>	SCALE : NTS
REVIEWED	S.C	<i>[Signature]</i>	SH.No. 1 of 1
APPROVED	S.C	<i>[Signature]</i>	

TYPICAL INSTALLATION OF FLOOD LIGHTING POLE (WITH RUNGS)

DRG.No. : MEC/23RT/01/E1/D2/CN/ST/0425

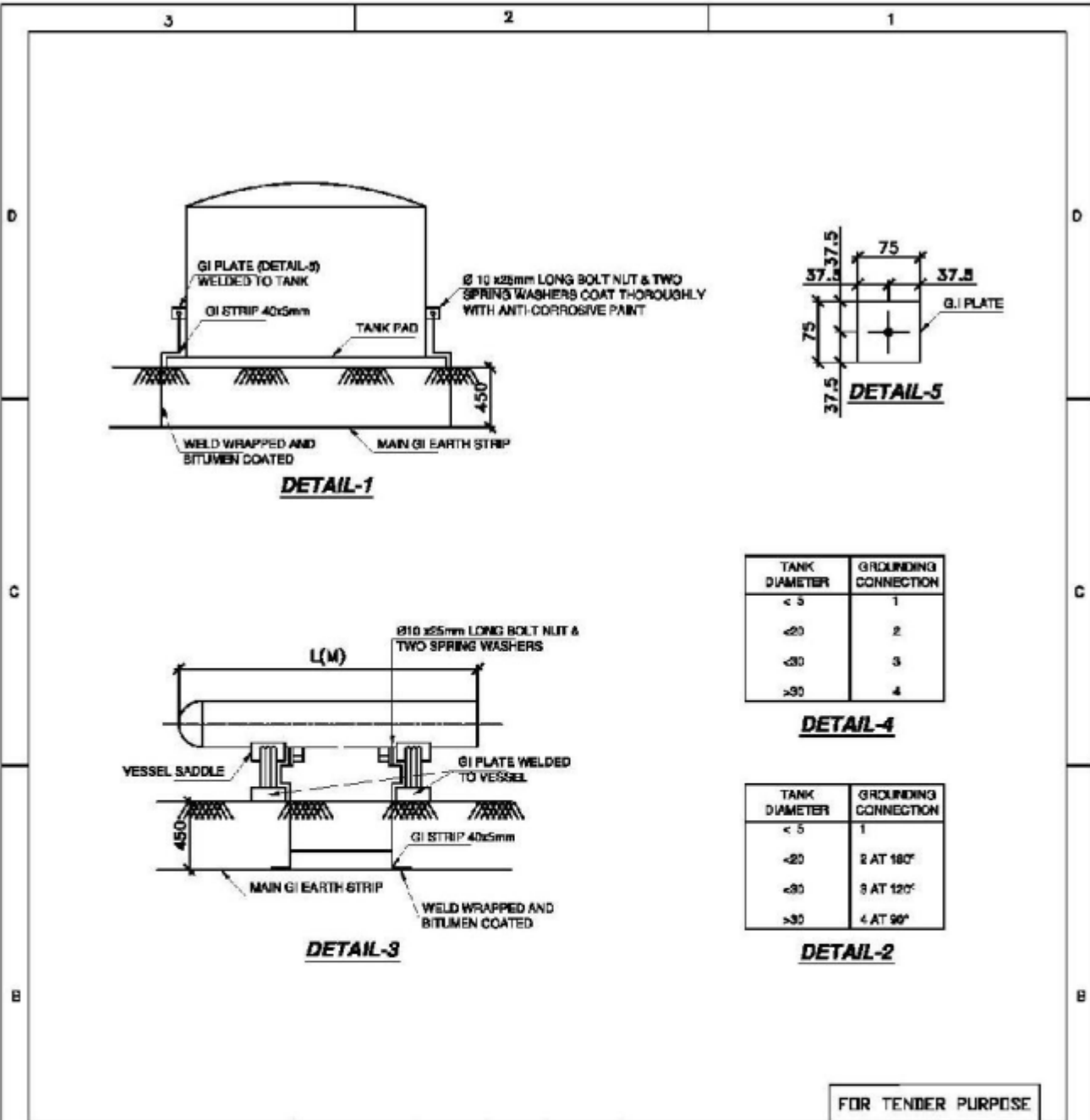

TANK DIAMETER	GROUNDING CONNECTION
< 5	1
<20	2
<30	3
>30	4

DETAIL-2

TANK DIAMETER	GROUNDING CONNECTION
< 5	1
<20	2 AT 180°
<30	3 AT 120°
>30	4 AT 90°

DETAIL-4

FOR TENDER PURPOSE

REFERENCES	DRG.No.	REV.No.	ZONE	DATE	DESCRIPTION OF REVISIONS	BY	APPRD.

NOTE:

©2014 MEDON LIMITED. ALL RIGHTS RESERVED.
 THIS DRAWING IS THE PROPERTY OF MEDON AND IS ISSUED FOR THE SPECIFIC PROJECT MENTIONED THEREIN. THIS IS NOT TO BE COPIED OR USED FOR OTHER PROJECTS UNLESS EXPRESSLY PERMITTED BY MEDON.

NAME	S/GN. & DATE	SECTION :
DESIGNED	MADHU	ELECTRICAL
CAD	RAGHU	SCALE : NTS
REVIEWED	S.C	SH.No. 1 of 1
APPROVED	S.C	

EARTHING OF TANKS AND VESSELS

DRG.No. : MEC/23RT/01/E1/D2/CN/ST/0427

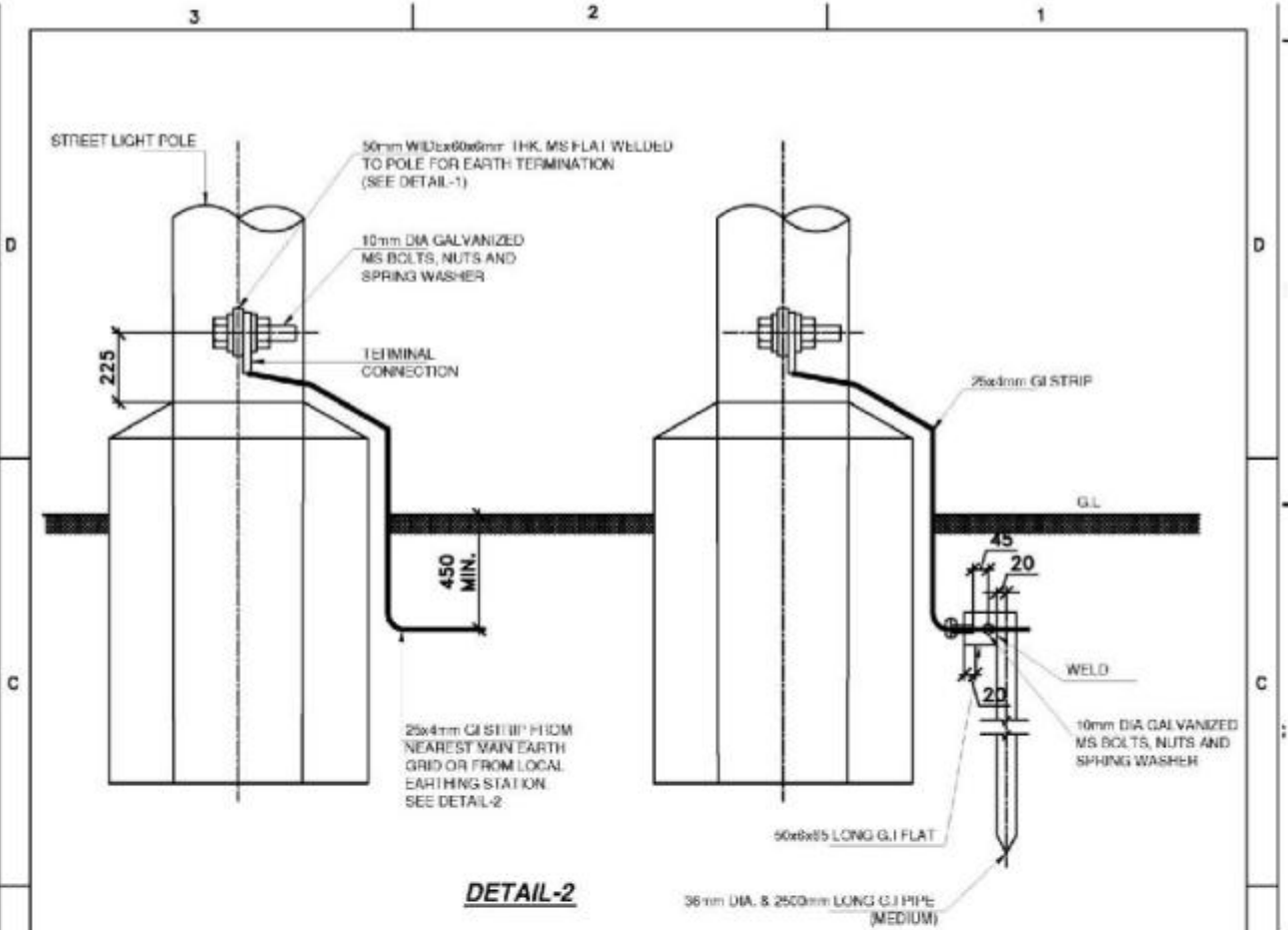

DETAIL-2

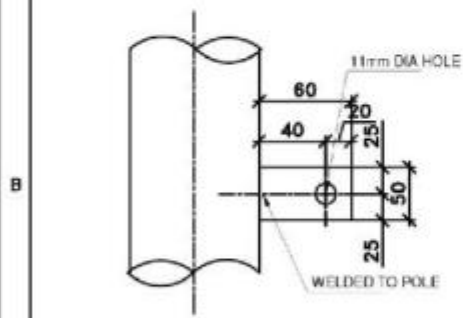

DETAIL-1

NOTE -

- 1. USE TWO EARTHING'S IF VOLTAGE IN POLE JUNCTION BOX IS 415V.

FOR TENDER PURPOSE

REFERENCES	DRG.No.	REV.No.	ZONE	DATE	DESCRIPTION OF REVISIONS	BY	APPRD.
NOTE:							
©2014 MECON LIMITED. ALL RIGHTS RESERVED.							
A THIS DRAWING IS THE PROPERTY OF MECON AND IS ISSUED FOR THE SPECIFIC PROJECT MENTIONED THEREIN. THIS IS NOT TO BE COPIED OR USED FOR OTHER PROJECTS UNLESS EXPRESSLY PERMITTED BY MECON.							
	NAME	SIGN. & DATE	SECTION :				
DESIGNED	MADHU	<i>[Signature]</i>	ELECTRICAL				
CAD	RAGHU		SCALE : NTS				
REVIEWED	S.C	<i>[Signature]</i>	SH.No. 1 of 1				
APPROVED	S.C	<i>[Signature]</i>	TYPICAL EARTH CONNECTION FOR STREET LIGHT POLE				
			DRG.No. : MEC/23RT/01/E1/D2/CN/ST/0427				

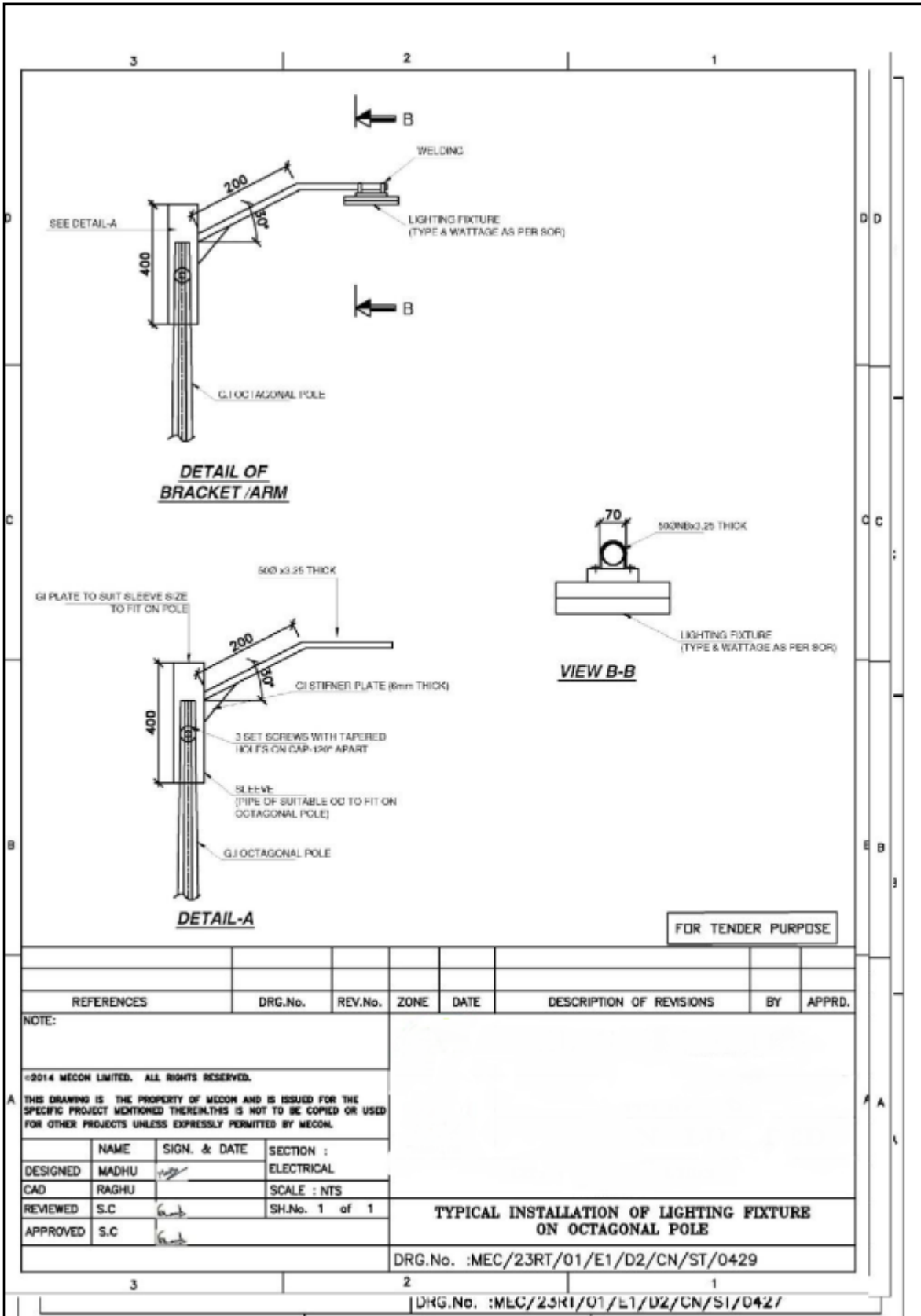

REFERENCES	DRG.No.	REV.No.	ZONE	DATE	DESCRIPTION OF REVISIONS	BY	APPRD.
NOTE:							
©2014 MECON LIMITED. ALL RIGHTS RESERVED.							
THIS DRAWING IS THE PROPERTY OF MECON AND IS ISSUED FOR THE SPECIFIC PROJECT MENTIONED THEREIN. THIS IS NOT TO BE COPIED OR USED FOR OTHER PROJECTS UNLESS EXPRESSLY PERMITTED BY MECON.							
DESIGNED	MADHU	<i>[Signature]</i>	SECTION :		ELECTRICAL		
CAD	RAGHU	<i>[Signature]</i>	SCALE :		NTS		
REVIEWED	S.C	<i>[Signature]</i>	SH.No. 1 of 1		TYPICAL INSTALLATION OF LIGHTING FIXTURE ON OCTAGONAL POLE		
APPROVED	S.C	<i>[Signature]</i>					
DRG.No. : MEC/23RT/01/E1/D2/CN/ST/0429							

DRG.No. : MEC/23R1/01/E1/D2/CN/S1/042/

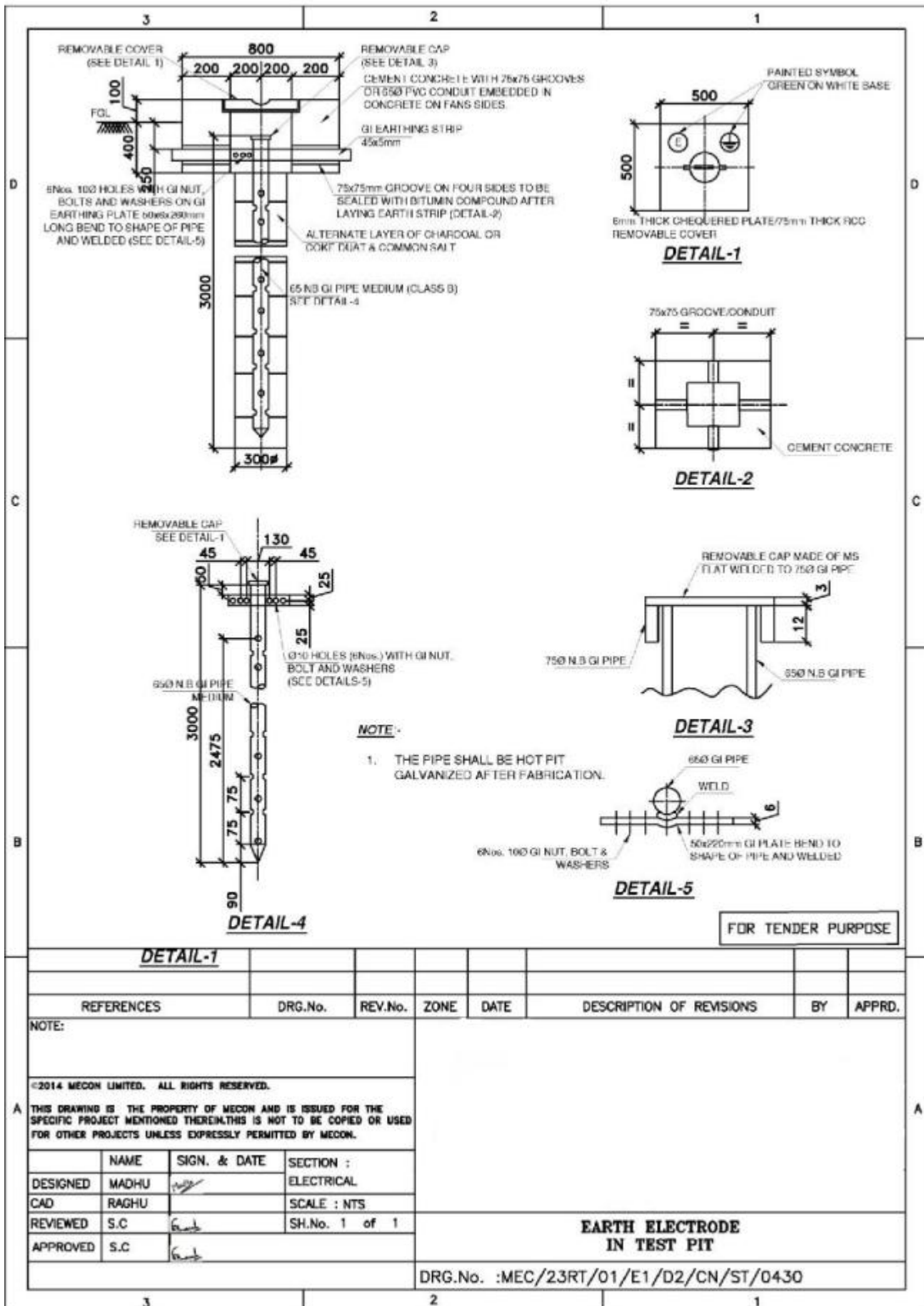

REFERENCES							
DRG.No.	REV.No.	ZONE	DATE	DESCRIPTION OF REVISIONS	BY	APPRD.	
NOTE:							
©2014 MECON LIMITED. ALL RIGHTS RESERVED.							
THIS DRAWING IS THE PROPERTY OF MECON AND IS ISSUED FOR THE SPECIFIC PROJECT MENTIONED THEREIN. THIS IS NOT TO BE COPIED OR USED FOR OTHER PROJECTS UNLESS EXPRESSLY PERMITTED BY MECON.							
DESIGNED	MADHU			SECTION :			
CAD	RAGHU			ELECTRICAL			
REVIEWED	S.C			SCALE :	NTS		
APPROVED	S.C			SH.No.	1 of 1		
				EARTH ELECTRODE IN TEST PIT			
DRG.No. : MEC/23RT/01/E1/D2/CN/ST/0430							

100/10/NO/76/75/02/007/200 100/1000

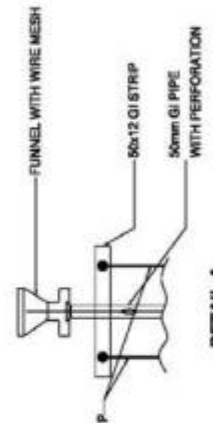
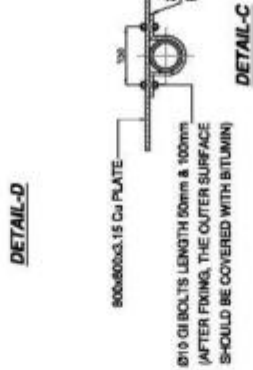
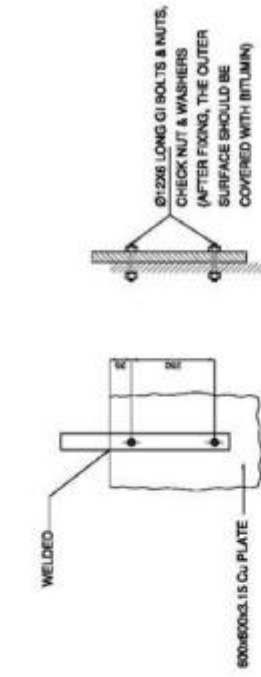
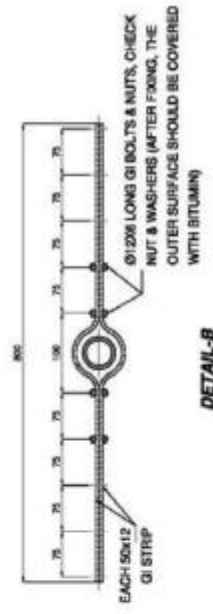
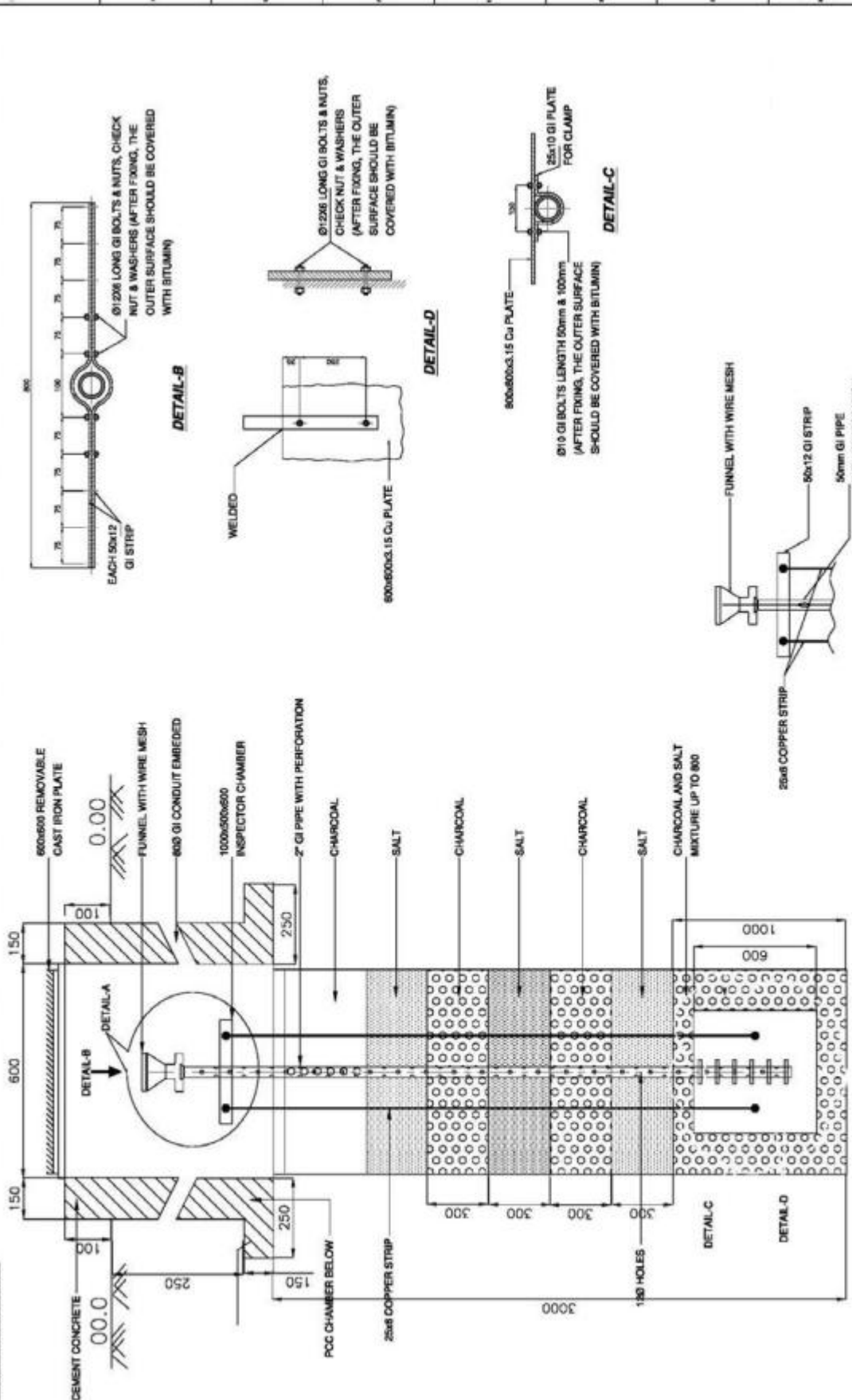

NOTES:-

1. ALL DIMENSIONS ARE IN MM UNLESS OTHERWISE MENTIONED.
2. TO SUIT SOIL CONDITION AT SITE.
3. RESISTANCE OF THE EARTH PIT SHOULD BE LESS THAN 1 OHM.
4. THE ENTIRE EARTH PIT SHALL BE SEALED WITH BITUMIN COMPOUND.
5. THE COMPLETE EARTHING SYSTEM SHALL CONFORM TO IS:2042(1987)

EARTH PIT

NO.	REV.	DESCRIPTION	DATE
1	01	ISSUED FOR THE PROJECT	08.01.17
2	02	REVISED	08.01.17
3	03	REVISED	08.01.17
4	04	REVISED	08.01.17
5	05	REVISED	08.01.17

APPROVED: [Signature] DATE: 08.01.17
 DRAWN: [Signature] DATE: 08.01.17
 CHECKED: [Signature] DATE: 08.01.17
 SCALE: AS SHOWN

PROJECT: TYPICAL ELECTRONIC MARTIN PIT
 SHEET NO: 100/10/NO/76/75/02/007/200
 OF 1

PART-III

TECHNICAL SPECIFICATION FOR MECHANICAL WORKS



TENDER NO: GGPL/KKD/C&P/CW/2523/VS

Contents

- 1. INTRODUCTION.....
- 2. SCOPE OF WORK.
- 3. DETAILED SCOPE OF WORK UNDER THE PRESENT TENDER:
- 4. Completion Time Schedule
- 5. General Instructions to the Contractor.....
- 6. REFERENCE SPECIFICATION, CODES AND STANDARDS.....
- 7. APPROVALS
- 8. STRUCTURES, SERVICES AND OTHER PROPERTY.....
- 9. SAFETY
- 10. PROGRESS OF WORK.....

1. INTRODUCTION

- 1.1. M/s Godavari Gas Private Limited, a joint venture company of APGDC and HPCL is engaged in development of CNG (Compressed Natural Gas) as fuel to commercial & private vehicles through filling stations in the automobile sector & PNG (piped Natural Gas) to Industrial, household, commercial sector through City Gas Distribution Networks (CGDN) at different Geographical Areas in East and West Godavari districts of Andhra Pradesh. PNGRB has awarded to Godavari Gas the work of development of City Gas Distribution Network for East and West Godavari district Geographical Areas (GA's) for distribution of CNG and PNG to various consumer segments. Presently, GGPL is planning to implement CNG & City Gas Distribution Network (CGDN) to supply Natural Gas to domestic, commercial, industrial and automobile consumers distributed over the Geographical Areas (GA's) of East and West Godavari Districts.
- 1.2. GGPL planning to provide compressed natural gas (an eco-friendly fuel) & related services in Automobile, Domestic, Commercial and Industrial sectors in the state of Andhra Pradesh.
- 1.3. GGPL is creating infrastructure & services for Automobile Sector and provide compressed natural gas (an eco-friendly fuel) in the East and West Godavari Dists of Andhra Pradesh state.
- 1.4. **GENERAL INFORMATION:**
This tender deals with various Mechanical works involved in 8 nos. of CNG Mother / Daughter booster stations proposed in BPCL /IOCL /HPCL retail outlets land procured through EOI with car dispensers., 3 nos. of CNG Mother/Online stations proposed on GGPL's land, 6 nos. of De-compression unit installations for City Gas Distribution . All are located in East and West Godavari Geographical areas in the state of Andhra Pradesh. The brief scope of work is presented in Table-I.
Further, the contract will be valid for 2 years from the date of FOA (Fax of Acceptance) and job will be intimated after award of contract for one or more than one. of CNG stations in a phased manner depending upon the availability of Plots/ ROs by the Client within a time period of 24 months from the date of FOA (Fax of acceptance), which shall be considered as the validity of the subject works contract and the contractor will be provided with the site details along with the intimation. The contractor shall have to deploy his manpower within seven days from the time of intimation for execution of work by EIC/Client.

2. SCOPE OF WORK.

The broad scope of work under "Mechanical Works" is essentially but not limited to the following.

TENDER NO: GGPL/KKD/C&P/CW/2523/VS

- i) Supply and Laying of SS (SS316) tubes and SS compression ferrule fittings, valves, mass flow meter, Conductive core thermoplastic hose with break away coupling within trenches/ above ground and pneumatic testing for CNG application.
- ii) Erection of Mechanical equipment. Handling (including lifting and transportation from Client's store within city to respective CNG stations) and erecting in position, either on the foundation or on roof of office building at ~ 3 to 4 m above ground level. Contractor's scope includes supply of all material and accessories including but not limited to any fixtures, clamps, gasket, nut bolts, etc.. Scope also includes supply of all lifting tools / necessary accessories and hiring of cranes for same.
- iii) Supply, erection & commissioning of miscellaneous items as explained in SOR and specification (like Air Compressor for tyre inflating, Gas genset-Fire fighting equipment like DCP, Sand bucket, CO₂ extinguisher etc.)

2.1. The scope of work (activity-wise) at CNG stations in BPCL/IOCL/HPCL retail outlets, CNG stations in land procured through EOI and at Mother station are as given below.

FACILITIES ENVISAGED IN VARIOUS STATIONS : TABLE-I

Part No.	Type of CNG station / decompression unit installation	Supply , Laying& Pneumatic testing of SS 316 tubes for CNG line	Transportation and Erection of cascades	Supply, erection & commissioning of miscellaneous items.
Part-A	Online CNG station in BPCL /IOCL/HPCL Retail outlet (RO)/land procured through EOI with car dispensers.	SS tubing from 1(ONE) no. of CNG Compressor to 1(ONE) no. of CNG Cascade of 4500WL/ 3000 WL and 2(TWO) nos. of Car Dispensers.	1(ONE) no. of 4500 WL/3000 WL CNG storage Cascade for car dispensers.	1(ONE) no. of DCP75 kg, 1(ONE) no. of DCP 9 kg, 1(ONE) no. of CO ₂ - 4.5 kg fire extinguisher and 1 (ONE) no. of Sand Bucket Stand with 4 Nos. Buckets
Part-B	Decompression unit installation	SS tubing from 1(ONE) no. of CNG De-compression unit to CNG storage cascade to LCV unloading point	1(ONE) no. of 4500 WL/3000 WL CNG storage Cascade.	1(ONE) no. of DCP 9 kg, 1(ONE) no. of CO ₂ - 4.5 kg fire extinguisher and 1 (ONE) no. of Sand Bucket Stand with 4 Nos. Buckets.

TENDER NO: GGPL/KKD/C&P/CW/2523/VS

Part-C	Mother / On-line CNG station on land of Godavari Gas Pvt. Ltd. with Car and Bus Dispensers and LCV loading facility.	SS tubing from 2(TWO) nos. of CNG Compressors to 3(THREE) nos. of CNG Cascades, 2(TWO) nos. of Car Dispensers, 1(ONE) no. of Bus dispenser and 1(ONE) LCV loading facility.	2(TWO) nos. of 4500 WL/3000 WL CNG storage Cascade for car dispensers and 1(ONE) no. of 4500 WL/3000WL CNG storage Cascade for bus dispensers	1(ONE) no. of air compressor with tyre inflator, 2(TWO) nos. of DCP75 kg, 7(SEVEN) nos. of DCP 9 kg, 3(THREE) nos. of CO ₂ - 4.5 kg fire extinguisher and 5 (FIVE) nos. of Sand Bucket Stand with 4 Nos. Buckets., 1(ONE) no. of 30 KVA gas genset
--------	--	---	---	---

3. DETAILED SCOPE OF WORK UNDER THE PRESENT TENDER:

Detailed scope of work is divided under different sub-heads. List of sub-heads along with different activities (with brief specification) is evolved and estimated quantities are given. The tenderer has to quote on sub-head wise per unit rate as mentioned.

Generally the following shall constitute the Contractor's scope of work but not limited to as given herein:

3.1. SCOPE OF WORKS FOR SUPPLY, LAYING, TESTING & COMMISSIONING OF SS TUBING

- 3.1.1. Supply of SS 316 tubes with SS ferrule fittings and SS ball valves, mass flow meter, conductive core thermoplastic hose with breakaway coupling (above ground / within trenches) for CNG application.
- 3.1.2. Receiving and upkeeping the materials procured by contractor in a good condition.
- 3.1.3. Laying of SS 316 tubes with SS ferrule fittings and SS ball valves, mass flow meter, conductive core thermoplastic hose with breakaway coupling (above ground / within trenches) for CNG application.
- 3.1.4. SS tubes shall be clamped to the MS Angle (within trench)/ rails on above ground at every 1000mm using of PVC heavy duty clamp of Swagelok/Parker/Dk-Lok/Vaishnavi hydraulics pvt Ltd./Vardhaman bearings/ AK industries make. **U-Clamping with rubber sheet is not acceptable.** It is not permitted to flatten Tubes for clamping purpose.
- 3.1.5. Carrying out pneumatic testing with Nitrogen at 280 bar(g) and purging with Nitrogen as per the provided procedures elsewhere in the document; providing all tools, tackles, instruments, manpower and other related accessories for carrying out the testing of tubes.

TENDER NO: GGPL/KKD/C&P/CW/2523/VS

- 3.1.6. Deputing of person during commissioning of CNG station (Actual gas charging in SS tubing) and checking of gas leakage in SS tube/fitting.
- 3.1.7. Final clean up and restoration of site, facilities etc. as per the requirement of Owner/ Engineer-in charge.
- 3.1.8. Submission of final material appropriation statements for all the materials procured by contractor, returning surplus material to GGPL stores, reconciliation of material / consumables and obtaining 'No Objection Certificate' from GGPL/ .
- 3.1.9. Any other works not specifically listed herein but required for satisfactory Completion / operation Safety/statutory maintenance of the works in all respects within specified schedule at no extra cost to OWNER.
- 3.1.10. Preparation and submission of “As Built Drawings”.

3.2. LOADING, UNLOADING, TRANSPORTATION &ERECTION OF MECHANICAL EQUIPMENT

- 3.2.1. Receiving of material from stores.
- 3.2.2. Loading of material / equipment on a trailer / truck from GGPL stores and Safe transportation to various sites.
- 3.2.3. Unloading, placement and alignment on foundation -either on ground or aboveground (+ 3.5 m) on roof top / top of structural platform (cascades only)/ on top of CNG compressor.
- 3.2.4. Making Transit Insurance of equipment from stores to site.
- 3.2.5. All equipment transported shall be securely boarded and transported without causing any damage to equipment. Any damage caused during loading, transportation& unloading shall be recovered from the contractor.
- 3.2.6. Leak testing of all equipment after erection as per standard practice and instruction of engineering in charge.

3.3. SUPPLY, ERECTION & COMMISSIONING OF MISCELLANEOUS ITEMS

- 3.3.1. **Air compressor (Pump) :** Supply, erection (at location indicated by EIC), testing and commissioning of Air Compressor-cum-Pump with accessories such as dispensing stand, hose, nozzle, valves, connectors etc complete with Automatic Intelligent Tyre Inflating M/C [AITIM] to supply compressed air for all types of vehicles that visit

TENDER NO: GGPL/KKD/C&P/CW/2523/VS

the station for refuelling of CNG or other purposes.

3.3.2. Fire Fighting Equipment: Supply and installation of (at location indicated by EIC) the following fire fighting equipment in various CNG stations.

- i. 4.5 kg capacity CO₂ type fire extinguishers with steel cylinder with discharge valve conforming to IS:2878-2004. Extinguisher shall be painted with red enamel paint and hardware/ bracket required for fixing to wall.
- ii. 9 kg capacity dry chemical powder (DCP) type fire extinguisher (Manufacturing code IS: 13849) with extinguishers cabinet suitable for inverted operation and fabricated from MS sheet internally protected with anticorrosive treatment and hydraulically tested. Extinguishers shall be externally painted with red enamel paint.
- iii. 75 kg capacity trolley mounted dry chemical powder (DCP) type fire extinguisher (Manufacturing code IS: 10658) suitable for inverted operation fabricated from MS sheet internally protected with anticorrosive treatment and hydraulically tested extinguishers externally painted with red enamel.
- iv. Fire buckets, 9 ltrs. capacity, made of galvanised mild steel (as per IS: 2546) including supplying & fixing of MS angle iron stand to accommodate 4 nos. offire buckets and first fill with sand/water all complete as per direction of Engineer In charge. (Note: One set of Fire bucket consists of 4 buckets with stand).

3.3.3. Gas genset:Supply, erection (at location indicated by EIC), testing and commissioning of 30 KVA gas genset with accessories such as regulators, ball valves and pipe

- 3.4. Survey, making arrangement of safety, security, temporary water &electrical connections, traffic detour etc. setting out the piping GAD by laying out the plans at site.
- 3.5. Preparing QAP and taking approval from including Welder's qualification Test, Internal Test Plan, Hydrostatic Test Procedures, SS Tube &Yard Pipe testing & procedures.
- 3.6. Taking all measures to provide safety to traffic, public, workmen operating staff, equipment, and operation/ maintenance activities, underground/ above Ground services and providing FIRE PROTECTION measures during construction and any other activity to make the station functional in all respect.
- 3.7. To carry out all tests at worksite, approved laboratory and place of manufacture/ fabrication; provide all test certificates from manufacturers &supplier and offer inspection at all stages of procurement/ construction.

TENDER NO: GGPL/KKD/C&P/CW/2523/VS

- 3.8. To maintain and observe all statutory requirement with regards to labour laws, taxation laws, local statutory rules and insurance requirements.
- 3.9. To hand over clear site to GGPL/ after removing all debris subsequent to completed works as per scope.
- 3.10. To submit daily, weekly and monthly progress reports and to attend review meetings both at site and at project office and other discussions with GGPL/ /Statutory Authorities.
- 3.11. To transfer all Test Certificates, warranties / guarantees including maintenance / performance guarantees of various fittings / fixtures, equipment / material and indemnify / GGPL of any liabilities of payments / dues to its suppliers, manufacturers, agents etc.
- 3.12. Marking all as-built details on construction/ fabrication drawings/ data sheets issued by GGPL / and submission of as-built details and drawings in six Sets.

4. Completion Time Schedule

- i. For CNG Station Covered Under Part A -06 (FOUR) months from date of intimation for individual CNG station.
 - ii. For Installations Covered Under Part B -06 (FOUR) months from the date of intimation for individual unit.
 - iii. For CNG Station Covered Under Part C -10 (TEN) months from date of intimation for each CNG station
 - iv. In case of issuance for intimation for more than one unit simultaneously for Part-A & Part-B, completion schedule will get extended by additional one month for each additional unit.
- 4.1. The transportation and erection of cascades in each location shall be completed within 7 (seven) working days from the date of intimation by the EIC / Client.
 - 4.2. The supply and erection of Misc. items EXCLUDING Gas Genset in each location shall be completed within 7 (seven) working days from the date of intimation by the EIC / Client.

5. General Instructions to the Contractor

- 5.1. Plan and prepare a schedule for execution and work implementation as per QA/QC plans to be approved by /GGPL. Proper man power set up at site by carrying out a pre-construction survey, establishing the site deviations, requirement of site modifications in construction drawings, earth filling/ cutting requirement etc.

TENDER NO: GGPL/KKD/C&P/CW/2523/VS

- 5.2. Receiving the latest revision of all documents/ drawings from GGPL/ at the commencement of work / during the course of construction and execution of work at site.
- 5.3. In case any discrepancy is found between drawings & documents, the same shall be brought to the notice of the Engineer-in-charge before execution of work and decision of the Engineer-in-charge shall be final and binding to the contractor without any extra cost implication to GGPL.
- 5.4. The contractor has to make all shop drawings wherever necessary, at his owncost, and get it approved by / GGPL before commencement of that work at site.
- 5.5. Specification and descriptions of various items are for identification of material and works to be carried out under them. No cost shall be quoted against these unless mentioned.
- 5.6. Quantities as mentioned are indicative and can have a variation from the quantities actually executed. The contractor is advised to work out the breakup of individual work items and quantities at his own before quoting any rates. GGPL is not liable for any discrepancies in the quantities and no extra time or cost shall be granted on this pretext.
- 5.7. The contractor has to obtain all types of statutory approvals including completion certificate, approval from electrical inspector for electrical work ,electrical Connection, water connection, fire department etc. and all other approvals that might be required to commission the station, from various relevant authorities during the course of work and after completion of works in co-ordination with GGPL/ without any cost implication to GGPL.
- 5.8. The contractor has to arrange all tools and plants, site fencing material, lighting arrangements, store, electricity and water at his own cost.
- 5.9. The contractor should quote keeping this in mind that no request for escalation inthe cost shall be entertained under any circumstances by Owner after placement of order.
- 5.10. The contractor is bound to carry out all on any number of sites simultaneously that may be allotted to him.
- 5.11. The tender contains a set of key tender purpose drawings/ data. These information/ details are for “Tender Purpose only”. The tenderer should visit each location and acquaint himself with site conditions of each site. No deviations and/or claims whatsoever of any kind and nature would be admissible.
- 5.12. The work shall be carried out in city conditions and generally close to the roads and public services conveying a considerable volume of vehicular traffic and human activity. It is deemed necessary that the tenderer considers the “SAFETY” as

TENDER NO: GGPL/KKD/C&P/CW/2523/VS

the MOST IMPORTANT aspect of working conditions and is required to include in his offer all costs (direct and indirect) towards observance, compliance and provision of all safety appurtenances and norms.

- 5.13. Supplying SS tubes, fittings and other free issue items from GGPL's stores and bringing it to site, keeping proper care of, storing the same till they are used for construction and returning the unused material to the store.
- 5.14. Installing site markers, warning signs, fencing etc. and cleaning all unserviceable materials, debris to designated disposal areas and obtain a No Dues Certificate from the concerned authorities.
- 5.15. Handing over the completed works to GGPL for their operation/ use purposes.
- 5.16. The Contractor has to prepare As-Built drawings, shop drawings, fabrication drawings and submit them along with test certificates, guarantee cards/ warranty cards/ service schedule any other purchase documents/ literature for all equipment / fixtures / fittings installed at the time of completion of work.
- 5.17. Any other activity(ies) not mentioned/ covered explicitly above, but otherwise required for satisfactory completion/ operation/ safety/ statutory/ maintenance of the works shall also be covered under the Scope of Work and has to be completed by the Contractor within specified Schedule of Items of Works at no extra cost to GGPL.
- 5.18. The contractor has to return all the drawings issued to him from time-to-time along with the final bill to / GGPL after marking As-built dimensions and details. The contractor is not permitted to make copies of any drawing/ document provided to him.

6. REFERENCE SPECIFICATION, CODES AND STANDARDS

The contractor shall carry out the work in accordance with this Specification, approved construction drawings issued by GGPL, 's Engineering Standards or relevant BIS code as might be required.

Should the Contractor find any discrepancy, ambiguity or conflict in or between any of the Standards and the contract documents, then this should be promptly referred to the Engineer-in-charge (EIC) for his decision, which shall be considered binding on the contractor.

7. APPROVALS

Approval in principle for all work should be obtained from EIC prior to execution. To ensure smooth execution of the work on a day-to-day basis, it will be the Contractors responsibility to liaison with EIC / concerned engineer and obtain necessary approvals.

8. STRUCTURES, SERVICES AND OTHER PROPERTY

8.1. Protection of Structures and Utilities

The Contractor shall at his own cost, support and protect all buildings, walls, fences or other structures and all utilities and property which may, unless so protected, be damaged as a result of the execution of the works. He shall also comply with the requirements in the specification relating to protective measures applicable to particular operations or kind of work

8.2. Interference with Traffic, Street Drainage and General Public

The Work shall be executed in such a manner as to cause a minimum of inconvenience to persons requiring to use public or private roads, lanes, thoroughfares, walkways, rights of use or passages through which the works are to be executed. Closure of roads, etc., shall not be permitted without the approval of the EIC.

The contractor shall conduct his operations at all times, with a view to minimizing as far as practicable noise from construction and other objectionable nuisances (eg. oil leakage, smoke, fumes.)

9. SAFETY

The Contractor shall conform to the requirements outlined in Preamble for safety requirements. In addition, the Contractor shall observe safe working practices in the storage and handling of pipes, SS tubes, flammable fluids, etc. and ensure that smoking or naked flames are not permitted in the vicinity when these works are being executed.

The Contractor shall also protect all work sites with warning signs, barricades and night lighting.

The contractor should ensure that the workers wear safety shoes and helmets while carrying out any work under the present scope.

Where the EIC determines that the Contractor is performing the work in an unsafe manner, he may suspend the work until the Contractor takes corrective action.

Since the work shall be carried out in city conditions and generally close to the highways/roads and public services conveying a considerable volume of vehicular traffic and human activity, it is deemed necessary that the tenderer considers the "SAFETY" as the MOST IMPORTANT aspect of working conditions and is required to include in his offer all costs (direct and indirect) towards observance, compliance and provision of all safety appurtenances and norms.

TENDER NO: GGPL/KKD/C&P/CW/2523/VS

10. PROGRESS OF WORK

The Contractor shall proceed with the Work under the Contract with due expedition and without delay.

The EIC may direct in what order and at what time the various stages or parts of the work under the Contract shall be performed.

If the Contractor can reasonably comply with this direction, the Contractor shall do so. If the Contractor cannot reasonably comply, the Contractor shall notify the EIC in writing giving reasons.

TENDER NO: GGPL/KKD/C&P/CW/2523/VS

PART-III : Mechanical Work

JOB SPECIFICATIONS FOR MECHANICAL WORKS IN CNG STATIONS

CONTENTS

SECTION A	Specifications for Supply of SS Tubes, SS Fittings ,SS Valves& Conductive core thermo plastic hose with breakaway coupling
SECTION B	Specifications for SS Tube Laying and Testing
SECTION C	Specifications for Erection of Mechanical Equipment
SECTION D	Specifications for Supply, Erection & Commissioning of Miscellaneous items

TENDER NO: GGPL/KKD/C&P/CW/2523/VS

MECHANICAL WORKS

SECTION A. Specifications for Supply of SS Tubes, SS Fittings , SS Valves & Conductive core thermo plastic hose with breakaway coupling

CONTENTS

- 1.0 SCOPE OF SUPPLY OF SS TUBES, VALVE & FITTING
- 2.0 TECHNICAL SPECIFICATION FOR SS
TUBES (TS No. PMC/TS/05/62/035)
- 3.0 TECHNICAL SPECIFICATION FOR SS BALL
VALVES (TS No. PMC/TS/05/62/048)
- 4.0 TECHNICAL SPECIFICATION FOR SS FERRULE FIT-
TINGS (TS No. PMC/TS/05/62/047)
- 5.0 TECHNICAL SPECIFICATION FOR THERMO PLASTIC HOSE
WITH BREAKAWAY COUPLING
(TS No. PMC/TS/05/62/049)

TENDER NO: GGPL/KKD/C&P/CW/2523/VS

1. Scope of supply of SS Tubes, SS Valves & SS Fittings

The contractor has to supply SS Tubes, SS Valves & SS Fittings strictly as per technical specification no. PMC/TS/05/62/035, PMC/TS/05/62/047 & PMC/TS/05/62/048 attached.

The SS Tubes, valves and fittings are to be laid, tested and commissioned as detailed in SECTION - B. The balance items are to be re-conciled and submitted to Godavari Gas stores in good condition. The uncountable material beyond the permissible limits as specified in clause no. 6.0 of Section B would not be paid.

The contractor is required to purchase SS Tubes, SS fittings & SS Valves as per the quantities given in Schedule of Rates (SOR) from the approved vendor list enclosed. The contractor shall take prior approval before placement of order and get the QAP approved by / Godavari Gas . The inspection of materials and / or scrutiny of documents would be carried by / Godavari Gas / Third Party Inspection Agency appointed by contractor at his own cost.

TENDER NO: GGPL/KKD/C&P/CW/2523/VS

TECHNICAL SPECIFICATION FOR SS TUBES FOR CNG REFILLING STATIONS

Contents of TS No. PMC/TS/05/25/035

<u>Sl.No.</u>	<u>Description</u>
1.0	SCOPE OF WORK
2.0	CODE & STANDARD
3.0	PRECEDENCE
4.0	DEVIATION
5.0	SAFETY
6.0	SPECIFICATION
7.0	DOCUMENTATION
8.0	PACKING & SHIPMENT
9.0	GUARANTEE

TENDER NO: GGPL/KKD/C&P/CW/2523/VS

1. SCOPE OF WORK

- 1.1. The scope of the tenderer will include manufacture/ supply, inspection/testing/ marking/ packaging/ handling and despatch of SS tubes, as indicated in the Bill of Quantities meeting all the requirements as per ASTM A269.
- 1.2. All codes and standards for manufacture, testing, inspection etc. shall be of latest edition.
- 1.3. Purchaser reserves the right to delete or order additional quantities during execution of order, based on unit rates and other terms & conditions in the original order.

2. CODES & STANDARD

Items	Applicable Codes and Standards
Tubes	ASTM A269, ANSI B31.3

3. PRECEDENCE

In case of any conflict between this job specification and other document, the following order of precedence shall apply :-

- i. Job Specification
- ii. International Standards/ Codes Applicable

4. DEVIATION

Deviations if any required by Tenderer shall be separately furnished against each clause giving reasoning for each deviation. Tenderer to note that except the deviations furnished by them, Tenderer's offer shall be deemed to be in total conformity with the enquiry specifications.

5. SAFETY

- 5.1. All tubes shall be designed as per applicable code & standards.
- 5.2. All part/ component shall meet the requirement for the specified area's Classification.
- 5.3. Area classification shall be Class-I, Division-I ; Group-D as per NEC or Zone-I Group IIA/ IIB as per IS/ IEC Specification or equivalent specifications.

6. SPECIFICATION

TENDER NO: GGPL/KKD/C&P/CW/2523/VS

All the items shall be suitable for compressed natural gas service and meet following specifications.

- 6.1. Tube material shall be stainless steel as per ASTM A269 (Grade TP 316).
- 6.2. Tubing material shall have minimum molybdenum content 2.5%, carbon content of max. 0.030%.
- 6.3. Tube shall be bright annealed.
- 6.4. Tube shall be seamless.
- 6.5. Tube hardness shall be less than Rb 80. Tubes shall be NACE MR 0175 certified for hardness. Hardness test shall be carried out on each tube.
- 6.6. All S.S.tubes shall be online 100% eddy current Tested as per ASTM A1016. In lieu of eddy current Test / non-destructive electric examination, each tube shall be hydrotested as per requirement of ASTM A1016 clause no.26, at a hydrotest pressure of 350 kg/cm²(g). However, it shall be ensured that the test pressure does not result in stresses exceeding the yield strength at test pressure.
- 6.7. Tolerance on outer diameter shall be ± 0.08 mm.
- 6.8. Tube shall be of minimum 5 to 6 meter in length.
- 6.9. Minimum thickness shall be as per following table.

Tube OD	Minimum Wall Thickness	Maximum Allowable Working Pressure psig
1"	0.120"	4700
3/4"	0.095"	4700
1/2"	0.083"	4700
3/8"	0.065"	4800
1/4"	0.035"	4800

Note: Bidder to reconfirm maximum allowable working pressure for each tube size.

- 6.10. Following documents/ certificates to be submitted.
 - i. Chemical composition for heat
 - ii. Chemical composition for products

TENDER NO: GGPL/KKD/C&P/CW/2523/VS

- iii. Tensile test
- iv. Hardness test
- v. Flaring test
- vi. Leak test
- vii. Visual inspection and dimensional check

6.11. Tubing should be clearly marked with the specifications given in the inspection certificate with heat code, lot code, outer diameter and wall thickness with inspection certificate no.,

6.12. Tubes should be supplied with both ends plugged.

7. DOCUMENTATION

Following test certificates shall be furnished along with shipment.

7.1. Test certificate of visual, chemical, Mechanical testing (incl. tensile, hardness, flaring and leak test).

7.2. Manufacturer's standard shop inspection & test report for all items.

7.3. The test report for specified tests.

7.4. Third party inspection report as applicable to meet the requirements of specified codes & standards as applicable.

8. PACKING & SHIPMENT

8.1. All the items shall be suitably wrapped and packaged to withstand rough handling during ocean shipment and inland journey. Tubes should be supplied with both ends plugged.

8.2. The item shall be properly tagged and packaged separately to facilitate easy identification.

8.3. Items shall be wrapped and packaged in such-a-way that they can be preserved in original as new condition.

9. GUARANTEE

9.1. Manufacturer shall guarantee that the design, materials, manufacturing and testing of tubes conform to the requirement of this specification. Manufacturer shall replace all tubes free of costs which fail during field pressure testing or do not perform satisfactorily due to inadequate engineering, substandard material and poor workmanship.

TENDER NO: GGPL/KKD/C&P/CW/2523/VS

- 9.2. The manufacturer shall guarantee against any defect, failure normal functioning occurring during 12 months from the date of commissioning or 24 months from the date of supply whichever is earlier.

TENDER NO: GGPL/KKD/C&P/CW/2523/VS

**TECHNICAL SPECIFICATION FOR SS FERRULE FITTINGS FOR
CNG REFILLING STATIONS**

Contents of TS No. PMC/TS/05/25/047A

<u>Sl.No.</u>	<u>Description</u>
1.0	SCOPE OF WORK
2.0	CODE & STANDARD
3.0	PRECEDENCE
4.0	DEVIATION
5.0	SPECIFICATION
6.0	MARKING, PACKING & SHIPMENT
7.0	DOCUMENTATION
8.0	GUARANTEE

TENDER NO: GGPL/KKD/C&P/CW/2523/VS

1. SCOPE OF WORK

- 1.1. The scope of this specification covers the requirement of design, manufacture/ inspection/ testing at works/ marking/ packaging/ and supply of high pressure SS Ferrule Fittings.

2. CODES & STANDARD

The latest edition of the following standards are referred to in this specification

Items	Applicable Codes and Standards
Bar Stock	ASME SA-479-316 or DIN 4401 or BS:970-316-S31
Forging	ASME SA-182-316 or DIN 4401 or BS:970-316-S31
Thread	NPT ANSI B 1.20.1

3. PRECEDENCE

- 3.1. In case of any conflict between this job specification and other document, the following order of precedence shall apply:
- i. Job Specification.
 - ii. International Standards/ Codes Applicable.

4. DEVIATION

Deviations if any required by Tenderer shall be separately furnished against each clause giving reasoning for each deviation. Tenderer to note that except the deviations furnished by them, Tenderer's offer shall be deemed to be in total conformity with the enquiry specifications.

5. SPECIFICATION

All the items shall be suitable for compressed Natural Gas service and meet following specifications.

5.1. Materials

5.1.1. Fittings shall be manufactured from the following materials :-

- i. Bar stock shall be as per BS:970-316-S31, DIN 4401 or ASME 479-316 but with carbon content less than 0.05% to provide increased resistance to corrosion.
- ii. Forgings shall be as per BS:970-316-S31, DIN 4401 or ASME SA-182-316.

5.1.2. The fittings end connections shall be compatible to tube of hardness \leq Rb80.

TENDER NO: GGPL/KKD/C&P/CW/2523/VS

- 5.1.3. All component parts of the fittings shall be of the same material.
- 5.1.4. The ferrule material shall be able to withstand an atmosphere of Natural Gas, oil and moisture without rusting.

5.2. Design & Manufacture

- 5.2.1. All fittings shall be designed in conformance with the requirements of ASME B 31.3 and applicable standards. Area classification applicable for all items shall be Class-1, Division-1, Group-D as per NEC or Zone-1 Group IIA/ IIB as per IS/ IEC specification or equivalent specification. All fittings shall be designed so that all parts/ components meet the requirements for the specified area classification.
- 5.2.2. The SS fittings shall be of flare less design and four piece construction, consisting of front and rear ferrules, nut and body suitable for use on SS tubes conforming to ASTM A269 TP316.
- 5.2.3. Fittings shall be rated for at least the design pressure as stipulated in the material requisition. The design of fittings shall ensure that they shall be capable of holding full tube burst pressure after only one and a quarter turn pull up of the nut.
- 5.2.4. The threaded ends of fittings shall be NPT as per ANSI B1.20.1.
- 5.2.5. The fittings shall hold the tube with collecting action producing a firm grip on the tube without substantially reducing the tube wall thickness.
- 5.2.6. Fittings shall not torque the tubing during original or subsequent make-up of the connection and should use geometry for inspection before and after makeup. The fittings shall not require disassembly for inspection before or after makeup.
- 5.2.7. All tube fittings shall be guageable for sufficient pull up after one and a quarter turn. All tube fittings shall have a guageable shoulder and there will be no radius at the point where the shoulder meets the neck of the fitting body.
- 5.2.8. The gap inspection gauge shall be easily insertable at finger tight position of nut. The gap inspection gauge shall not be insertable between the nut and shoulder of the fitting after completing only one and a quarter turn pull up of the nut.
- 5.2.9. The tube seat counter bore in the body shall be faced flat 90° to the axis of the tubing to minimize tube expansion and subsequent galling.
- 5.2.10. The sealing and gripping power of the fitting shall be controlled such that the action be-

TENDER NO: GGPL/KKD/C&P/CW/2523/VS

tween ferrules will overcome commercial variations in tubing wall thickness, hardness, diameter and installer skill.

5.2.11. The seal contact areas of the fittings body shall have a machined finish of 32 Ra or better.

5.2.12. The fittings body shall have no machined stop or shoulder to preclude additional tightening in subsequent make-up.

5.2.13. Front Ferrule

- i. The front ferrule shall effect a long, smooth repeatable seal by contact with body and a grip hold on the tube surface.
- ii. The front ferrule shall always remain in a sprung condition to compensate for thermal stresses and to accomplish repeated make and break.

5.2.14. Rear Ferrule

- i) The rear ferrule shall collect the tubing surface, improving the performance of the tubing in systems of high impulse or vibration.
- ii) The rear ferrule shall have a machine recess on the inside diameter and shall have complete surface hardening so as to substantially reduce the required pull up torque. Both the requirements i.e. complete surface hardness and machined recess shall be met for all rear ferrules.

5.2.15. Nuts shall have silver plated threads to act as a lubricating agent to avoid galling and to reduce tightening torque.

5.3. Inspection and Testing

5.3.1. The fitting shall have type approval to either of ASTM F1387/ECER110 test protocols-witnessed by any one of following auditing/inspection agencies.

- i. ASME
- ii. British Standard institute
- iii. Det Norske Veritas (DNV)
- iv. Lloyd's Register
- v. TUV

5.4. Test Reports and Certificates

5.4.1. The manufacturer shall furnish test procedure and typical test reports of all tests conducted on fittings as per the requirements of clause 5.3.

TENDER NO: GGPL/KKD/C&P/CW/2523/VS

6. MARKING, PACKING & SHIPMENT

- 6.1. Heat code traceability number shall be stamped or etched on both body and nut of each fitting.
- 6.2. Replacement nuts and ferrules shall be packaged in a manner so as to allow safe and simple replacement.
- 6.3. All the items shall be suitably wrapped and packaged to withstand rough handling during ocean shipment and inland journey.
- 6.4. Item shall be properly tagged and packaged separately to facilitate easy identification.
- 6.5. Items shall be wrapped and packaged in such-a-way that they can be preserved in original as new condition.

7. DOCUMENTATION

- 7.1. All documents shall be furnished in English language only.
- 7.2. Following test certificates shall be furnished along with shipment.
 - i. Test certificate of chemical, Mechanical testing.
 - ii. Manufacturer's standard shop inspection & test report.
 - iii. The procedure and certificates to be submitted as per the requirements of clause 5.4 of this specification.

8. GUARANTEE

- 8.1. Manufacturer shall guarantee that the design, materials, manufacturing and testing of fittings comply with the requirement of this specification and applicable codes and standards. Manufacturer shall replace all fittings which should result defective or fail during field pressure testing or fail to perform satisfactorily due to inadequate engineering, substandard material and workmanship.
- 8.2. The manufacturer shall guarantee against any defect, failure or malfunctioning occurring during 12 months from the date of commissioning or 24 months from the date of supply whichever is earlier.

TENDER NO: GGPL/KKD/C&P/CW/2523/VS

TECHNICAL SPECIFICATION FOR SS BALL VALVES FOR CNG REFILLING STATIONS

Contents of TS No. PMC/TS/05/25/048

<u>Sl.No.</u>	<u>Description</u>
1.0	SCOPE OF WORK
2.0	CODE & STANDARD
3.0	PRECEDENCE
4.0	DEVIATION
5.0	MATERIALS
6.0	DESIGN & MANUFACTURER
7.0	INSPECTION & TESTING
8.0	OTHER REQUIREMENTS
9.0	TEST REPORTS & CERTIFICATES
10.0	MARKING, PACKING & SHIPMENT
11.0	DOCUMENTATION
12.0	GUARANTEE

1. SCOPE OF WORK

- 1.1. The scope of this specification include design, manufacture/ supply ,inspection/ testing/ marking/ packaging/ handling and despatch of SS Ball Valves as per relevant codes.
- 1.2. Purchaser reserves the right to delete or order additional quantities during execution of order, based on unit rates and other terms & conditions in the original order.

2. CODES & STANDARD

Items Applicable Codes and Standards
Valves MSS-SP-99

3. PRECEDENCE

- 3.1. In case of any conflict between this job specification and other document ,the following order of precedence shall apply :
 - 3.1.1. Job Specification.
 - 3.1.2. International Standards/ Codes Applicable.

4. DEVIATION

Deviations if any required by Vendor shall be separately furnished against each clause giving reasoning for each deviation. Vendor to note that except the deviations furnished by them, Vendor's offer shall be deemed to be in total conformity with the enquiry specifications.

5. MATERIALS

- 5.1. The valve body shall be made out of material conforming to ASTM A479Type 316
- 5.2. Material of construction of ball shall conform to ASTM A276 Type 316.
- 5.3. Material of construction of seat shall be PEEK.

6. DESIGN & MANUFACTURE

- 6.1. All ball valves shall be designed in conformance with the requirements of ASME B31.3, MSS-SP-99 and other applicable code and standards. Area classification applicable for all items shall be Class-1, Division-1, Group-Das per NEC or Zone-1 Group-IIA/ IIB as per IS/ IEC specification or equivalent specification. All fittings shall be designed so that all parts/ components meet the requirements for the specified area classification.
- 6.2. Valves shall be rated for a maximum working pressure of 5000 psig and shall be capa-

TENDER NO: GGPL/KKD/C&P/CW/2523/VS

ble of operation between a temperature range of (-40)° to 250°F.

- 6.3. Valves shall have spring loaded PEEK seats allowing seal-ability over the full pressure range at any port and low operating torque over the full range of pressures and temperatures.
- 6.4. Elastomeric seals, which require no packing adjustment, shall be used.
- 6.5. Valves stem shall be of bottom loaded and blow out proof design.
- 6.6. Ball shall be blow out proof and trunnion mounted when it is specified in SOR.
- 6.7. Valves shall have positive wrench/ handle stops, Phenolic black wrench/handle shall be provided. Wrench/ handle shall indicate the direction to flow. IN the case of three way valves the stem shall also provided a visual indication of flow direction if the handle is removed.

7. INSPECTION AND TESTING

- 7.1. The valve manufacturer shall submit typical type test reports for the following test carrier out on similar valves :-
 - i. Hydrostatic seat leak test shall be carried out with de-ionised water. There shall be no detectable set leakage at 1.1 times the rated pressure of the valve.
 - ii. Gas pressure test for seat and shell shall be carried out with nitrogen at 1000 psig. There shall be no detectable external leakage. Maximum allowable seat leakage shall be 0.1 atm-cc/min.

8. TEST REPORTS & CERTIFICATES

- 8.1. The manufacturer shall supply material compliance certificates.
- 8.2. The valve manufacturer shall provide test procedure and valve inspection and test report for type tests carried out on similar valves as per the requirements of clause 7.

9. MARKING, PACKING & SHIPMENT

- 9.1. Heat code shall be marked on valve body to facilitate tractability.
- 9.2. All the items shall be suitably wrapped and packaged to with stand rough handling during ocean shipment and inland journey.
- 9.3. Each item shall be properly tagged and package separately to facilitate easy identification.
- 9.4. All Items shall be wrapped and packaged in such-a-way that they can be preserved in original as new condition.

TENDER NO: GGPL/KKD/C&P/CW/2523/VS

10. DOCUMENTATION

- 10.1. All document shall be furnished in English language only.
- 10.2. Prior to shipment, manufacturer shall submit following test certificates and documents.
- i. Test certificate of chemical, Mechanical testing.
 - ii. Manufacturers standard shop inspection and test reports.
 - iii. The procedure and certificates to be submitted as per the requirements of clause 8.0 of this specification.
 - iv. Manual for installation, erection, maintenance and operating instructions including a list of recommended spares for valves.

11. GUARANTEE

- 11.1. Manufacturer shall guarantee that the design, materials, manufacturing and testing of fittings comply with the requirement of this specification and applicable codes and standards. Manufacturer shall replace all fittings which should result defective or fail during field pressure testing or fail to perform satisfactorily due to inadequate engineering, sub-standard material and workmanship.
- 11.2. The manufacturer shall guarantee against any defect, failure or malfunctioning occurring during 12 months from the date of commissioning or 24 months from the date of supply whichever is earlier.



TENDER NO: GGPL/KKD/C&P/CW/2523/VS

**TECHNICAL SPECIFICATION FOR CONDUCTIVE CORE THERMOPLASTIC HOSE WITH
BREAKAWAY COUPLING FOR CNG REFILLING STATIONS**

CONTENTS

- 1.0 SCOPE
- 2.0 CODES AND STANDARDS
- 3.0 SPECIFICATIONS
- 4.0 TEST REPORTS & CERTIFICATES
- 5.0 MARKING, PACKING & SHIPMENT
- 6.0 WARRANTY

TENDER NO: GGPL/KKD/C&P/CW/2523/VS

1. SCOPE

- 1.1. The scope of this specification covers the requirements of design, manufacture / inspection / testing at the works / marking / packaging / and supply of flexible fill hose with breakaway coupling for loading and unloading of mobile cascades with all auxiliaries and features required for efficient and safe operation.

2. CODES AND STANDARDS

Unless otherwise specified elsewhere in this specification Flexible fill hose with breakaway coupling and their installation shall conform to the latest revisions of codes and standards listed below.

ITEM	APPLICABLE CODES & STANDARDS
HOSE(For CNG Application)	NFPA-52, AGA1-93, ANSI-4.2112.52
END CONNECTIONS	ASTM A 276, ASTM A479, ASTM A262, Practice-A to E and or EN ISO 3651-2
THREAD	NPT ANSI B 1.20.1

3. SPECIFICATIONS

The specification described herewith are intended to give vendor the technical and operating conditions of the flexible fill hose. Vendor may indicate in his offer, the additional features, which his flexible fill hose has in terms of better design, enhance reliability etc.,.However such feature may be accepted subject to client's review and approval.

Each flexible fill hose should have the following specifications:-

- i) The core material shall be non-metallic, electrically conductive, thermoplastic flexible hose of min.3m length with both ends of ½"OD SS 316 tube in complete conformity with the relevant codes & standards as mentioned above.
- ii) Two or more layers of fibre reinforcement.
- iii) Thick layer of abrasion resistant Polyurethane black cover to prevent abrasion and display better wear resistance shall be provided on the hose.
- iv) Electrical conductivity shall comply with AGA1-93.
- v) End connections shall be SS 316 material confirming to relevant design standards as specified above.
- vi) The whole assembly shall be rated for a working pressure of 5000 psig and shall be rated for temperature range of -40 to 250°F.
- vii) Vendor shall also include supply of Breakaway coupling suitable for NGV industry in each hose.

TENDER NO: GGPL/KKD/C&P/CW/2523/VS

- viii) Specific conductivity of filling hose shall be 0.512 Mega ohms for lengths upto 180” (approx. 4.5 mtr.) and 3.5 Mega ohms for length over 180” and up to 1200”(approx. 30 mtr.)
- ix) Minimum Burst Pressure of Flexible Fill Hose shall be four times the working pressure.

4. TEST REPORTS AND CERTIFICATES

- i) The manufacturer shall supply material compliance certificate.
- ii) The manufacturer must submit product type test reports for the following tests conducted on CNg hoses.
 - a. Hydraulic Burst pressure test.
 - b. Hydraulic proof pressure test.
 - c. Hydraulic leakage test.
 - d. Change in length test.

5. MARKING, PACKING AND SHIPMENT

- i) All hoses shall be duly marked with the manufacturer's name, series, material, hose size and all relevant standards applicable.
- ii) All the items shall be suitably wrapped and packaged to withstand rough handling during ocean shipment and inland journey.
- iii) Each item shall be properly tagged and packaged separately to facilitate easy identification.
- iv) All items shall be wrapped and packaged in such a way that they can be preserved in original as new condition.

6. WARRANTY

- i) Manufacturer shall guarantee that the design, materials, manufacturing and testing of CNG hoses comply with the requirement of this specification and applicable codes and standards. Manufacturer shall replace if resulted defective or fail during field pressure testing or fail to perform satisfactorily due to inadequate engineering, substandard material, and workmanship.
- ii) The manufacturer shall guarantee against any defect, failure or malfunctioning occurring during 12 months from the date of commissioning or 24 months from the date of supply whichever is earlier.

MECHANICAL WORKS

SECTION - B
SS TUBE LAYING AND TESTING

CONTENTS

- 1.0 SCOPE OF WORK AND TECHNICAL SPECIFICATION**
- 2.0 INSTALLATION PROCEDURE**
- 3.0 REMAKE OF FITTINGS**
- 4.0 REFERENCE SPECIFICATION, CODES AND STANDARDS**
- 5.0 SCOPE OF SUPPLY**
- 6.0 SCRAP AND EXCESS MATERIAL**
- 7.0 HIGH PRESSURE GAS LEAK TESTING PROCEDURE**

TENDER NO: GGPL/KKD/C&P/CW/2523/VS

1. SCOPE OF WORK AND TECHNICAL SPECIFICATION

1.1. LAYING OF SS TUBE

Laying, testing and commissioning of SS tubes and fittings complete with all supports. The SS tube fixing clamps from approved vendors shall be procured and installed by the contractor. Payment shall be at the rate for the work set out in the agreed Schedule of Rates.

Contractor shall engage GODAVARI GAS LTD./ approved sub-contractor for this specialised work. The list of parties are enclosed in Annexure-I.

1.2. SCOPE OF WORKS: FOR LAYING, TESTING & COMMISSIONING OF SSTUBING

Generally the following shall constitute the Contractor's scope of work but not limited to as given herein:

- 1.2.1. SS tubes shall be clamped at every 1000 mm by the heavy duty PVC tube clamps of approved make. The practice of flattening tubes for clamping purposes shall not be permitted.
- 1.2.2. Tubes shall be bent using tube benders only and any hot bending will be totally rejected. Tubes shall be cut using pipe cutting device. Hot cutting is not allowed.
- 1.2.3. Carrying out pneumatic testing at 280 bar and purging with nitrogen at 2 bar as per approved procedures; providing all tools, tackles, instruments, manpower and other related Accessories for carrying out the testing of tubes. Leakages, if any, observed during testing shall be rectified without any additional cost to owner.
- 1.2.4. Start-up and commissioning assistance.
- 1.2.5. Handing over the completed works to GODAVARI GAS LTD. for their operation/ use purposes.
- 1.2.6. Final clean up and restoration of site, facilities etc. as per the requirement of owner / Engineer-in charge.
- 1.2.7. Preparation and submission of "As Built Drawings".
- 1.2.8. Co-ordination as required with other agencies/Contractor(s) till the time the commissioning operations are complete.
- 1.2.9. Any other work not specifically mentioned herein, but required for the satisfactory completion/ operation/ safety/ statutory/ maintenance of the works shall also be covered under the scope of work and has to be completed by the Contractor within specified schedule at no extra cost to GODAVARI GAS LTD.

2. INSTALLATION PROCEDURE

2.1. TUBE END PREPARATION

- 2.1.1. Cut the ends square with a hacksaw and a suitable guide tube cutters are satisfactory for most tube materials but tend to work harden stainless steel. As such proper care shall be exercised while cutting the SS tubes to avoid the hardening.
- 2.1.2. Burrs must be removed inside and outside for proper entry into fitting to prevent contamination and/ or restricted flow. 'Swagelok' / 'Parker' debarring tool shall be used.
- 2.1.3. Remove all fittings, chips, and grit before attachment of fittings.

2.2. ASSEMBLY

- 2.2.1. Tube line fabrication must be accurate so that the tube end easily enters the fitting in proper alignment. Do not force an improperly fitted tube line into the fittings
- 2.2.2. Ensure that the tube end is bottomed against the shoulder in the fitting body. This is necessary to prevent movement of the tube while the nut forces the ferrule to grip the tube and to seal through any imperfections that may exist on the outside tube surface.
- 2.2.3. Never permit the fitting body to rotate during tube end make-up, use two wrenches. Assemble port connectors to components first and hold with a wrench while making up the tube joint. All types of union bodies must be held while each of the tube ends is made up.
- 2.2.4. Never attempt to make up by torque.
- 2.2.5. Always turn the nut the prescribed amount regardless of torque required. Fitting end plugs required only 1- ¼ turn from finger tight make up in all sizes.

3. REMAKE OF FITTINGS

A disassembled joint can be remade, simply by retightening the nut to the position of the original make up. For maximum number of remakes, mark the fitting and nut before disassembly. Before retightening, make sure the assembly has been inserted into the fitting until the ferrule(s) seats in the fitting. Retighten the nut by hand. Rotate the nut with a wrench of the original position as indicated by the previous marks lining up. (A noticeable increase in Mechanical resistance will be felt indicating the ferrule is being re-sprung into sealing position.) Then snug the nut 1/12 turn (1/2 hex flat) past the original position.

4. REFERENCE SPECIFICATION, CODES AND STANDARDS

The Contractor shall carry out the work in accordance with this specification, 's Engineering Standards, ASME B 31.8 - Gas Transmission and Distribution Piping Systems, Oil Industry Safety Directorate (OISD) norms.

Should the Contractor find any discrepancy, ambiguity or conflict in or between any of the Standards and the contract documents, then this should be promptly referred to the Engineer-in-Charge (EIC) for his decision, which shall be considered binding on the contractor.

5. SCOPE OF SUPPLY

5.1. SUPPLIED BY THE CONTRACTOR AT HIS OWN COST AS PART OF THIS-SPECIFICATION:

The procurement and supply of SS tube clamps at the appropriate time of all the materials and consumables except for the materials specifically enlisted under Owner's scope of supply, shall be entirely the Contractor's responsibility and its rates of execution shall be inclusive for all these items, as follows but not limited to these:

- i. Heavy duty PVC clamps for tubes, anchor bolts of various sizes for fixing to concrete structure.
- ii. Primer and finishing paints.
- iii. All material for minor civil works like grouting etc.,
- iv. Minor structural steel for fabrication of tube/ tray supports like MS plates, GI plates, flats, pipe etc.,
- v. Nitrogen for Pneumatic testing and for purging.
- vi. All items not expressly mentioned in the Contract but which are necessary for the satisfactory completion and performance of the Work under this Contract.

Note: Samples of all the consumables items / test certificates required to be approved by EIC.

6. SCRAP AND EXCESS MATERIAL

Every month the Contractor shall submit an account for all the materials issued to him by the owner in the standard proforma prescribed for this purpose by the Engineer-in-charge.

On completion of the work, the Contractor shall submit material appropriation statements for all the materials issued by the Owner in the standard proforma. The following scrap allowances are permissible.

ITEM	UNACCOUNTABLE	SCRAP
Tube	1 %	1% (Less than 0.3 m)
Valves	0 %	0%
Ferrule Fittings	0 %	0 %

All excess materials and scrap shall be returned after duly accounting for, to the GODAVARI GAS LTD. stores. Where materials are to be weighed before return, the Contractor shall be responsible for making necessary arrangements for weighing etc.

TENDER NO: GGPL/KKD/C&P/CW/2523/VS

The contractor shall not use scrap sections obtained during the course of construction for fabrication of temporary supports or other items without prior written permission of Engineer-in-Charge.

If the Contractor fails to return the surplus material aforesaid, the Owner will charge the Contractor for such unreturned material at penal rates, which will be deducted from whatever amount is due to the Contractor. In case any material issued by the Owner deteriorates during storage by the Contractor, new material will be issued to him if available at penal rates, but delay in procuring such materials will be at the Contractor's account only. *Any damaged valve and ferrule fittings should not be used and shall be returned to GODAVARI GAS LTD. stores.*

7. HIGH PRESSURE GAS LEAK TESTING PROCEDURE WITH NITROGEN.

- Pressure testing of Gas line to be started after completion of installation.
- All gas piping connections, valves, and appliance connections and valves are inspected visually for tightness and good condition.
- A gas pressure gauge is connected in the line. The calibration certificate of the gauge shall be submitted to / Godavari Gas Pvt. Ltd. for review before start of the testing.
- The gas service valve is opened to permit gas to flow into the gas piping distribution system, and then the valve is closed again, securely.
- The gas pressure gauge should read gradual increase in pressure.
- The tube shall be pressurised to 60 bar gradually and hold for 30 minutes. Leak testing shall be carried out with soap solution at all joints of Valves, Regulators & Fittings.
- If any leak is found, tube shall be depressurised and leak arrest shall be done. **Leak arrest by using Teflon tape is not acceptable.** Ensure Leak arrest is done at 60bar at all the joints.
- The tube shall be pressurised to 100 bar gradually and hold for 30 minutes. Leak testing shall be carried out with soap solution at all joints of Valves, Regulators & Fittings.
- If any leak is found, tube shall be depressurised and leak arrest shall be done. **Leak arrest by using Teflon tape is not acceptable.** Ensure Leak arrest is done at 100bar at all the joints.
- The tube shall be pressurised to 200 bar gradually and hold for 30 minutes. Leak testing shall be carried out with soap solution at all joints of Valves, Regulators & Fittings.
- If any leak is found, tube shall be depressurised and leak arrest shall be done. **Leak arrest by using Teflon tape is not acceptable.** Ensure Leak arrest is done at 200bar at all the joints.
- The tube shall be pressurised to 280 bar gradually and hold for 240 minutes.

TENDER NO: GGPL/KKD/C&P/CW/2523/VS

Leak testing shall be carried out with soap solution at all joints of Valves, Regulators & Fittings. Pressure reading shall be noted down every 30 minutes.

- If any leak is found, tube shall be depressurised and leak arrest shall be done. **Leak arrest by using Teflon tape is not acceptable.** Tube shall be pressurised again and Ensure Leak arrest is done at 280bar at all the joints.
- Final leak testing at 280 bar shall be witnessed by /Godavari Gas Pvt. Ltd..

TENDER NO: GGPL/KKD/C&P/CW/2523/VS

SECTION - C

ERECTION OF MECHANICAL EQUIPMENT

CONTENTS:

- 1. SCOPE OF WORK FOR LOADING, UNLOADING, TRANSPORTATION & ERECTION OF EQUIPMENT.**
- 2. EQUIPMENT WEIGHTS & SIZES.**

SECTION-C

LOADING, UNLOADING, TRANSPORTATION & ERECTION OF MECHANICAL EQUIPMENT

1. SCOPE OF WORK:

1.1. Generally the following shall constitute the Contractor's scope of work but not limited to as given herein:

- i. Receiving of material from stores.
- ii. Loading of material/ equipment on a trailer / truck from stores. Safe transportation to various sites.
- iii. Unloading, placement and alignment on foundation -on ground or on above compressor at +3.5m or above ground at +3.5 m at roof top of office building (cascade only).
- iv. Transit Insurance of equipment from stores to site.
- v. All equipment transported shall be securely boarded and transported without causing any damage to equipment. Any damage caused during loading, transportation & unloading shall be recoverable from the contractor.
- vi. All the equipment shall be leak tested after erection as per instruction of engineering in charge and standard practice.

2. Equipment weight & sizes

Sl. No.	Equipment	Size	Weight / Unit Appx.
1.	Cascade 4500 L (water capacity)	5.5 m X 2.0m X 2.0m (H) Approx.	9.0 T
2	Cascade 3000 L (water capacity)	4.0m X 2.0m X 2.0m (H) Approx.	6.0 T

All excess, unutilized or defective materials and scrap shall be returned after duly accounting for, to the GODAVARI GAS LTD. stores. Where materials are to be weighed before return, the Contractor shall be responsible for making necessary arrangements for weighing etc.

The contractor shall not use scrapped or defective materials obtained during the course of construction for fabrication of temporary supports or other items without prior written permission of Engineer-in-Charge.

TENDER NO: GGPL/KKD/C&P/CW/2523/VS

If the Contractor fails to return the surplus material aforesaid, the Owner will charge the Contractor for such un-returned material at penal rates, which will be deducted from whatever amount is due to the Contractor. In case any material issued by the Owner deteriorates during storage by the Contractor, new material will be issued to him if available at penal rates, but delay in procuring such materials will be at the Contractor's account only.

Contractor to arrange all equipment & tools such as cranes, winch, lifting hook etc and skilled & semiskilled manpower and consumables for erection of all the Mechanical equipment.

SECTION - D

SUPPLY, ERECTION & COMMISSIONING OF MISCELLANEOUS ITEMS

CONTENTS:

1. AIR COMPRESSOR-CUM-PUMP
2. FIRE FIGHTING EQUIPMENT
3. 30 KVA SOUND-PROOF ACOUSTIC GAS GEN SET

SUPPLY, ERECTION & COMMISSIONING OF MISCELLANEOUS ITEMS

1. **Air compressor (Pump)with Automatic Intelligent Tyre Inflating M/C (AITIM):**
Contractor will supply, erect at prepared location, test and commission an Air Compressor-cum-Pump with Accessories such as dispensing stand, hose, nozzle, valves, connectors etc complete with Automatic Intelligent Tyre Inflating M/C [AITIM].

Air compressor - cum- pump shall supply compressed air for all types of vehicles that visit the station for refuelling of CNG or other purposes.

Details of air compressor along with inflator:

Type Drive	- V belt drive
Electrical Supply	- 415V/3ph/50Hz
Discharge pressure	- 12 kg/cm ²
Motor	- As per manufacturer
Make	- Ingersoll Rand/Elgi/KPCL/CP
Display	- Digital in both system [MKS & CGS]
Alarm	- Digital & Sound
Control	- To stop filling of air on alarm/set point.
Housing	- Steel/ Fibre glass- coated/painted in approved colours with GODAVARI GAS LTD. Logo.
Dispensing Hose	- Non -conductive.
AITIM	- Precision Testing Machines Pvt Ltd, NewDelhi/Instrument Research Association Pvt. Ltd,Bangalore/or any other approved make.

Note- One-year spares shall be supplied along with those for accessories.

2. Fire Fighting Equipment:

Contractor will supply and erect at designated locations the fire fighting equipment.

The details of the fire fighting equipment are given below.

- i. Supply and installation of 4.5 kg capacity CO₂ type fire extinguishers with steel cylinder with discharge valve and conforming to IS: 2878-1975. Extinguisher shall be painted with red enamel paint and hardware/ bracket required for fixing to wall.
- ii. Supply and installation of 9 kg capacity dry chemical powder (DCP) type fire extinguisher with extinguishers cabinet suitable for inverted operation and fabricated from MS sheet internally protected with anticorrosive treatment and hydraulically tested. Extinguishers shall be externally painted with red enamel paint. Manufacturing code IS: 13849.
- iii. Supply and installation of 75 kg capacity trolley mounted dry chemical powder (DCP) type fire extinguisher suitable for inverted operation fabricated from MS sheet internally protected with anticorrosive treatment and hydraulically tested extinguishers externally painted with red enamel. Manufacturing code IS: 10658.
- iv. Providing & installation of galvanised mild steel fire buckets of 9 ltrs. capacity, made as per IS: 2546 including supplying & fixing of MS angle iron stand to accommodate 4 nos. of fire buckets and first fill with sand/water all complete as per direction of Engineer In charge (One set consisting of 4 buckets with stand).

Note: The equipment are to be purchased from the vendor list enclosed.

3. SPECIFICATION FOR GAS GENERATOR SET (30KVA)

1. SCOPE

This specification covers the design, engineering, shop testing, supply, erection, testing and commissioning of 415V, 3 phase, 30 KVA gas generator set for CNG station along with all required accessories including integral AVM pads, AMF Panel and weather and sound proof acoustic enclosure.

The rating applies for supplying continuous power at variable load for unlimited annual hours. A 10% over load is allowed for up to 1 hour in every 12 hours.

2. CODES AND STANDARDS

The Gas generator set with all its components shall comply with Environmental (Protection) 3rd Amendment Rules 2016 and all other latest applicable standards, regulations and safety codes in the locality where the equipment shall be installed. The equipment shall comply with following British standards, Indian standards or equivalent British or International Standards with latest revisions.

- o ISO 3046/1
- o BS 5514
- o AS 2789
- o DIN 6271
- o ISO 8528/1
- o ISO 8528-5

3. GENERAL

- 3.1. The Gas Generator set shall be outdoor type complete with suitable acoustic enclosure, to limit noise level to 75 db at 1 metre from the enclosure surface. Gensets should be provided with integral acoustic enclosure at the manufacturing stage itself. The set shall consist of Gas Engine coupled to suitable alternator having self, brush less/ static excitation system with PMG and include all necessary accessories and control panel as specified and as required.
- 3.2. The engine and generator shall be mounted on an integral robust fabricated steel frame with anti vibration mounting pads. No separate foundation will be provided. Required set of foundation bolts, nuts and washer etc. And set of spanner and tools shall be supplied by the bidder.
- 3.3. The gas genset should meet CSA,UL, NFPA or other comparable safety standards.
- 3.4. The generator set shall be factory built and production tested.
- 3.5. The generator set shall be capable of taking the block loading in single step.
- 3.6. The generator shall have integral vibration isolation.
- 3.7. The generator shall have advanced Digital Controller for the engine and alternator combine with LED display unit for display of system parameters and fault indication of both the engine/ alternator.
- 3.8. The generator set shall have cooling system rated for 50°C ambient temperature.

TENDER NO: GGPL/KKD/C&P/CW/2523/VS

- 3.9. The generator shall have a test certificate confirming the generator load parameters.
- 3.10. The generator shall have auto start feature with programmed cranking cycles.
- 3.11. The generator shall have package mounted line circuit breaker for protection.
- 3.12. All the electrical/instrumentation fittings / equipment, junction box shall be flame proof and shall bear valid certification.
- 3.13. The generator set shall have a spark arrestor and a catalytic converter fitted on it.
- 3.14. Lifting lugs must be provided for safe handling and the gas generator shall be mounted on the iron base frame which shall be grouted on the concrete foundation.
- 3.15. The material used for station piping shall be carbon steel for connection between GO-DAVARI GAS 's tap-off point and gas genset inlet / metering device.

4. GAS ENGINE

- 4.1. The generator set shall be powered by proven field tested 4 stroke, min. 4 cylinder, water cooled gas engine suitable for operating on natural gas with a power output of at least 5% more than the maximum power required by the alternator along with all standard engine components and shall have following features:
 - a. Internal Exhaust system with approved spark arrestor and catalytic converter.
 - b. The gas engine shall be suitable for block loading in one step and supplied with electronic isochronous governor for optimum fuel, spark performance and frequency regulation of $\pm 1\%$.
 - c. Residential grade silencer.
 - d. 70A / 12V battery Charging Alternator.
 - e. 12V starter motor.
 - f. High engine temperature safety & shutdown.
 - g. Low lube oil pressure safety & shutdown.
 - h. Dry type air filter.
 - i. Cartridge type lubrication oil filter.
 - j. The generator set engine should be fitted with 3-way catalytic converter capable of reducing NOx, CO and HC by over 70%.
 - k. The catalyst supplier should have its product validated by ARAI.
 - l. The generator set shall have a gas train to operate at an inlet gas pressure of 14 to 49 kg/cm²(g). Any facility required for reduction in the pressure from the gas inlet pressure for the operation of gas generator shall be to the bidder scope.
 - m. The generator set shall be able to operate on the following gas configuration;

Component	Average Gas Composition (Mol%)
Methane (mol%)	94

TENDER NO: GGPL/KKD/C&P/CW/2523/VS

Ethane (mol%)	4.2
Propane (mol%)	1.3
i-Butane (mol%)	0.2
n-Butane (mol%)	0.2
i-Pentane (mol%)	0.02
n-Pentane (mol%)	0.02
Nitrogen (mol%)	0.06

NOTES:

- O2 not more than 0.5% mole. Total non hydrocarbon not more than 2.0%
- Total S including H2S not more than 10 ppm by weight
- H2S not more than 4 ppm by volume.
- Moisture content in the range 112 to 114 kg/MMSCM

5. LUBE OIL SYSTEM

Automatic pressure lubrication system shall be provided. Bidder shall also indicate the specific lube oil consumption and capacity of the lube oil tank.

6. ENGINE STARTING SYSTEM

Starting of gas engine shall be by electrical starting system. Electrical starting system shall comprise of a starter motor, batteries, battery charger and all the necessary instruments and accessories. Batteries and battery charger shall be supplied by the bidder.

7. AIR INTAKE AND EXHAUST SYSTEM

Air intake filter and silencer shall be provided. The exhaust system shall consist of an exhaust gas driven turbo charger, exhaust gas silencer, necessary piping, adapters, accessories etc.

8. GOVERNING SYSTEM

The gas engine should have electronic isochronous governing. Governor shall be provided for keeping constant speed within permissible limits with variable load. The governor shall be electronic type..it shall be capable of operating on isochronus mode i.e. the speed of the engine (frequency of the generator set) shall remain constant irrespective of the load on the gas generator set upto 100% capacity. RPM indicator and tachometer to trip the gas generator set during over speed shall also be provided.

9. DIGITAL CONTROLLER

The digital controller shall be integrally mounted on generator set and shall have auto-

TENDER NO: GGPL/KKD/C&P/CW/2523/VS

matic start function with provision for manual start / stop / reset and auto options as per technical specs / features listed below:

- a. The digital controller shall have self diagnostics and test function.
- b. Digital controller shall have LED to display Engine parameters like running hours, crank cycle status, Diagnostics.
- c. LED shall also display communication faults like
 - i. High engine Temperature.
 - ii. Low oil Pressure.
 - iii. Fail to start (Over crank safety)
 - iv. Over speed
 - v. Over frequency
 - vi. Over voltage
 - vii. Under frequency
 - viii. Under voltage
 - ix. High battery voltage
 - x. Low battery voltage
 - xi. Auxiliary fault.
- d. Digital Controller shall preferably have a MMI membrane keypad for configuration and adjustment of features like
 - i. Password protection for Menu access
 - ii. System configurations like system voltage, Phase and
 - iii. Frequency settings etc.

10. ALTERNATOR (Power output @ 0.8 power factor)

The alternator shall be designed for the specified rating voltage etc. and shall be single bearing with class 'H' insulation with 13 deg. temp. rise as per NEMA MG1-1.66, IEEE & ANSI standards.

The alternator shall be suitable for continuous operation at 415V, 3 phase, 4 wire system, 50 Hz, 0.8 pf(lag).

The Alternator should be able to take the 100% load in single step.

The alternator shall have following features:

- Brush type, screen protected, revolving field, self excited, self regulated through an AVR /AVR.
- It should have PMG (Permanent Magnet) excitation incorporated for block and motor loads.
- Sustained short circuit current of upto 150% of the rated current upto 5 seconds.
- It should have vacuum impregnated windings with fungus resistant varnish for use in humid areas.
- It should have self ventilated and drip proof construction.
- It should have Superior voltage wave form from a two-thirds pitch stator and skewed rotor.
- + / - 1% voltage regulation (max.)
- IP:23 enclosure
- Two nos. body earthing terminals which shall be separate from the neutral terminal.

TENDER NO: GGPL/KKD/C&P/CW/2523/VS

- Permissible overload 10% for one hour in 12 hours of duration.

11. AMF Panel with Mains By pass

Control Panel shall be suitable for 415V, 3 Phase, 4 Wire, 50Hz, 0.8PF, fabricated out of 2.0mm CRCA MS Sheets, free standing, floor mounting (inside- side acoustic), front hinged, indoor use, cubicle type, bottom gland plates for Cable connections, dust & vermin proof with Powder Coated painting complete with internal wiring, ferrules, inscription plates etc. The push button, lamps will be finalized during detail engineering .

Fuse less design shall be considered.

12. PERFORMANCE REQUIREMENTS

The unit shall be capable of starting from cold condition.

The unit shall be capable of a peak output of 10% in excess of the rated output for a period of one hour out of a total 12 consecutive hours of operation, without exceeding permissible temperature limits and with a fairly clear visible exhaust.

The unit shall operate upto 110% of the rated speed over the entire range of output without undue vibration and noise.

Slam shut off valve or an alternate arrangement should be provided to shut off the supply of gas in case gas pressure exceeds the specified limits.

Proper filter shall be provided before gas regulating unit to ensure protection against any foreign material.

2 nos. ball valve shall be provided for isolating the gas supply from gas genset as and when required.

Any item not mentioned and required for proper functioning of the gas genset / gas train shall be provided free of cost by bidder.

The bidder would be required to submit test certificate of all the equipments in gas gensets / gas train.

The filter should be hydro tested up to 1.5 times of the line pressure at its installation point.

The bidder would be required to submit calibration certificates of pressure gauges and other installed instruments as applicable and submit the detailed P&ID & GAD.

Bidders shall submit the TPI report for inspection of all items of gas gensets and the gas gensets as a whole equipment under operating conditions.

13. WIRING

All control wiring inside the controller shall be carried out with 2.5 sq.mm 1100/650 V grade PVC insulated copper wires.

14. CONTROL SYSTEM

The gas generator set will be normally at rest when the station A.C. supply is available from normal power source. In case of main AC power supply failure, the Gas Generator shall be stated as follows.

On failure of normal station A.C. power supply, Gas Generator set shall start automatically.

When gas Generator set is running & grid power restores, the load shall be transferred to grid automatically and the Gas Generator set will stop after a preset time.

Three attempt starting facility shall be provided for the Gas generator set. In case, the gas engine fails to start and reach rated speed within 30 seconds, it shall be disconnected and locked out automatically.

15. BASE FRAME

Skid mounted type base frame, fabricated from suitable size MS channel, of heavy side members and cross members, providing common bed for engine and alternator, directly coupled together. The base frame shall have provision for grouting the set on grouting bolts as well as fixing on Anti-Vibration Mounts. Provision shall also be made in the base frame for lifting the set.

16. AVM PADS

Vibration Mounting Pads, as recommended by the set manufacturer shall be supplied with the GC set.

17. ACOUSTIC ENCLOSURE

The generator set comprising of engine coupled with alternator for each set should be placed inside an acoustic enclosure having the following salient features :

- i. The enclosure shall be of modular construction with provision to assemble and dismantle easily at site. There should also be adequate provision for taking out the equipment for maintenance / repairing jobs and reinstalling the same after necessary corrective action.
- ii. The engine generator shall be factory enclosed in not less than a 12 guage cold rolled steel enclosure constructed with corner posts, uprights and headers. The roof shall aid in the runoff of water and include a drip edge. The weatherproof and corrosion resistant acoustic enclosure should be duly surface treated, phosphate and finally powder coated for long lasting finish. The sheet metal components should preferably be hot dip, seven tank pre-treated before powder coating with

TENDER NO: GGPL/KKD/C&P/CW/2523/VS

special pure polyester based powder.

- iii. The sound proofing of the enclosure should be done with self extinguishing high quality rock wool / mineral wool confirming to IS 8183. The rock wool should be further covered with fibre glass tissue and perforated sheet. The silencer must be such that sound level is 75 dbAat 1 meter from the enclosure surface.
- iv. Exhaust silencer shall be provided of the size as recommended by the manufacturer and shall attenuate the sound to the level noted above. It shall be supplied with a flexible, seamless, stainless steel exhaust connection as well as with all internal pipe work. A rain cap will be supplied to terminate the exhaust pipe. These components must be properly sized to assure operation with minimum back pressure and high sound when installed. The canopy should be finished in synthetic enamel paint incorporating rust inhibitors and aluminium sprayed silencers and spark arrestors to guarantee a superior and long lasting finish.
- v. The temperature inside the enclosure should be suitable for human comfort. The temperature of exhaust line should not exceed the self ignition temperature of the fuel gas. A high temperature trip system (to shut down the engine by cutting off fuel supply to the engine through the solenoid valve) with variable setting connected to a thermostatically controlled blower must be provided for eliminating excessive heat dissipated by the engine within the acoustic enclosure. Suitable continuous on line temperature monitoring and control system with alarm and shut down mechanism should be provided.
- vi. There should be a provision of emergency shutdown of the generating set (Prime mover) from outside the enclosure.
- vii. The enclosure should be complete with power and control wiring between control panel and alternator and other components like blowers etc. with proper size copper cable. The cables should be terminated using gland and tinned copper sweating sockets and run through guard pipe.
- viii. The enclosure should have sufficient space in and around the generating set to facilitate maintenance and operation of the set.
- ix. The control panel for the Generating set should be installed separately on the same skid in a different enclosure (which need not be acoustic). The connection from the alternator and control panel should be carried out with 3.5 core 120 sq.mm PVC insulated, PVC sheathed armoured copper cable and cable should be terminated with proper size of tinned copper sweating socket and cable glands at alternator and panel end.
- x. All the terminal boxes / junction boxes etc, the battery and self starter connection terminals and its components should be housed inside DGMS approved intrinsically safe enclosure.

TENDER NO: GGPL/KKD/C&P/CW/2523/VS

18. PACKING AND DESPATCH

The unit shall be packed suitably to facilitate installation and transportation. During transport, care shall be taken to avoid damage to paint or accessories of the equipment if any damage is caused during transport, the vendor shall repair the same , free of cost.

19. TOOL KIT

Special tool kit, if any, for the Gas generator set shall be supplied.

20. TESTS & INSPECTIONS

Following tests shall be carried out in GAS Generator:

Routine tests for engine like fuel consumption test at 100% & 50% load for 12 hrs each, 24 hrs running test at 75% load , etc. as per relevant Indian / International standards / manufacturer's standards.

Routine tests for alternator, as per latest IS-4722 or other applicable Indian standards like insulation resistance and high voltage test etc.

8 hour run test with the set completely assembled at works / site with full load and 10% overload. All parameters will be recorded in presence of the customer's representative.

Bidder shall submit copies of routine and type test certificates for approval in required sets before dispatch.

Following inspections shall be carried out in gas generator:

Bidder shall arrange for below mentioned inspection at factory

- a. Visual
- b. Dimensional
- c. Fitment & alignment
- d. Guaranteed parameters.
- e. Painting thickness
- f. Vibration
- g. Sound level

Bidder shall submit the following documents before dispatch:

- a. Outline dimensional drawings with general arrangement
- b. Piping flow sheets and piping layout.
- c. Electrical wiring and schematic diagram along with cable schedule and general arrangement drawing for control panel.
- d. Foundation drawings.
- e. Fuel oil system with instrumentation and control with write-up.
- f. Lube oil system with instrumentation and control with write-up
- g. Governor system and voltage regulator write-up.
- h. Gas Gen set instrumentation and control system with write-up.

21. CERTIFICATION

- 21.1. Bidder shall be responsible for obtaining all statutory approvals, as applicable for all electrical, instruments and control systems.
- 21.2. Bidder shall supply type test certificate in compliance to Environmental (Protection) 3rd Amendment Rules 2016
- 21.3. In general, the following verification shall be provided by the bidder.
 - a. For all flame proof equipments manufactured within India, the testing shall be carried out by any of the approved testing houses –central Mining Research institute (CMRI) / ERTL etc.,
 - b. For all intrinsically safe equipment manufactured within India, the testing shall be carried out by any of the approved testing houses –central Mining Research institute (CMRI) / ERTL etc.,

ANNEXURE - I

LIST OF SUPPLIERS OF MAJOR BOUGHT-OUT ITEMS

Sl.No.	Item Description	Preferred make
1.	Fire fighting equipment	a. Nitin Fire Protection Pvt. Ltd., Mumbai b. Safex Fire Services, Bombay c. Cross fire (India), Gurgaon d. Zenith fire services, Bombay e. Steelage industries Ltd., Chennai. f. Atlas Firetech Pvt. Ltd, Delhi
2.	List of parties for laying SS tubing	a. M/s TechsolEngg Services (I) Pvt Ltd , 210, CB-202A, Guru Harkishan Plaza, Ring Road, Narayana, New Delhi 110028 b. M/s Equipment fabricators , Kannamangala post, Whitefield-Hoskote road, Bangalore-560067 - http://www.ef-india.com / (Contact :Mr.Ravi, Mobile no.9845125348/ Mr.Porus Shroff (Director), Mobile no.9845031272). c. M/s CCD Technical solutions Private limited , No.10, PKM road, Athipet, Chennai-600058 - http://www.ccdtechnical.com / (Contact :Mr.Gurumoorthy, Mobile no.950007659/ N.G.Kumar, Mobile no.9840999270). d. Nichepro Technologies & Consultancy ,# 3, 6th Cross, Gupta Layout, Halasuru, Bangalore - 60008, karthik@nichepro.in, Karthik :- +91 9900087357 e. Shree Manjunatha Engineering Works ,#301, 1st floor, 1st Cross, Vidya Nagar, OPP: SKF Bearings, Bommasandra, Director :- Mr.Veerabhadrapa, veerabhadrapa.v@gmail.com , vennu@smesolutions.co.in , smesvennu@gmail.com , +91-9845590232, +91- 8884600170. f. Sri Lakshmi Engineering Contractors , No. 116, J.B. Link Road IVth Phase, Bommasandra Industrial Area, srilakshmiengcon@gmail.com , Proprietor :- Mr. Sasi.D, Mob:- +919036009595. Note: If a bidder wishes to do the job by themselves or any other sub-contractor, they need to get prior approval from GGPL / after submitting credentials for the same

TENDER NO: GGPL/KKD/C&P/CW/2523/VS

3.	SS fittings & Valves	<p>a. M/s Parker Hannifin India Pvt. Ltd.,Plot EL-26, MIDC, TTC, Industrial Area, Mahape, Navi Mumbai - 400 701 ,Tel. No. : 022- 5907081/82 Fax No. : 022-55901080 ,E-mail : parker@vsnl.com / aoke@parker.com <u>Thru representative</u> M/s Super Technical (India) Pvt. Ltd., 501, Samarpan Complex, New Link Road, Chakala, Andheri (E), Mumbai -400099 Ph: 022 - 2832 3760 / 61, Fax: 2832 3759 ,Email Id :sales@supertechnical.in</p> <p>b. M/s Swagelok, <u>Thru Bangalore Representative:</u> M/s Bangalore Fluid System components Pvt. Ltd., #1,Doddanakkundi Industrial area, Mahadevapura- Post, Bangalore – 560048 Tel No.080-42669100 Mobile: 91 9686700138 Email: bangalore@swagelok.com</p> <p>c. M/s SSP. U.S.A <u>Thru Indian representative</u> M/s Oiltech Consultancy Services, 11, VeenaBeena, Guru Nanak road, Bandra (W), Mumbai - 400 050 (India) Tel.No.:022-56936500,56964146(D) ,Fax No. : 022- 26514429/26405644 E-mail : ashisn@oiltechconsultancy.com ; oil- tech@vsnl.com</p>
----	----------------------	---

		<p>d. M/s Dk-lokCorp.,South Korea only for SS fittings <u>Thru Indian representative</u> METCO MARKETING (INDIA) PVT LTD 104,Niraj Industrial Estate, Off Mahakali Caves Road, Andhe-ri(East), Mumbai-400093, INDIA Tel : +91 22 4073 8484 Fax : +91 22 66938485 E-mail : dipen@metcoindia.com Homepage : www.metcoindia.com</p> <p>Techsol Engineers No. 94, 4th Floor, 2nd Cross, MLA Layout, R.T. Nagar, Bangalore, Karnataka 560032 Tel : +91 8861200084 87 Fax : +91 80 23535285 E-mail : contact@techsolengineers.com</p> <p>e. M/s Hylok, South Korea only for SS fittings <u>Thru Indian representative</u> M/s SSSP Technologies (Hy-Lok) 130 Sahid Dinesh Gupta Road,(29,Sahid Dinesh Gupta Road), Behala ,Jadu Colony, Kolkata -700 034,India, m- 91 98306 88788 e-mailid:- spban1958@gmail.com, phalgunibanerjee943@yahoo.in</p>
4.	SS Tube	<p>a. M/s Sandvik Steel Asia Pvt. Ltd. Steel Division, Mumbai-Pune Road, Dapodi, Pune- 4110212,India Tel. No. : 020-27104562, 27104568 Fax No.: 020-27145022, 27145339 E-mail : genny.dcruze@sandvik.com ; siddarth.mittal@sandvik.com.</p> <p>b. M/s Tubacex India, 402-A, Platina-G block ,Bandra-Kurla complex, Bandra (E),</p>

TENDER NO: GGPL/KKD/C&P/CW/2523/VS

		<p>Mumbai-400 051, Ph No.022-40015 300, 022-40015 350</p> <p>Email: sales@tubacexindia.com</p> <p>c. Ratnamani metals & tubes ltd.</p> <p>Address : 17, Rajmugat Society, Narapur Cross Roads, Ahmedabad - 380013 Gujarat (India).</p> <p>Telephone : +91-79-2741 5501/2/3/4</p> <p>Fax : +91-79-27480999</p> <p>E-mail : info@ratnamani.com</p>
5.	SS Tube clamps	Swagelok/ Parker/ Dk-Lok/ Vaishnavi hydraulics Pvt. Ltd./ Vardhaman bearings / AK industries
6.	Air compressors	KPCL/Elgi/Ingersoll Rand/ Chicago Pneumatic
7.	Automatic Intelligent tyre inflator (AI-TIM)	Precision testing machines Pvt. Ltd./ Instrument Research Association Pvt. Ltd
8.	CNG high pressure hose	Swagelok/ Parker/Eaton Synflex / OPW
9.	Gas generator	Shiva Gen Set(Green Power) / Kohler generators/M/s Enerzea power solutions Pvt.Ltd./ Cyra Engines Pvt. Ltd./Perfect gas generators/Prakash diesels Pvt.ltd/Cooper Corporation



TENDER NO: GGPL/KKD/C&P/CW/2523/VS

CNG DAUGHTER BOOSTER STATION AT RETAIL OUTLETS

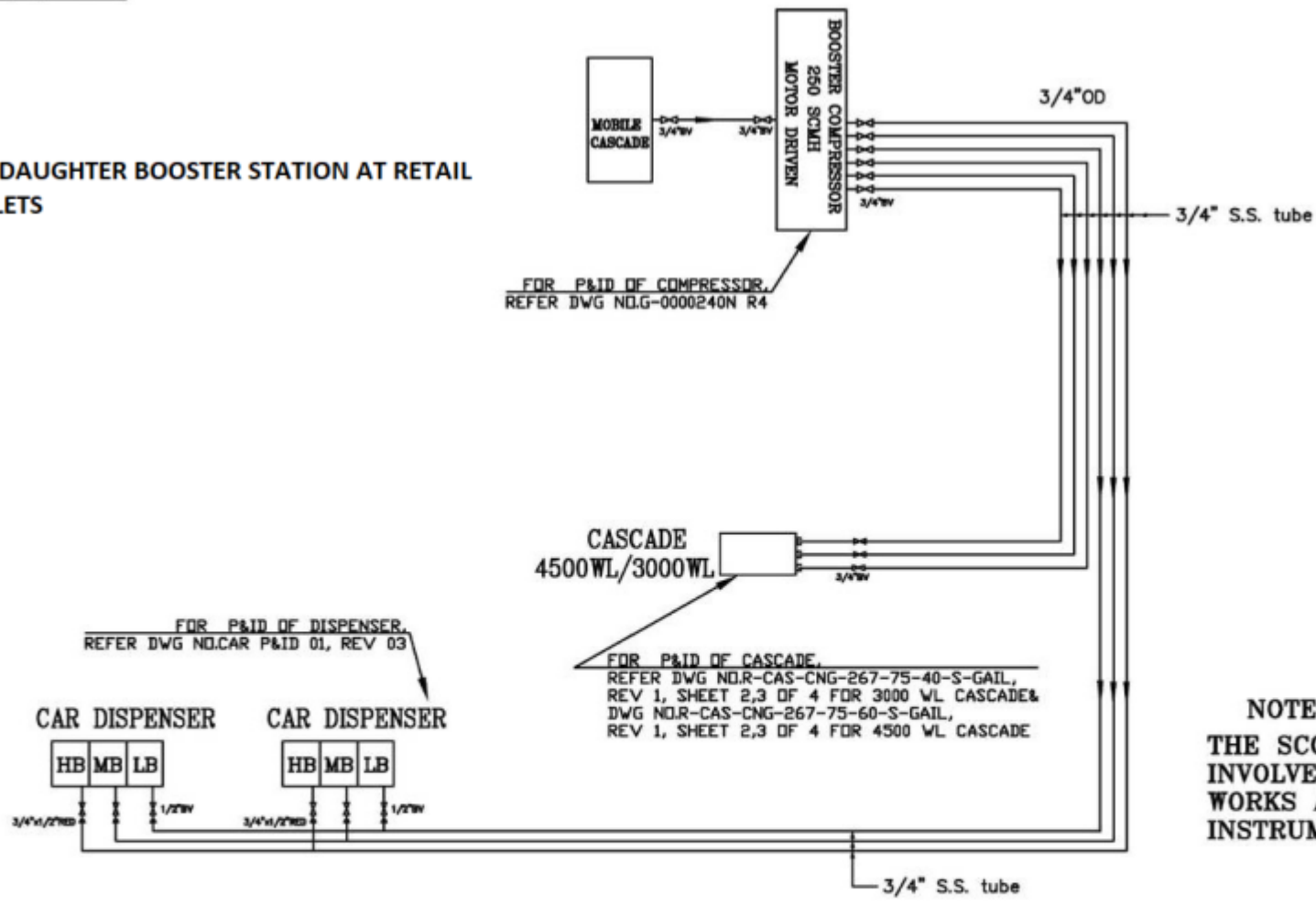

FOR P&ID OF COMPRESSOR REFER DWG NO.G-0000240N R4

FOR P&ID OF DISPENSER REFER DWG NO.CAR P&ID 01, REV 03

FOR P&ID OF CASCADE REFER DWG NO.R-CAS-CNG-267-75-40-S-GAIL, REV 1, SHEET 2,3 OF 4 FOR 3000 WL CASCADE & DWG NO.R-CAS-CNG-267-75-60-S-GAIL, REV 1, SHEET 2,3 OF 4 FOR 4500 WL CASCADE

NOTES:
THE SCOPE OF WORK INVOLVES MECHANICAL WORKS AND INSTRUMENTATION WORKS

SCHMATIC LAYOUT OF SS 316 TUBES WITHIN TRENCHES FOR CNG SUPPLY

CONCLUDED BY:		DESIGNED: M & C		DRAWN: ANN		CHECKED & VERIFIED: ME		APPROVED: R.K.HERA		DATE: 09/05/2018	
REVISIONS:		NO. OF SHEETS: 1		SHEET NO: 1		PROJECT: CNG DAUGHTER BOOSTER STATION AT RETAIL OUTLETS		SCALE: NTS		SHEET 1 OF 1	
DRAWN BY: ANN		DATE: 09/05/2018		DESCRIPTION: CNG DAUGHTER BOOSTER STATION AT RETAIL OUTLETS		BY: ANN		DATE: 09/05/2018		DWG. NO: GGPL/KKD/C&P/CW/2523/VS	

TENDER NO: GGPL/KKD/C&P/CW/2523/VS

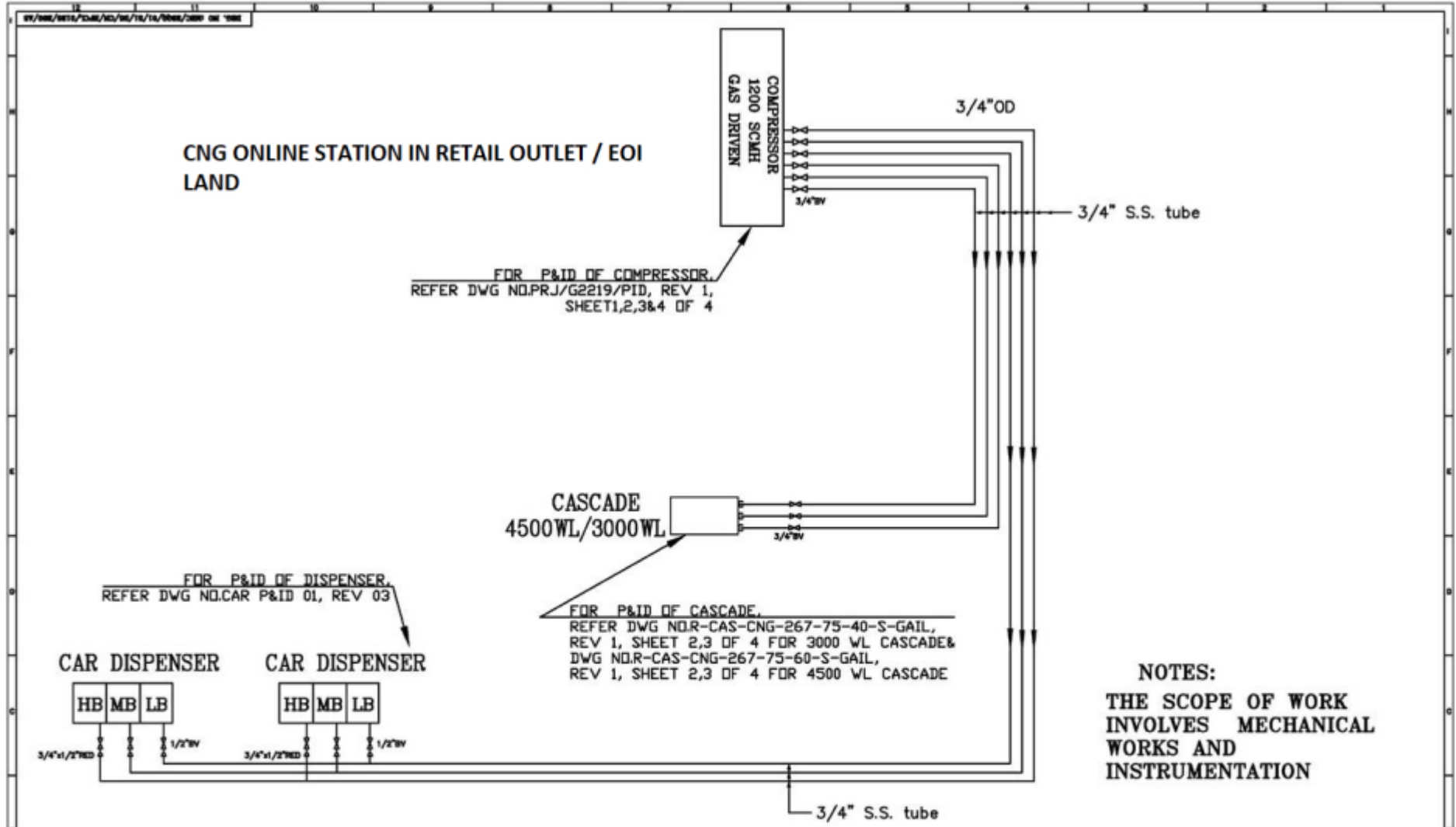

SCHEMATIC LAYOUT OF SS 316 TUBES WITHIN TRENCHES FOR CNG SUPPLY

CONCURRED BY:		REVISION		REVISION	M & C
					ANN
					ANN
					CNG ONLINE STATION AT RETAIL OUTLETS
					P&ID OF CNG ONLINE STATION IN RETAIL OUTLET
					SCALE : NTS
					SHEET 1 OF 1
					DATE 31/05/2018
					DWG. NO. GGPL/2523/21/21/24/C&P/CW/2523/VS/AS

TENDER NO: GGPL/KKD/C&P/CW/2523/VS



PART-IV

TECHNICAL SPECIFICATION FOR INSTRUMENT WORKS

TENDER NO: GGPL/KKD/C&P/CW/2523/VS

SPECIFICATION FOR 3KVA UPS

1.0 SCOPE

The intent of this specification is to define the requirements of uninterrupted power supply system and the associated battery bank sets. Tenderer's scope of work includes design, manufacture, testing, packing and delivery to site and installation, testing & commissioning of the complete UPS system with battery banks etc. as per this specification & data sheet.

2.0 STANDARDS

2.1 In general the equipment covered by this specification shall, unless otherwise specified, be in line with the requirement of any of the latest applicable standards of

- a) Bureau of Indian Standards
- b) British Standard Institution
- c) American Standard Institution
- d) International Electro Technical Commission
- e) IEEE

2.2 Wherever the requirements in this specification are in conflict with any of the above Standards, the requirements under this specification shall be binding.

3.0 GENERAL REQUIREMENTS

3.1 Basic Particulars for Design

- a) Suitable for commercial application.
- b) Single-phase voltage and frequency controlled output.
- c) Suitable protection shall be provided in the control circuit to guard against instability of phase controlled rectifier due to electrical oscillation, which may be present in input supply as caused by emergency Gas Genset.
- d) The load shall normally be fed from the inverter.
- e) Battery shall be suitable to maintain the power supply in the event of mains failure or battery charger failure for the time periods specified
- f) Static by pass switch to connect the load to the mains supply through static voltage stabilizer or hot standby UPS, as per the configuration, without interruption to the load in the event of inverter failure.

3.2 Rectifier/ Battery Charger

- 1. Transient and surge protection circuit in input circuit to protect UPS from surges and voltage spikes.
- 2. Automatic boost and float charging control
- 3. Charger shall simultaneously supply entire power necessary for inverter and to keep the battery of required capacity in fully charged condition. Provision for

automatic charging in both float and boost shall be made.

3.3 Constructional Features

1. Free standing, floor mounted indoor type and complete with all interconnection
2. Dust and vermin proof
3. Units shall be self contained and serviceable
4. Suitable for non air conditioned room.

3.4 Battery unit

Ampere-hour capacity of the battery shall be selected on the following basis:

- a) Load power factor of 0.8
- b) Aging factor of 0.8
- c) Battery state of charge factor of 0.88
- d) Temperature correction factor shall be taken as specified in data sheet
- e) Minimum end cell voltage shall be 1.1V per cell for Ni-Cd battery & 1.85 V per cell for SMF LA/VRLA battery.
- g)

$$\text{Battery Current} = \frac{\text{Inverter Efficiency} \times \text{End cell voltage} \times \text{No of cells}}{\text{Inverter rated KVA} \times \text{Rated load p.f}}$$

- i) Battery stands in multi row/ single tier formation. Stand Material shall be as per battery manufacturer's standard.

4.0 DRAWINGS AND DOCUMENTS

4.1 The following documents shall be submitted along with the offer:

- a) List of two years operation and maintenance spare.
- b) Technical data sheet and check list duly filled.
- c) Space requirement for UPS & auxiliary panels and battery bank

4.2 The following drawings shall be submitted for approval on award of contract.

- a) G.A. of panel, battery stand,
- b) Bill of Material.
- c) Schematic & Wiring diagram for reference.
- d) Charger sizing calculation.

4.3 Final drawings, operation & maintenance manual and erection Instructions shall be submitted along with dispatch of equipments in three sets in hard copy & two sets in soft copy (CD/DVD).

5.0 INSPECTION

- 5.1** The contractor shall submit Quality Assurance Plan (QAP) for respective equipments within 3 weeks of award of contract. QAP shall be prepared and furnished by the contractor in Form No. 11.20(4.4) F-10 along with their internal in process quality checks.
- 5.2** Batteries shall be tested for type and 'Acceptance Test'/ Routine Test at battery manufacturer's works and test reports shall be submitted for review and approval.
- 5.3** Final acceptance testing along with the batteries shall be done at site. Site acceptance test procedure shall be submitted by the Contractor along with QAP.

6.0 PACKING AND DESPATCH

The equipment shall be properly packed for transportation by ship / rail or trailer. The equipment shall be wrapped in polythene sheets before being placed in crates / cases to prevent damage. Crates / cases shall have skid bottoms for handling. Special notations such as "Fragile", "This side up" "Centre of gravity", "Weight", "Owner's particulars", 'PO nos.'" etc, shall be clearly marked on the package together with other details as per purchase order. Contractor shall supply above packed material at required place as specified elsewhere.

DATASHEET FOR 3 KVA UPS

UNINTERRUPTED POWER SUPPLY		
1.0 INPUT POWER SUPPLY		
1.1	Voltage/ Phase / Frequency	230 V AC (+)10% & (-)15% 1Ph., 50 Hz \pm 6%
1.2	System fault level	50 kA for 1 Sec
2.0 SITE CONDITION		
2.1	Design Maximum	50°C
2.2	Max. Relative humidity	95% RH (max. humidity and temperature do not occur at same time)
3.0 OUT PUT REQUIREMENT		
3.1	Voltage / Phase / Frequency	230V \pm 1% AC, Single phase, 50 Hz \pm 0.1%
3.2	Output waveform	Pure Sinusoidal Wave
		Voltage distortion (THD): Less than 3% for linear loads& Less than 5% for non linear loads.
3.3	Transfer time between AC and Battery modes	0 ms (bumpless)

TENDER NO: GGPL/KKD/C&P/CW/2523/VS

4.0 SYSTEM REQUIREMENTS		
4.1	Rating (KVA at 0.8 pf.)	As per SOR
4.2	Type of inverter	The inverter circuit should be IGBT based, fully microprocessor controlled with latest proven technology
4.3	Overload capacity	125% of the rated output for 10 minutes & 150% for 1 minute.
4.4	Inverter efficiency	>90% for normal load and not below 85% for 25% of load
4.5	Type of enclosure	Unitized, Floor mounted
4.6	Internal protection	All live parts shrouded
4.7	Earthing	Doubly Earthed (Two distinct terminals to be made available)
4.8	Crest Factor	$\geq 3:1$
4.9	Input Power Factor	0.8 to 0.85
4.10	Load Power Factor	0.8 (with variation between 0.7 to 1.0)
4.11	Overall efficiency	>80%
4.12	Connectivity	Serial port RS232/ 485.
5.0 Battery Bank		
5.1	Type of Battery	As per SOR
6.0 Distribution boxes		
6.1	Distribution Board Details	<u>(1) ACDB 230 V, Single Phase (1 No.)</u> : Incomer : DP MCB Outgoing : 4nos, 6A and 2 nos. 10A MCBs

TENDER NO: GGPL/KKD/C&P/CW/2523/VS



SPECIFICATION FOR 2x 5 kVA HOT REDUNDANT UPS

1.0 SCOPE

The intent of this specification is to define the requirements of uninterrupted power supply system and the associated battery bank sets. Tenderer's scope of work includes design, manufacture, testing, packing and delivery to site and installation, testing & commissioning of the complete UPS system with distribution boards and battery banks etc. as per this specification & data sheet.

2.0 STANDARDS

2.1 In general the equipment covered by this specification shall, unless otherwise specified, be in line with the requirement of any of the latest applicable standards of

- a) Bureau of Indian Standards
- b) British Standard Institution
- c) American Standard Institution
- d) International Electro Technical Commission
- e) IEEE
- f) NEMA

2.2 Wherever the requirements in this specification are in conflict with any of the above Standards, the requirements under this specification shall be binding.

3.0 GENERAL REQUIREMENTS

3.1 Basic Particulars for Design

- a) Suitable for industrial application.
- b) Automatic selection of available phase (out of three phases) in case of outage of power supply of the phase in use for feeding incoming power supply to the UPS.
- c) Single-phase voltage and frequency controlled output.
- d) Suitable protection shall be provided in the control circuit to guard against instability of phase controlled rectifier due to electrical oscillation, which may be present in input supply as caused by emergency Gas Genset.
- e) Parallel hot redundant system with automatic static bypass, common DC battery and solid-state voltage stabilizer as per data sheet and drawing.
- f) The load shall normally be fed from the inverter.
- g) Battery shall be suitable to maintain the power supply in the event of mains failure or battery charger failure for the time period specified
- h) Static by pass switch to connect the load to the mains supply through static voltage stabilizer or hot standby UPS, as per the configuration, without interruption to the load in the event of inverter failure.
- i) AC Distribution board as per data sheet.
- j) Noise level at a distance of 1 m. from UPS panels shall not exceed 65dB.

3.2 Rectifier/ Battery Charger

1. Switched ON through a MCCB.
2. With transient and surge protection circuit in input circuit to protect UPS from surges and voltage spikes.
3. Automatic boost and float charging control
4. Protective features:
 - Maximum current limiting
 - Over temp. trip.
 - Boost charging and float charging current limiting with back up protection against overcharging.
5. Charger shall simultaneously supply entire power necessary for inverter and to keep the battery of required capacity in fully charged condition. Provision for automatic charging in both float and boost shall be made.

3.3 Inverter

1. DC/DC converter for voltage control
2. Control electronics
3. Series reactor and parallel filter
4. Output transformer
5. Protection against the following:
 - Abnormal output voltage
 - Over load trip
 - Low battery voltage
6. Meters
 - For output voltage
 - For output frequency
 - Ammeter
 - Battery current and voltage with indication of status - "in charge" or "discharge".
7. Static by-pass switch
 - Static switch automatically switches the load to the reserve power supply or the mains whenever there is failure in inverter supply to the load.
 - Retransfer of load from stabilized bypass supply to the inverter in auto as well as in manual mode.
 - High-speed fuses shall be provided for protecting the thyristors against accidental overload.

3.4 Constructional Features

1. Free standing, floor mounted indoor type and complete with all interconnection with lifting hooks
2. Dust and vermin proof
3. Sheet steel clad mounted on 100 mm base frame
 - Minimum 2 mm thick for panels
 - Minimum 1.6 mm thick for doors and side covers
4. Units shall be self contained and serviceable
5. The arrangement and layout shall facilitate easy and convenient supervision of the unit while running as well as quick detection of disturbances and trouble-shooting.
6. Copper earth bus bar shall run throughout the length of Panels. All doors & non- current carrying parts shall be suitably earthed.
7. The maximum and minimum operating height of the switches shall be 1800mm and 300mm respectively.
8. Enclosure conforming to minimum IP-31 class.
9. Units shall be provided with cooling fans and louvers.
10. Suitable for non air conditioned room.
11. Interior and exterior colour shall be RAL 7035.

3.5 Battery unit

3.5.1 Ampere-hour capacity of the battery shall be selected on the following basis:

- a) Load power factor of 0.8
- b) Aging factor of 0.8
- c) Battery state of charge factor of 0.88
- d) Temperature correction factor shall be taken as specified in data sheet
- e) Backup time 30 minutes at full load
- f) Minimum end cell voltage shall be 1.1V per cell for Ni-Cd battery & 1.85 V per cell for SMF LA/VRLA battery.

g)

$$\text{Battery Current} = \frac{\text{Inverter Efficiency} \times \text{End cell voltage} \times \text{No of cells}}{\text{Inverter rated KVA} \times \text{Rated load p.f}}$$

- h) Load break switch fuse unit in sheet steel enclosure shall be provided near the battery bank for isolation.
- j) Battery stands in multi row/ single tier formation. Stand Material shall be as per battery manufacturer's standard.

4.0 DRAWINGS AND DOCUMENTS

4.1 The following documents shall be submitted along with the offer:

- a) List of two years operation and maintenance spare.
- b) Technical data sheet and check list duly filled.
- c) Space requirement for UPS & auxiliary panels and battery bank

4.2 The following drawings shall be submitted for approval on award of contract.

- a) G.A. of panel, battery stand, ACDB
- b) Bill of Material.
- c) Schematic & Wiring diagram for reference.
- d) Charger sizing calculation.

4.4 Final drawings, operation & maintenance manual and erection Instructions shall be submitted along with dispatch of equipments in three sets in hard copy & two sets in soft copy (CD/DVD).

5.0 INSPECTION

5.1 Inspection and testing of equipment shall be carried out by the owner/ consultant at the works of the contractor on final product to ensure conformity of the same with the acceptable criteria of technical specification, approved drawings and national/ international standards.

5.2 The contractor shall submit Quality Assurance Plan (QAP) for respective equipments within 3 weeks of award of contract. QAP shall be prepared and furnished by the contractor in Form No. 11.20(4.4) F-10 along with their internal in process quality checks.

5.3 'Type test' including 12 hr. heat run test shall be conducted on one UPS System of each rating and 'Routine test' on the remaining.

5.4 Batteries shall be tested for type and 'Acceptance Test'/ Routine Test at battery manufacturer's works and test reports shall be submitted for review and approval.

5.5 Final acceptance testing along with the batteries shall be done at site. Site acceptance test procedure shall be submitted by the Contractor along with QAP.

6.0 PACKING AND DESPATCH

The equipment shall be properly packed for transportation by ship / rail or trailer. The equipment shall be wrapped in polythene sheets before being placed in crates

TENDER NO: GGPL/KKD/C&P/CW/2523/VS

/ cases to prevent damage. Crates / cases shall have skid bottoms for handling. Special notations such as “Fragile”, “This side up” “Centre of gravity”, “Weight”, “Owner’s particulars”, ‘PO nos.’” etc, shall be clearly marked on the package together with other details as per purchase order. Contractor shall supply above packed material at required place as specified elsewhere.

DATASHEET FOR 2X5 KVA UPS

UNINTERRUPTED POWER SUPPLY		
1.0 INPUT POWER SUPPLY		
1.1	Voltage/ Phase / Frequency	415 V AC (+)10% & (-)15% 3Ph., 50 Hz \pm 6%
1.2	System fault level	50 kA for 1 Sec
2.0 SITE CONDITION		
2.1	Design Maximum	50°C
2.2	Max. Relative humidity	95% RH (max. humidity and temperature do not occur at same time)
3.0 OUT PUT REQUIREMENT		
3.1	Voltage / Phase / Frequency	230V \pm 1% AC, Single phase, 50 Hz \pm 0.1%
3.2	Output waveform	Pure Sinusoidal Wave
		Voltage distortion (THD): Less than 3% for linear loads & Less than 5% for non linear loads.
3.3	Redundancy Switching between both UPS	Bumpless
3.4	Transfer time between AC and Battery modes	0 ms (bumpless)
4.0 SYSTEM REQUIREMENTS		
4.1	Rating (KVA at 0.8 pf.)	As per SOR
4.2	Type of inverter	The inverter circuit should be IGBT based, fully microprocessor controlled with latest proven technology
4.3	Overload capacity	125% of the rated output for 10 minutes & 150% for 1 minute.
4.4	Mode of operation	Parallel Redundant with static bypass & Dual Redundant rectifier
4.5	Inverter efficiency	>90% for normal load and not below 85% for 25% of load
4.6	Type of enclosure	Minimum IP-31
4.7	External Cable Connection	Bottom entry only
4.8	Internal protection	All live parts shrouded
4.9	Earthing	Doubly Earthed (Two distinct terminals to be made available)

TENDER NO: GGPL/KKD/C&P/CW/2523/VS

4.10	Cooling	Forced ventilation with fans
4.11	Noise Level	<65 dB at full Load from 1 mtr distance
4.12	Crest Factor	$\geq 3:1$
4.13	Input Power Factor	0.8 to 0.85
4.14	Load Power Factor	0.8 (with variation between 0.7 to 1.0)
4.15	Overall efficiency	>80%
4.16	Connectivity	Serial port RS232/ 485.
5.0 Rectifier/Charger		
5.1	Automatic phase selection device	Yes
5.2	Input Power factor	>0.8 (minimum) at rated load
5.3	Input current THD (Total Harmonic Distortion) at nominal load	$\leq 25\%$
5.4	Overload Capability	125% minimum for 10 min. 150% minimum for 1 min.
5.5	Inrush current	Limited by soft-start circuit
5.6	Output voltage tolerance	+/- 1%
5.7	DC voltage ripple	<1% with battery connected <2 % Without battery connected
6.0 Bypass		
6.1	Automatic Bypass	Static bypass to provide an un interruptible transfer of load in case of failure of any system component or malfunctioning or overload & the load shall return on the UPS when the malfunctioning or overload is cleared.
6.2	Input connection	Separate for each UPS
6.3	The switching time from inverter to bypass & vice versa	No break type
6.4	Manual/Maintenance Bypass	Shall be provided
6.5	Overload on bypass	150% (minimum) for 1 minutes, 125% (minimum) for 10 min.
7.0 Battery Bank		
7.1	Type of Battery	As per SOR
8.0 Alarms, Indications and LCD Display		

TENDER NO: GGPL/KKD/C&P/CW/2523/VS

8.1	Digital panel Meter with LCD display shall be provided for monitoring	a) Input AC Voltage, current, frequency b) Output AC Voltage, current, frequency. c) Mains ON/OFF, d) Inverter ON/ OFF e) Battery voltage low
8.2	Audible Alarms With LCD Display-	a) Mains Failure b) Battery Low c) UPS fault (Continuous)
9.0 Protective Features		
9.1	Input	Mains Over voltage, under voltage, phase failure
9.2	Inverter	Over voltage, short circuit, overload, over temperature
9.3	Battery	Under voltage at battery terminal, Battery over charge, Battery Over current
9.4	Rectifier & Battery charger	Maximum current limiting Over temp. Trip Boost charging and float charging current limiting with back up protection against over charging.
10.0 Distribution boxes		
10.1	Distribution Board Details	(1) ACDB 230 V, Single Phase (1 No.) : Incomer : DP MCB Outgoing : 4 nos, 6A and 4 nos. 10A MCBs

TENDER NO: GGPL/KKD/C&P/CW/2523/VS

**TECHNICAL SPECIFICATION FOR
MASS FLOW METER**

1. SCOPE

- 1.1. This Specification covers Design, Manufacture, testing, Supply & Transportation, Unloading at project site of Mass flow meter (Model CNG 50 with integral local display) based on Coriolis principle of Micro motion, USA with F-series 2700 transmitter to be used in CNG mother stations of City Gas Distribution project for Bengaluru.

2. GENERAL

- 2.1. Mass flow meter shall be based on Coriolis principle. Installation and manufacturing of Mass Flow meter shall be as per AGA-11. While installing special care shall be taken to isolate the mass flow meter from piping vibration.
- 2.2. Each Mass flow meter shall include a sensor with integral transmitter i.e meter electronics certified intrinsically safe / explosion proof by statutory authority suitable for the required hazardous area as per IS-2148 / IEC-79. Also the offered sensor and the transmitter shall be weather proof to IP65 or better as per IS-2147/IEC-529. Statutory authority for local installation is CCOE.
- 2.3. Offered mass flow meter shall be necessary for Custody Transfer application but not exceeding 0.5% of span.
- 2.4. Calibration for the offered mass flow meter shall be in Kg/hr, cumulative flow. MFM with head mounted integral local display to indicate flow rate (Kg/hr), cumulative gas (in Kgs) etc.; inbuilt totalizer non-volatile & non-resettable type; suitable for hazardous area classification.
- 2.5. Flying lead type electrical termination is not acceptable. All electrical connections shall be ½” NPTF. Cable glands shall be provided for electrical power, signal and control connections. Cable glands shall be double compression type and certified weather proof and explosion proof for the required area classification as per IS-2147 and IS-2148.
- 2.6. Offered mass flow meter shall be completely free from corrosion of measuring tube due to alternating stresses continuously occurring in the tube. Also measuring tube shall be completely free from erosion, which may result due to fluid velocity.
- 2.7. The design of meter electronics shall be in compliance with the electromagnetic compatibility requirements as per IEC-801.
- 2.8. Meter electronics shall include all the associated pre-amplifiers, converters, line riser etc. and shall have enough diagnostic facility to correct live zero, variation, meter factor etc with the help of Laptop. Output of the mass flow meter RS485 type to PLC

TENDER NO: GGPL/KKD/C&P/CW/2523/VS

shall be utilized.

- 2.9. Installation details like straight run requirements, recommendation for horizontal/ vertical installation, minimum distance between upstream and downstream pipe bends from mass flow meter to be provided.
- 2.10. Vendor shall calibrate each Mass flow meter at his shop or any recognized test house with the fluid (Use design process conditions) for which it is to be used as per Clause no.9 of MPMS (Draft standard Nov.2000) or as per ISO 4185 STD. In case it is not possible to calibrate the Mass Flow Meter with actual fluid. Vendor must indicate
- Fluid used for calibration
 - Correction factor / Adjustment required for actual process fluid. In any case, in accuracy when extended to actual process shall not exceed the specified limits (as per manufacturer's standard).
- 2.11. Vendor shall submit the following test certificates and test reports for purchaser's review:-
- Material test certificate with detailed chemical analysis from foundry (MIL certificate)
 - Certificate of radiography / x-ray from any welded joint.
 - Hydrostatic test report with pressure of 1.5 times the design pressure.
 - Calibration report including calibration factors for each mass flow meter
 - Certificate from statutory body for offered sensor and transmitter for required area classification.
- 2.12. **CERTIFICATION:**
The requirement of statutory approvals for usage of equipment / instruments / system in electrically hazardous area shall be as follows:
- The vendor shall be responsible for obtaining all statutory approvals, as applicable for all instruments and control systems.
 - Equipment's / instruments / systems located in electronically hazardous area shall be certified for use by statutory authorities for their use in the area of their installation. In general, the following verification shall be provided by the vendor.
 - Bidder shall provide certificates (from BSEEFA FM, UL, PTB, LCIE etc.) from country of origin for all intrinsically safe / flameproof protected by other methods .Equipment / instrument / systems, which are manufactured outside India, if required, bidder shall provide necessary certification / approvals / authentication, for all such intrinsically safe / flame proof equipment / instrument / systems, by the Indian authority-Chief controller of Explosive (CCOE), Nagpur, India.
 - For all flame proof equipment manufactured within India, the testing

shall be carried out by any of the testing houses- central Mining Research Institute (CMRI) / ERTL etc. The items shall in addition bear the valid certification from CCOE.

3. Specification for MFM:

- 3.1. Specifications of MFM sensor (Coriolis CNG series sensor: 1/2-inch (15mm); 316L stainless steel):
- a) Coriolis CNG series sensor: 1/2-inch (15mm).
 - b) 316L stainless steel.
 - c) Process connections: 3/4-inch NPT female adapter ; or 3/4" OD X 3/4" OD . If MFM comes with 3/4" NPT Female adapter, then 2 nos. of male connectors of 3/4" NPTM X 3/4" OD SS fittings of required pressure rating are to be supplied by the vendor along with MFM.
 - d) Compatible size 12VCO union fittings.
 - e) Case options: Standard case.
 - f) Electronic Interface; For integrally mounted 2700 transmitter
 - g) Approvals: ATEX equipment category 2 (zone 1) / PED compliant.
 - h) Language: English installation manual.
 - i) Factory options: Standard product
- 3.2. Specifications of MFM transmitter (Coriolis Flow & density transmitter):
- a) Coriolis Flow & density transmitter
 - b) Mounting / housing material: Integral mount transmitter.
 - c) Power: 18 to 100V DC and 85 to 265V AC; self switching.
 - d) Display: Backlit dual line display for process variables and totalizer reset.
 - e) Output: One mA; One frequency; RS485.
 - f) Conduit connections: 1/2-inch NPT.
 - g) Approvals: ATEX-Equipment category 2 (Zone 1- Flame proof terminal compartment).
 - h) Language: English installation manual and English configuration manual.
 - i) Software options : Weights & Measures custody transfer and meter verification, hardware locking & software locking arrangement required.
 - j) Standard product.

For applications requiring simultaneous monitoring of multiple flow variables

- a) Selected combinations of outputs including milliamp, frequency, and discrete I/O.

TENDER NO: GGPL/KKD/C&P/CW/2523/VS

- b) Modbus, HART, wireless HART, FOUNDATION field bus and PROFIBUS-PA digital communications.
 - c) Simultaneously outputs multiple variables, including mass flow rate, volume flow rate, Gas standard volume flow rate, density, temperature and drive gain.
 - d) Compact, integral mounting to sensor with 360 degrees of rotation.
 - e) Class I, Division 1/ Zone 1 local operator interface.
 - f) View process variables, handle alarms, control totalizers, meter configuration and more.
 - g) Interface functions shall be customized and password protected.
 - h) Shall support English language.
 - i) 20 Hz / 100 Hz selectable response time.
4. Coriolis true Mass Flow Meter with integral display unit should be provided to ensure accuracy and direct Mass Flow measurement shall confirm to AGA 11 standard. Mass flow meter (Indicating Type) should be designed for custody transfer metering of CNG and meet the following requirements:

Principle of metering – Coriolis Flow rate : 1 to 100 kg/min.

Accuracy : $\pm 0.5\%$ (inclusive of linearity, hysteresis & repeatability error) Repeatability : $\pm 0.3\%$ or better

Zero stability: 0.01 kg/min or better

Pressure rating:

Flow tube rating : Max: 345 bar, Normal: 255 bar. Process fluid temperature : -40 to +125°C. Ambient temperature limits: -20- to +60°C.

Materials of construction: Wetted parts : SS 316L

Sensor housing : 304L stainless steel

Totaliser – Non resettable type

Enclosure – IP65 or better, NEMA 4 & Ex. Proof for transmitter and sensor. Pressure & temp influence – Nil.

Calibration traceability – NIST/NMI/PTB/ISO/IEC 17025

TENDER NO: GGPL/KKD/C&P/CW/2523/VS

Pressure rating of wetted parts – 5200 psi at 25°C as per ANSI B 31.3/ASME

EMI effect on sensor and Transmitter – To the requirement of EMC to latest IEC/EN standard

Vibration effect –As per IEC 68.2.6 / SAMA PMC 31.1 (1980) or latest standard. Approval – ATEX/CSA/FM/CENLEC/SEV

W&M- Statutory authority of country of origin and from ministry of consumer affairs, Govt. of India.

Output – RS 485 / frequency.

Output to be available –RS 485 / frequency / Analog duly programmed.

Each flow meter should be provided with a liquid crystal display (LCD) for ongoing flow monitoring and totaliser.

Mass flow meter shall have diagnostic facility to check live / dynamic zero, configurable parameter, constants etc through laptop.

Provision for sealing /locking of mass flow meter / transmitter shall be provided to avoid possibility of tempering during use of MFM.

CALIBRATION & CERTIFICATION:

Mass Flow Meter shall be calibrated at minimum six points (Flow range 0 to 100 Kg/min) and calibration certificate shall be valid at the time of Supply. If any of the calibration certificates is not in order, the supplier should replace the affected equipment with valid certificate at supplier cost. The calibration certificates should be presented upon at the time of delivery to site.

A documentation and obtaining statutory approval from the country of origin is in vendor's scope. The offered Mass flow meter must be approved and certified for specified flow and accuracy by recognized and/or other statutory authorities (of the Country of Origin).

The meters shall be type approved by Weights and Measures department (Ministry of Consumer affairs, India). Supplier shall furnish certificate of stamping & sealing of individual meters by Local Weights & Measures department, India along with certified calibration curve of individual meters.

5. DATASHEETS

Vendor shall furnish all the filled data sheets for the approval of /GGPL. Vendor shall

TENDER NO: GGPL/KKD/C&P/CW/2523/VS

clearly indicate deviation if any in the respective data sheet.

GENERAL	1.	Tag no.		*
	2.	Service		CNG
	3.	Line size & Schedule		*
HAZ LOC	4	Electrical Area Classification		IEC Zone 2 Gr. IIA/IIB
SENSOR	5.	Type		Coriolis
	6.	Function		Mass flow
	7.	Connection size / rating		¾" tube OD, 5200 psig
	8.	Body material		316 SS
	9.	Sensor housing material leads		SS Hermetically sealed
	10.	Sensor / Wetted parts material		316 SS
	11.	Enclosure		WP to IP 65 of better ingress protection.
	12.	Intrinsic safety		Required
	13.	Range Min. Max.	Kg/h	* *
	14.	Accuracy		±0.5% flow rate
	15.	Conduit connection		½" NPTF
	16.	Jacketing		Required.
	TRANSMITTER	17	Function	
18.		Load driving capability in Ohms		600
19		Output signal/protocol type		*
20		Enclosure		Flameproof + WP (IP 65 or better)
21		Intrinsic safety		Required
22		Power supply		*
	23	Conduit connection		½" NPTF

TENDER NO: GGPL/KKD/C&P/CW/2523/VS

	24	Mounting location		*
	25	Max. Distance Allowable - sensor to transmitter		*
	26	Tx to control room receiver		*
	27	Power consumption in Watts		*
FLUID	28.	Fluid - State		CNG-gas
	29	Flow: Min./Nor./Max.	Kg/h	As per TS
	30	Pressure: Operating: Maximum	Kg/cm ² (g)	As per TS
	31	Temperature: Operating: Maximum	°C	As per TS
	32	Operating relative density		
	33.	Relative molecular mass		
	34.	Operating Viscosity	cP	
	35	Maximum allowable pressure	Kg/cm ² (g)	
OPTIONS	36	Filter / Mesh size		
	37	Mounting brackets		Required
	38	Inter Connecting cables		Required
	39	Cable glands/size		Required
	40	Switch /type		
		Contact rating		
	41.	Accessories for hot tap		
OTHERS	42.	Manufacturer		*
	43.	Model No. Meter		*
	44.	Converter		*

‘*’ Vendor to indicate

TENDER NO: GGPL/KKD/C&P/CW/2523/VS

Vendor list of Bought out items:

UPS System and Inverter	M/s Emerson / M/s DB Power/ M/s APlab / M/s Hi-rel
Batteries (Lead acid)	Amco batteries Ltd./ Exide Industries Ltd./ HBLNIFE power system Pvt. Ltd./ Amara Raja Batteries Ltd.
Batteries (Nick-el Cadmium)	Amco batteries Ltd../ HBLNIFE power system Pvt. Ltd
Mass flow meter	Micro motion (CNG 50with 2700 transmitter)

TENDER NO: GGPL/KKD/C&P/CW/2523/VS



PART-V

**TYPICAL CNG STATIONS AND
DE-COMPRESSION UNIT LAYOUT DRAWINGS**

LIST OF LAYOUT DRAWINGS

SI NO.	DESCRIPTION
1.	Typical layout of CNG online station
2.	Typical layout of CNG Daughter booster station
3.	Typical layout of CNG mother station
4.	Typical layout of CNG De-compression station

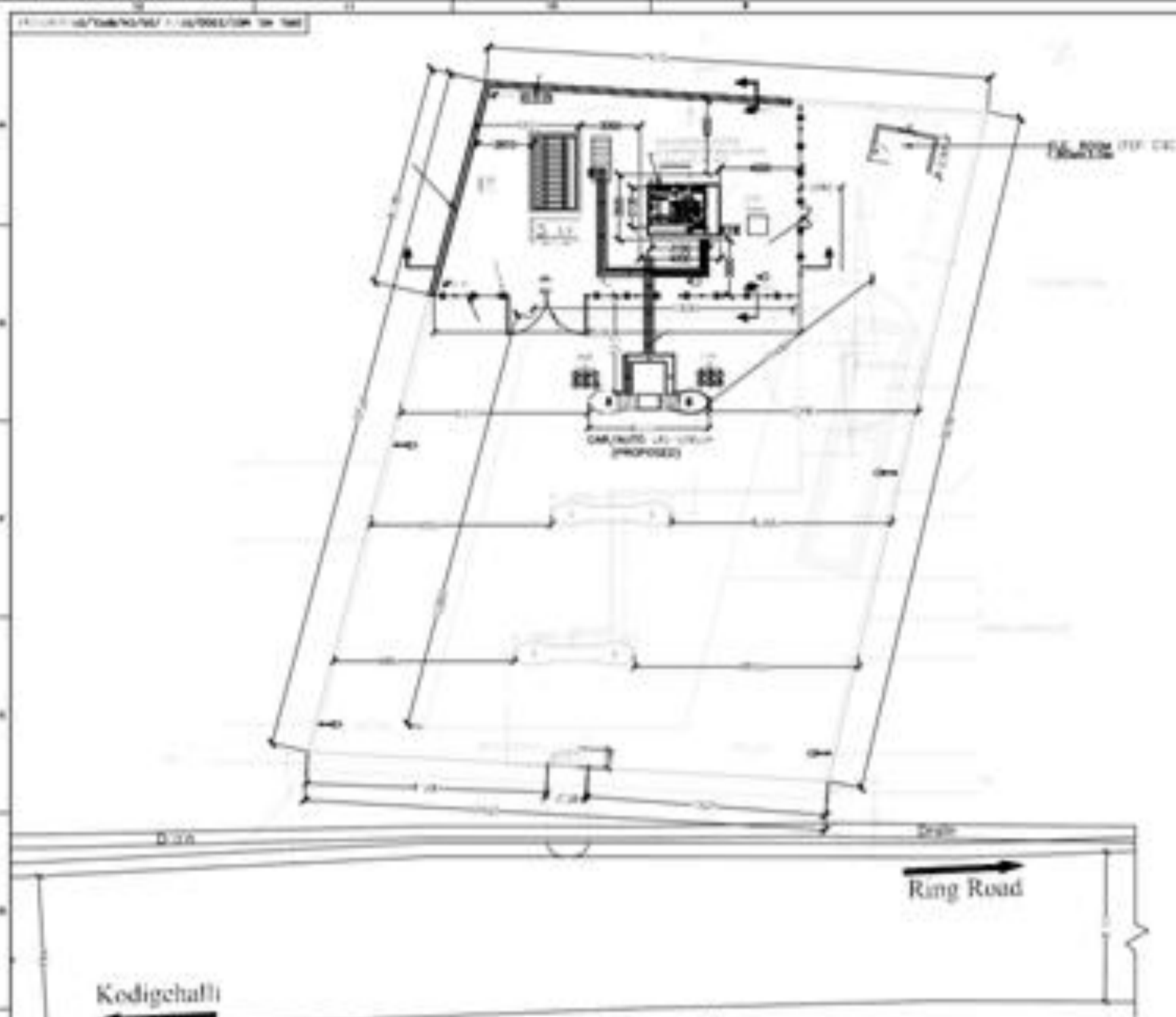

LOCATION PLAN WITH PROPERTIES WITHIN 100 M. RADIUS

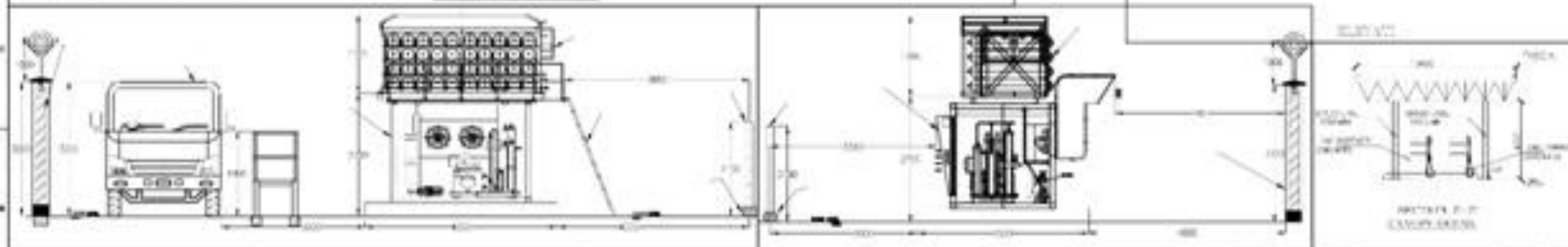

NO.	DESCRIPTION	QTY	REMARKS
1
2
3
4
5
6
7
8
9
10
11
12
13
14
15
16
17
18
19
20

NO.	DESCRIPTION	QTY	REMARKS
1
2
3
4
5
6
7
8
9
10
11
12
13
14
15
16
17
18
19
20

NO.	DESCRIPTION	QTY	REMARKS
1
2
3
4
5
6
7
8
9
10
11
12
13
14
15
16
17
18
19
20

NO.	DESCRIPTION	QTY	REMARKS
1
2
3
4
5
6
7
8
9
10
11
12
13
14
15
16
17
18
19
20

NO.	DESCRIPTION	QTY	REMARKS
1
2
3
4
5
6
7
8
9
10
11
12
13
14
15
16
17
18
19
20

NOTES:

1. ALL DIMENSIONS ARE IN METERS UNLESS OTHERWISE STATED.
2. ALL WORK SHALL BE DONE IN ACCORDANCE WITH THE SPECIFICATIONS AND STANDARDS OF THE RAILWAY BOARD.
3. ALL MATERIALS AND WORKMANSHIP SHALL BE SUBJECT TO INSPECTION AND APPROVAL BY THE RAILWAY BOARD.
4. THE CONTRACTOR SHALL BE RESPONSIBLE FOR OBTAINING ALL NECESSARY APPROVALS AND PERMITS FROM THE RAILWAY BOARD AND THE LOCAL AUTHORITY.
5. THE CONTRACTOR SHALL BE RESPONSIBLE FOR THE PROTECTION AND MAINTENANCE OF ALL EXISTING UTILITIES AND STRUCTURES.
6. THE CONTRACTOR SHALL BE RESPONSIBLE FOR THE PROTECTION AND MAINTENANCE OF ALL EXISTING ROADS AND PATHS.
7. THE CONTRACTOR SHALL BE RESPONSIBLE FOR THE PROTECTION AND MAINTENANCE OF ALL EXISTING BUILDINGS AND STRUCTURES.
8. THE CONTRACTOR SHALL BE RESPONSIBLE FOR THE PROTECTION AND MAINTENANCE OF ALL EXISTING LANDSCAPE AND VEGETATION.
9. THE CONTRACTOR SHALL BE RESPONSIBLE FOR THE PROTECTION AND MAINTENANCE OF ALL EXISTING SERVICES AND UTILITIES.
10. THE CONTRACTOR SHALL BE RESPONSIBLE FOR THE PROTECTION AND MAINTENANCE OF ALL EXISTING STRUCTURES AND UTILITIES.
11. THE CONTRACTOR SHALL BE RESPONSIBLE FOR THE PROTECTION AND MAINTENANCE OF ALL EXISTING SERVICES AND UTILITIES.
12. THE CONTRACTOR SHALL BE RESPONSIBLE FOR THE PROTECTION AND MAINTENANCE OF ALL EXISTING STRUCTURES AND UTILITIES.
13. THE CONTRACTOR SHALL BE RESPONSIBLE FOR THE PROTECTION AND MAINTENANCE OF ALL EXISTING SERVICES AND UTILITIES.
14. THE CONTRACTOR SHALL BE RESPONSIBLE FOR THE PROTECTION AND MAINTENANCE OF ALL EXISTING STRUCTURES AND UTILITIES.
15. THE CONTRACTOR SHALL BE RESPONSIBLE FOR THE PROTECTION AND MAINTENANCE OF ALL EXISTING SERVICES AND UTILITIES.
16. THE CONTRACTOR SHALL BE RESPONSIBLE FOR THE PROTECTION AND MAINTENANCE OF ALL EXISTING STRUCTURES AND UTILITIES.
17. THE CONTRACTOR SHALL BE RESPONSIBLE FOR THE PROTECTION AND MAINTENANCE OF ALL EXISTING SERVICES AND UTILITIES.
18. THE CONTRACTOR SHALL BE RESPONSIBLE FOR THE PROTECTION AND MAINTENANCE OF ALL EXISTING STRUCTURES AND UTILITIES.
19. THE CONTRACTOR SHALL BE RESPONSIBLE FOR THE PROTECTION AND MAINTENANCE OF ALL EXISTING SERVICES AND UTILITIES.
20. THE CONTRACTOR SHALL BE RESPONSIBLE FOR THE PROTECTION AND MAINTENANCE OF ALL EXISTING STRUCTURES AND UTILITIES.

GENERAL NOTES:

1. THE CONTRACTOR SHALL BE RESPONSIBLE FOR OBTAINING ALL NECESSARY APPROVALS AND PERMITS FROM THE RAILWAY BOARD AND THE LOCAL AUTHORITY.
2. THE CONTRACTOR SHALL BE RESPONSIBLE FOR THE PROTECTION AND MAINTENANCE OF ALL EXISTING UTILITIES AND STRUCTURES.
3. THE CONTRACTOR SHALL BE RESPONSIBLE FOR THE PROTECTION AND MAINTENANCE OF ALL EXISTING ROADS AND PATHS.
4. THE CONTRACTOR SHALL BE RESPONSIBLE FOR THE PROTECTION AND MAINTENANCE OF ALL EXISTING BUILDINGS AND STRUCTURES.
5. THE CONTRACTOR SHALL BE RESPONSIBLE FOR THE PROTECTION AND MAINTENANCE OF ALL EXISTING LANDSCAPE AND VEGETATION.
6. THE CONTRACTOR SHALL BE RESPONSIBLE FOR THE PROTECTION AND MAINTENANCE OF ALL EXISTING SERVICES AND UTILITIES.
7. THE CONTRACTOR SHALL BE RESPONSIBLE FOR THE PROTECTION AND MAINTENANCE OF ALL EXISTING STRUCTURES AND UTILITIES.
8. THE CONTRACTOR SHALL BE RESPONSIBLE FOR THE PROTECTION AND MAINTENANCE OF ALL EXISTING SERVICES AND UTILITIES.
9. THE CONTRACTOR SHALL BE RESPONSIBLE FOR THE PROTECTION AND MAINTENANCE OF ALL EXISTING STRUCTURES AND UTILITIES.
10. THE CONTRACTOR SHALL BE RESPONSIBLE FOR THE PROTECTION AND MAINTENANCE OF ALL EXISTING SERVICES AND UTILITIES.
11. THE CONTRACTOR SHALL BE RESPONSIBLE FOR THE PROTECTION AND MAINTENANCE OF ALL EXISTING STRUCTURES AND UTILITIES.
12. THE CONTRACTOR SHALL BE RESPONSIBLE FOR THE PROTECTION AND MAINTENANCE OF ALL EXISTING SERVICES AND UTILITIES.
13. THE CONTRACTOR SHALL BE RESPONSIBLE FOR THE PROTECTION AND MAINTENANCE OF ALL EXISTING STRUCTURES AND UTILITIES.
14. THE CONTRACTOR SHALL BE RESPONSIBLE FOR THE PROTECTION AND MAINTENANCE OF ALL EXISTING SERVICES AND UTILITIES.
15. THE CONTRACTOR SHALL BE RESPONSIBLE FOR THE PROTECTION AND MAINTENANCE OF ALL EXISTING STRUCTURES AND UTILITIES.
16. THE CONTRACTOR SHALL BE RESPONSIBLE FOR THE PROTECTION AND MAINTENANCE OF ALL EXISTING SERVICES AND UTILITIES.
17. THE CONTRACTOR SHALL BE RESPONSIBLE FOR THE PROTECTION AND MAINTENANCE OF ALL EXISTING STRUCTURES AND UTILITIES.
18. THE CONTRACTOR SHALL BE RESPONSIBLE FOR THE PROTECTION AND MAINTENANCE OF ALL EXISTING SERVICES AND UTILITIES.
19. THE CONTRACTOR SHALL BE RESPONSIBLE FOR THE PROTECTION AND MAINTENANCE OF ALL EXISTING STRUCTURES AND UTILITIES.
20. THE CONTRACTOR SHALL BE RESPONSIBLE FOR THE PROTECTION AND MAINTENANCE OF ALL EXISTING SERVICES AND UTILITIES.

APPROVED FOR CCOE APPROVAL

NO.	DESCRIPTION	QTY	REMARKS
1
2
3
4
5
6
7
8
9
10
11
12
13
14
15
16
17
18
19
20

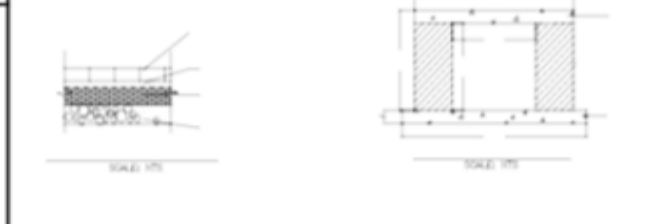
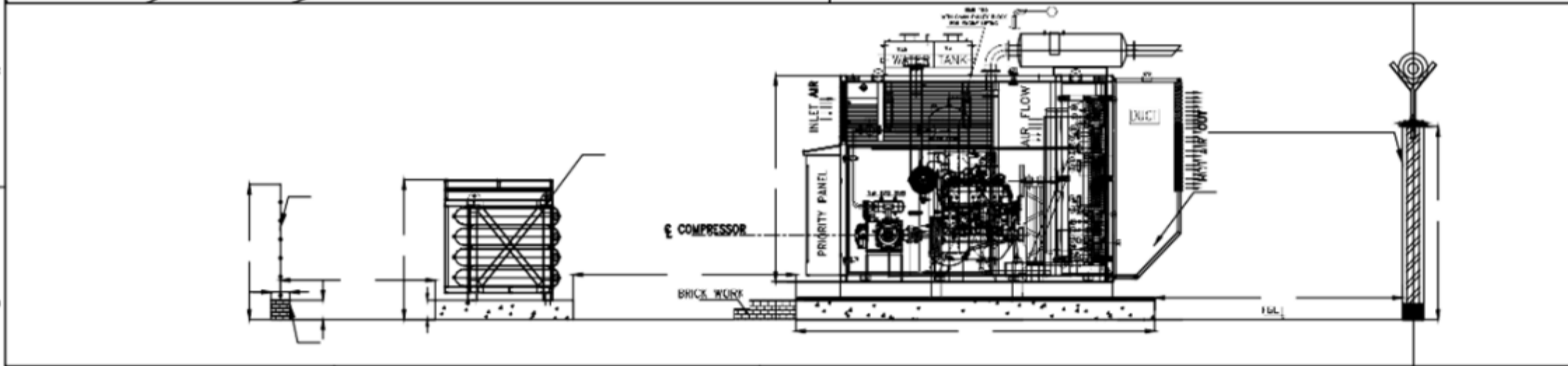
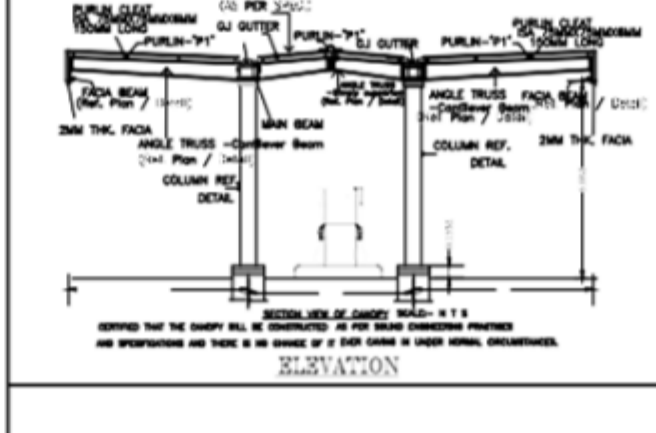
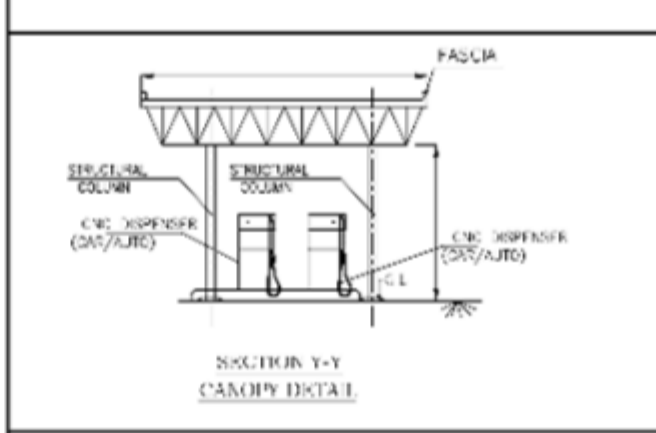
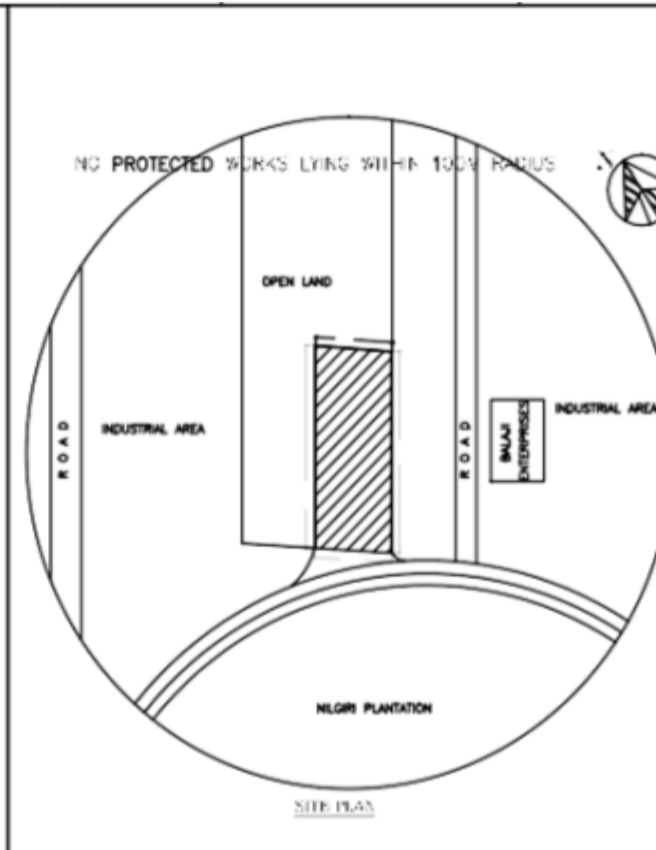
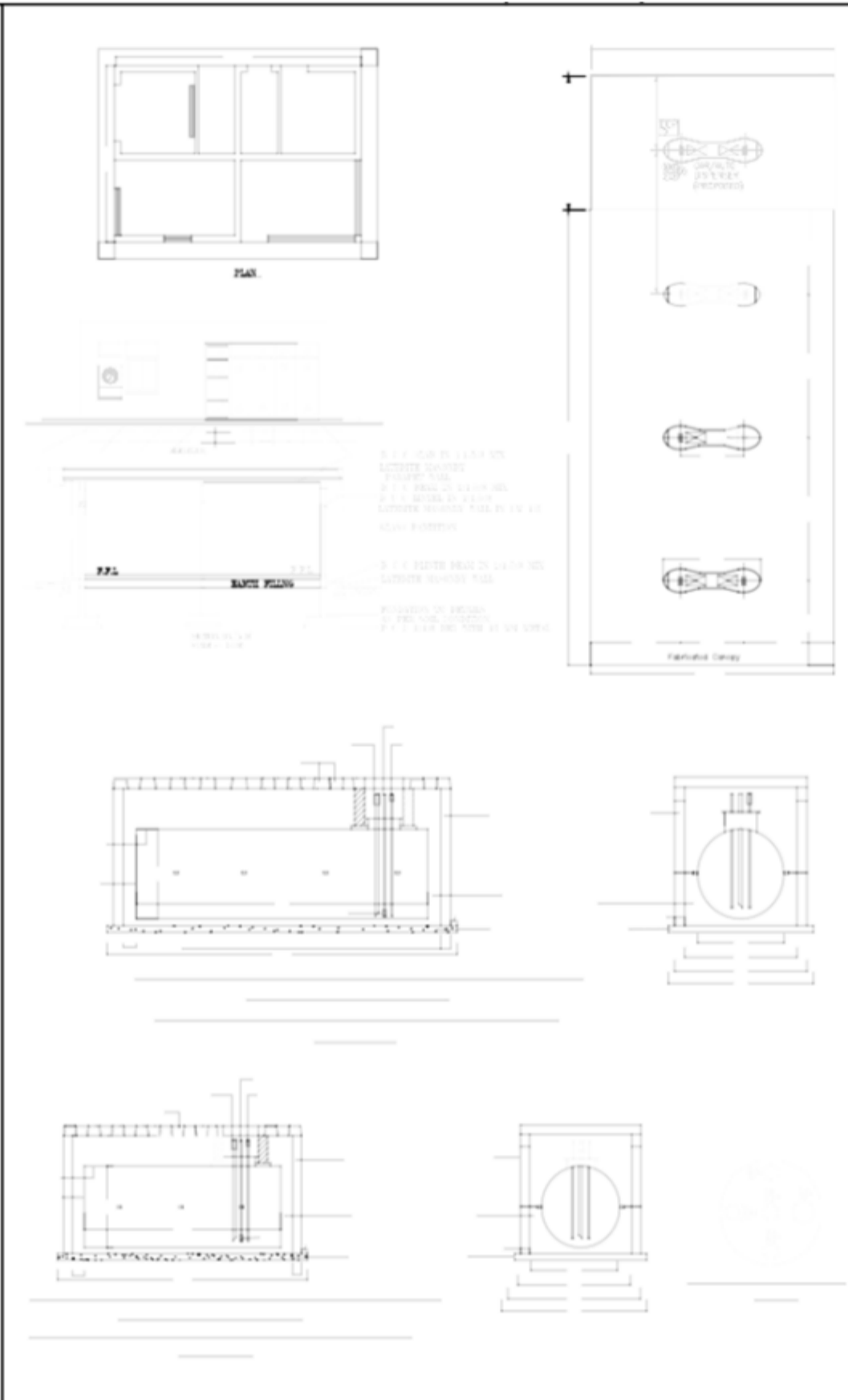
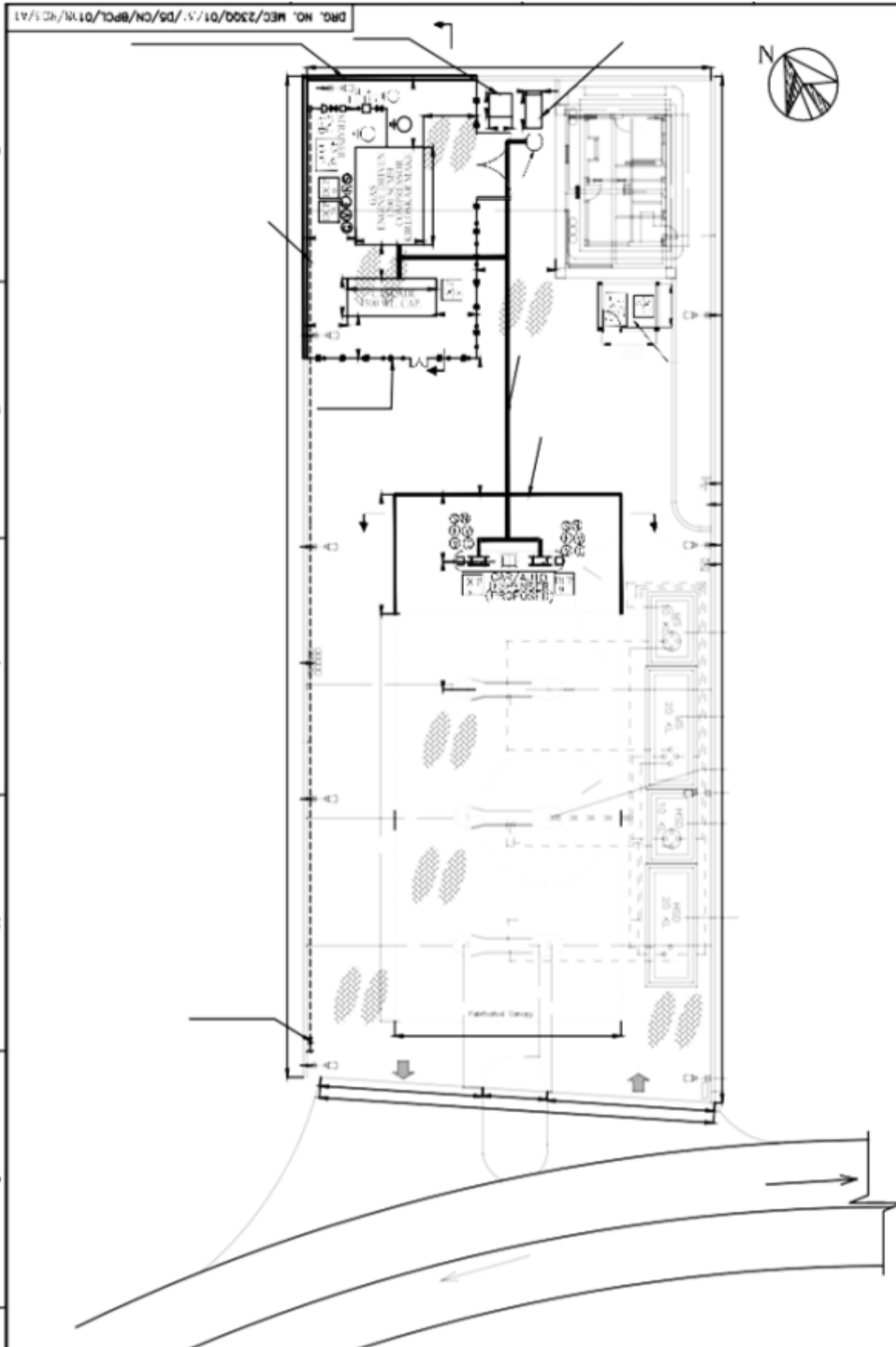

NOTES:-

- ALL DIMENSIONS ARE IN METRE UNLESS OTHERWISE STATED.
- WALLS OF ILLUMINATION HOLES ARE TENTATIVE.
- CNG GAS TUBES SHALL BE LAID IN TRENCH.

CONFIRMATION

- THE LICENSED PREMISES SHALL BE USED ONLY FOR THE PURPOSE AND FACILITIES IT IS LICENSED FOR.
- CNG SHALL BE DISPENSED ONLY INTO THOSE CYLINDERS OF MOTOR VEHICLES WHICH ARE APPROVED BY THE CHIEF CONTROLLER AND HAVE PASSED THE PERIODIC STATUTORY TESTS UNDER THESE RULES CONDUCTED BY A TESTING STATION RECOGNISED BY THE CHIEF CONTROLLER.
- THE CNG CASCADES, COMPRESSORS, PIPING AND OTHER FITTINGS SHALL BE OF A DESIGN SUITABLE FOR CNG IN CONFORMITY TO OSD STD. 179.
- THE STORAGE OF THE CASCADE OF CYLINDERS SHOULD BE MADE IN A WELL-VENTILATED SHED HAVING A LIGHT ROOF OR CANOPY WITH ATLEAST ONE SIDE OPEN, AN AREA OF ATLEAST 1 METER AROUND THE CASCADE SHALL BE PROVIDED WITHIN THE SHED AND THE SAME SHALL BE DEMARCATED EITHER BY RAISED PLATFORM OR BY CURB WALL.
- NO CYLINDER SHALL BE FILLED WITH CNG IN EXCESS OF THE DESIGN WORKING PRESSURE.
- INTER-DISTANCE BETWEEN VARIOUS EQUIPMENTS, STORAGE CASCADES, COMPRESSORS, ETC. INSTALLED IN CNG DISPENSING STATION SHALL BE PROVIDED WITH SAFETY DISTANCES AS PER TABLE I & II OF FORM G OF GAS CYLINDER RULES, 2004.
- THE DISPENSER FOR DISPENSING CNG SHALL BE OF A TYPE APPROVED BY THE CHIEF CONTROLLER.
- THE VEHICLE SHALL HAVE APPROVED TYPE OF CNG KIT FITTED IN ACCORDANCE WITH GUIDELINES OF MINISTRY OF ROAD TRANSPORT AND HIGHWAYS, GOVT. OF INDIA.
- NO MOTOR VEHICLE SHALL BE FUELED WHILE THE ENGINE IS RUNNING AND WHERE THE VEHICLE IS LICENSED FOR THE CONVEYANCE OF MORE THAN SIX PASSENGERS ON THE WHILE ANY PASSENGER REMAINS IN THE VEHICLE.
- WARNING SIGNS WITH THE WORDS "STOP", "GAS" AND "NO OPEN FLAME PERMITTED" SHALL BE DISPLAYED AT DISPENSING STATION AND COMPRESSOR AREA PROMINENTLY.
- ALL ELECTRICAL FITTINGS AND EQUIPMENTS SUCH AS COMPRESSORS, M.O.M.S, SWITCHES, STARTERS, ETC. INSTALLED IN THE PREMISES USED FOR COMPRESSING AND FILLING OF CNG SHALL BE FLAMEPROOF CONSTRUCTION CONFORMING TO IS:2148 OR SUCH OTHER SPECIFICATION AS APPROVED BY THE CODE.
- NO ALTERATIONS OR ADDITIONS SHALL BE CARRIED OUT TO THE PREMISES WITHOUT PRIOR APPROVAL OF THE CODE.
- SMOKING, NAKED LIGHTS, OPEN SOURCE OF FIRE, MOBILE PHONES OR ANY OTHER IMPLEMENTS CAPABLE OF IGNITING FLAMMABLE VAPOUR OR GAS SHALL NOT BE ALLOWED INSIDE THE PREMISES.
- EVERY PERSON MANAGING OR EMPLOYED ON OR IN CONNECTION WITH THE LICENSED PREMISES WILL ABSTAIN FROM ALL ACTS WHICH TEND TO CAUSE FIRE OR EXPLOSION AND WHICH IS NOT REASONABLY NECESSARY AND TO THE BEST OF HIS ABILITY SHALL PREVENT OTHER PERSONS FROM DOING SUCH ACT.
- THE LICENSEE SHALL PROVIDE AT THE FOLLOWING SCALE AT DIFFERENT LOCATIONS.

LOCATION	TYPE OF EXTINGUISHERS
DISPENSING UNIT	1X9 Kg DCP
COMPRESSOR (ON LINE)	1X75 Kg DCP
CNG STORAGE	1X9 Kg DCP

- THE OPERATORS AND ATTENDANTS SHALL BE FULLY CONVERSANT AND TRAINED WITH ALL THE FACETS OF THE DISPENSING ACTIVITIES INCLUDING OPERATIONAL PROCEDURES, MAINTENANCE AND HAZARDS OF CNG AND THE RISK ASSOCIATED WITH THE HANDLING OF THE PRODUCT.
- THE EMERGENCY TELEPHONE NUMBERS OF LOCAL FIRE BRIGADE, POLICE AND THE PRINCIPAL MARKETING COMPANY AND EMERGENCY INSTRUCTIONS SHALL BE CONSPICUOUSLY DISPLAYED IN THE LICENSED PREMISES.
- IF THE LICENSING AUTHORITY CALLS UPON THE HOLDER OF A LICENSE BY A NOTICE IN WRITING TO EXECUTE ANY REPAIRS IN THE LICENSED PREMISES WHICH ARE IN THE OPINION OF SUCH AUTHORITY NECESSARY FOR THE SAFETY OF THE PREMISES, THE HOLDER OF THE LICENSE SHALL EXECUTE THE REPAIRS WITHIN SUCH PERIOD AS MAY BE SPECIFIED IN THE NOTICE.
- FREE ACCESS TO THE LICENSED PREMISES SHALL BE GIVEN AT ALL REASONABLE TIME TO ANY OF THE OFFICERS LISTED IN RULE 71 AND EVERY FACILITY SHALL BE AFFORDED TO SUCH OFFICER FOR ASCERTAINING THAT THE RULES AND THE CONDITIONS OF THIS LICENSE ARE DULY OBSERVED.
- ANY ACCIDENT, FIRE, EXPLOSION OR UNLAWFUL INCIDENT OCCURRED WITHIN THE LICENSED PREMISES SHALL BE IMMEDIATELY REPORTED TO THE CHIEF CONTROLLER, CONTROLLER, DISTRICT MAGISTRATE AND THE OFFICER - IN - CHARGE OF THE NEAREST POLICE STATION BY QUICKEST MODE OF COMMUNICATION.

CERTIFICATE

- CERTIFIED THAT ALL THE CLEARANCE / APPROVALS FROM MOP & OTHER RELEVANT GOVT. DEPARTMENTS HAVE ALREADY BEEN OBTAINED.
- IT IS CERTIFIED THAT ALL THE IRC GUIDELINES ARE MET.
- IT IS CERTIFIED THAT TO BEST OF OUR KNOWLEDGE THERE IS NO COURT CASE PENDING IN ANY COURT OF LAW AGAINST THESE PREMISES AND DEPARTMENT.
- IT IS CERTIFIED THAT THIS IS NEW CNG STATION IN EXISTING RETAIL OUTLET.
- IT IS CERTIFIED THAT ALL THESE FACILITIES HAVE BEEN PROVIDED ARE EXACTLY AS PER THE DRAWING.
- IT IS CERTIFIED THAT NO HIGH TENSION LINE / ELECTRIC LINE ARE PASSING OVER THE PREMISES.

PLOT INFORMATION:-

LOCATION : SRIGANDHADA KAWALI, SUNKADAKATTE, MAGADI MAIN ROAD, BANGALORE.

NAME OF CITY : BANGALORE.

NEAREST POLICE STATION : KAMAKSHIPALYA

NEAREST RLY. STATION : BANGALORE JN.

DISTANCE FROM RLY. STATION : 8.0 Km (APPROX.)

STATE PIN CODE : KARNATAKA 560091

CNG STATION PLOT AREA : 1672.83 SQ.M.

OFFICE BUILDING AREA : 56.64 SQ.M.

PROPOSED CANOPY AREA : 95.5 SQ.M.

REFERENCES:-

- FOR DETAILS OF COMPRESSOR, REFER DWG NO. P/SC/KA/14/2866/022/1/G/2
- FOR PAID OF COMPRESSOR, REFER DWG NO. P/SC/021/9/PI/D, SHEET 1, 2, 3 & 4.
- FOR DETAILS OF CASCADE, REFER DWG NO. R-CAS-CAD-207-75-40-3-GAL
- FOR PAID OF CASCADE, REFER DWG NO. R-CAS-CAD-261-75-40-3-GAL

NOTES

- ALL DIMENSIONS ARE IN MM.
- CNG DISPENSING IS CONTROLLED BY 3 CHARGE CASCADE VIA CNG COMPRESSOR CASCADE VIA CNG COMPRESSOR BY GAS TUBES.
- THE PROPOSED CNG FACILITIES ARE DESIGNED IN ACCORDANCE WITH THE FOLLOWING CODE AND GUIDELINES:
 - NZS 5425 - 1994/OSD - 79
 - PETROLEUM RULES - 2004.
 - GAS CYLINDER RULES - 2004. (GOVT. OF INDIA)
 - GUIDE LINES OF CHIEF CONTROLLER OF EXPLOSIVES MANGUR.
- FIRE SAFETY EQUIPMENT FOR CNG FACILITIES SHALL BE PROVIDED.
- FIRE SAFETY AND TRAFFIC SIGNS SHALL BE INSTALLED.

REVISIONS

NO.	DESCRIPTION	DATE
1
2
3

EQUIPMENT SCHEDULE

S.NO.	EQUIPMENT	NO.	SERVICE	BLOCK SIZE L x W x H (IN M.M)	CAPACITY
1	COMPRESSOR-GAS ENGINE DRIVEN	1	C.A.G.	5.8x4.2x3.8	1200 SCMH
2	STATIONARY CASCADE	1	C.A.G.	5.5x2.3x1.8	4500 LTR. WATER
3	CAT/AUTO DISPENSER	2	C.A.G.	1.15x0.5x1.90	15.0 C/M3 FLOW

SAFETY FEATURES:-

- 9 KG DCP TYPE FIRE EXTINGUISHER NEAR STATIONARY CASCADE, ON LINE COMPRESSOR & CNG DISPENSER.
- 75 KG DCP TYPE FIRE EXTINGUISHER NEAR ON-LINE COMPRESSOR.
- CO2 FLOODING SYSTEM OUTSIDE COMPRESSOR ENCLOSURE.

GAL GAS LIMITED

BHARAL PHENOLIM (P) LTD. (P) LTD. BANGALORE

LC NO: P/SC/KA/14/2866(162115)

NO.	DATE	AUTH.	DESCRIPTION	BY	VERIFY	SECTION	SCALE
3	08.02.2016		AS PER CODE COMMENTS DTD 17.05.2016				
2	08.02.2016		AS PER CODE COMMENTS				
1	27.01.2016		ISSUE FOR CODE APPROVAL				
0	30.11.2015		ISSUE FOR PLANNING				

PROJECT NO: D/SC/021/9/PI/D/EXPLO/2007.

DATE: 08.02.2016

ONLINE CNG STATION FOR COE APPROVAL

NO.	DATE	AUTH.	DESCRIPTION	BY	VERIFY	SECTION	SCALE
1

CITY GAS DISTRIBUTION NETWORK

DATE: 08.02.2016

SCALE: AS ABOVE

PROJECT NO: D/SC/021/9/PI/D/EXPLO/2007/1